

# DRAFT – FEBRUARY 2019

New Plymouth District Council, South Taranaki  
District Council and Stratford District Council

## Code of Practice for Land Development and Subdivision Infrastructure (Version 3)



Te Kaunihera-ā-Rohe o Ngāmotu  
**New Plymouth  
District Council**



**STRATFORD  
DISTRICT COUNCIL**



**REAL ENERGY**  
South Taranaki  
District Council

DRAFT FOR CONSULTATION - DO NOT PRINT

*This document sets out the minimum standards of technical performance and quality for the subdivision and development of land and infrastructure required by, or undertaken by New Plymouth District Council (NPDC), South Taranaki District Council (STDC) and Stratford District Council (SDC) and provides guidelines as to how these standards may be met. This standard supersedes NPDC's Code of Practice for Infrastructure 2009 and NPDC's 1997 Code of Practice.*

*The Code is based on NZS 4404:2010 Land Development and Subdivision Infrastructure. This document contains text from NZS 4404:2010 with local amendments adopted by NPDC, STDC and SDC incorporated into the text. Local amendments are shown in italics.*

*Content from NZS 4404:2010 Land development and subdivision infrastructure used in this document remains the copyright of the Crown and is administered by the New Zealand Standards Executive, reproduced with permission from Standards New Zealand, on behalf of the New Zealand Standards Executive, under copyright licence LN001243. NPDC, STDC and SDC are responsible for the accuracy of this document and its requirements.*

DRAFT FOR CONSULTATION

## Contents

Referenced Documents .....	12
Related Documents .....	17
Latest Revisions .....	19
Review of Standards .....	19
Foreword .....	20
Outcome Statement .....	21

## Sections

1	GENERAL REQUIREMENTS AND PROCEDURES .....	23
1.1	Scope .....	23
1.2	Interpretation .....	23
1.2.1	General .....	23
1.2.2	Definitions .....	24
1.2.3	Abbreviations .....	27
1.3	Context .....	29
1.3.1	Resource Management Act .....	30
1.3.2	Heritage New Zealand Pouhere Taonga Act .....	30
1.3.3	Building Act .....	31
1.3.4	Other legislation .....	31
1.4	Low impact design .....	31
1.5	Climate change .....	31
1.6	Urban design protocol .....	32
1.7	Requirements for design and construction .....	32
1.7.1	Investigation and design .....	32
1.7.2	Construction .....	32
1.8	Approval of design and construction .....	33
1.8.1	Documents to be submitted for design approval .....	33
1.8.2	Drawings .....	33
1.8.3	Design basis for documents submitted for approval .....	35
1.8.4	Approval of design .....	35
1.8.5	Notification of contracts and phases of construction .....	35
1.8.6	Supervision of construction .....	36
1.8.7	Connecting to existing services .....	36
1.8.8	Testing .....	37
1.8.9	Maintenance .....	37
1.8.10	Completion documentation .....	37
1.8.11	Approval of uncompleted work .....	37
1.8.12	Defects Liability Period .....	37
1.9	Bonds and charges .....	38
1.9.1	Uncompleted works .....	38
1.9.2	Defects Liability Bond .....	38
1.10	Fees and Charges .....	39

2	EARTHWORKS AND GEOTECHNICAL REQUIREMENTS .....	44
2.1	Scope .....	44
2.2	General.....	44
2.2.1	Objective .....	44
2.2.2	Referenced documents .....	44
2.2.3	Territorial authorities' requirements.....	45
2.2.4	Geotechnical requirements.....	45
2.3	Design .....	45
2.3.1	Design factors .....	45
2.3.2	Preliminary site evaluation.....	46
2.3.3	Landform selection .....	47
2.3.4	Stability criteria.....	48
2.3.5	Special soil types .....	48
2.3.6	Compaction standards for fill material.....	49
2.3.7	Erosion, sediment, and dust control .....	49
2.3.8	Seismic considerations.....	50
2.4	Approval of proposed works.....	50
2.5	Construction .....	50
2.6	Final documentation.....	50
2.6.1	Geotechnical completion report.....	50
2.6.2	As-built drawings for earthworks and subsoil drains.....	51
3	ROADS .....	54
3.1	Scope .....	54
3.2	General.....	54
3.2.1	Objective .....	54
3.2.2	Related Standards and guidelines .....	54
3.2.3	Road purpose .....	54
3.2.4	Deleted (Place and link context).....	55
3.2.5	Network connectivity.....	55
3.2.6	Design and access statement .....	55
3.2.7	Road safety audit.....	56
3.3	Design .....	56
3.3.1	Design requirements.....	56
3.3.2	Road geometric design.....	58
3.3.3	Pavement structural design .....	75
3.3.4	Safety barrier provisions .....	77
3.3.5	Target operating speed .....	77
3.3.6	Parking, passing, and loading .....	78
3.3.7	Intersection and alignment design.....	78
3.3.8	No-exit roads.....	78
3.3.9	Bus stops .....	79
3.3.10	Special road and footpath provisions near places of assembly....	79
3.3.11	Footpaths, accessways, cycle paths, and berms.....	79
3.3.12	Traffic signs, marking, and road furniture.....	81
3.3.13	Trees and landscaping .....	82
3.3.14	Road lighting .....	82
3.3.15	Bridges and culverts .....	83



	3.3.16 Private ways, private roads, and other private accesses.....	88
	3.3.17 Crossings .....	92
	3.3.18 Fencing .....	103
	3.3.19 Road run-off.....	103
3.4	Construction .....	116
	3.4.1 Introduction .....	116
	3.4.2 Materials for flexible pavements.....	116
	3.4.3 Road surfacing.....	116
	3.4.4 Road surfacing materials.....	118
	3.4.5 Subgrade checking.....	119
	3.4.6 Spreading and compaction of metal course aggregates .....	119
	3.4.7 Sub-base.....	119
	3.4.8 Basecourse.....	119
	3.4.9 Maintenance of basecourse .....	120
	3.4.10 Basecourse preparation for surfacing .....	120
	3.4.11 Deflection testing prior to surfacing.....	120
	3.4.12 Surfacing specification.....	120
	3.4.13 Bitumen application rate .....	120
	3.4.14 Footpaths and cycle paths.....	121
	3.4.15 Kerb and channel.....	121
	3.4.16 Berms and landscaping.....	122
	3.4.17 Surface finish and tolerances on kerbs, paths, and accessways.....	122
	3.4.18 Progress inspections .....	122
	3.4.19 Installation of traffic services, road furniture, benchmarks.....	123
	3.4.20 As-built and completion documentation .....	123
4	STORMWATER.....	124
	4.1 Scope .....	124
	4.2 General .....	124
	4.2.1 Objectives .....	124
	4.2.2 Legislation and guidance manuals .....	124
	4.2.3 Territorial authorities' requirements.....	124
	4.2.4 Catchment management planning .....	125
	4.2.5 Effects of land use on receiving waters.....	125
	4.2.6 System components .....	125
	4.2.7 Catchments and off-site effects.....	126
	4.2.8 Water quality .....	126
	4.2.9 Climate change.....	126
	4.3 Design .....	127
	4.3.1 Design life .....	127
	4.3.2 Structure plan.....	127
	4.3.3 Future development.....	127
	4.3.4 System design .....	127
	4.3.5 Design criteria.....	128
	4.3.6 Stormwater pumping.....	132
	4.3.7 Low impact design .....	132
	4.3.8 Natural and constructed waterways .....	136
	4.3.9 Pipelines and culverts.....	137
	4.3.10 Manholes .....	139

4.4	Approval of proposed infrastructure.....	143
4.4.1	Approval process.....	143
4.4.2	Information to be provided.....	143
4.5	Construction.....	144
4.5.1	Pipeline construction.....	144
4.5.2	Trenching.....	144
4.5.3	Reinstatement.....	144
4.5.4	Inspection and acceptance.....	144
4.6	Catchment Management Plan – Sample Contents.....	144
5	WASTEWATER.....	146
5.1	Scope.....	146
5.2	General.....	146
5.2.1	Objectives.....	146
5.2.2	Referenced documents and relevant guidelines.....	146
5.3	Design.....	146
5.3.1	Design life.....	146
5.3.2	Structure plan.....	147
5.3.3	Future development.....	147
5.3.4	System design.....	147
5.3.5	Design criteria.....	147
5.3.6	Structural design.....	150
5.3.7	System layout.....	152
5.3.8	Maintenance structures.....	154
5.3.9	Venting.....	159
5.3.10	Connections.....	160
5.3.11	Pumping stations and pressure mains.....	163
5.3.12	Pressure sewers and vacuum sewers.....	167
5.3.13	On-site wastewater treatment and disposal.....	168
5.4	Approval of proposed infrastructure.....	168
5.4.1	Approval process.....	168
5.4.2	Information to be provided.....	168
5.5	Construction.....	168
5.5.1	Pipeline construction.....	168
5.5.2	Trenching.....	168
5.5.3	Reinstatement.....	168
5.5.4	Inspection and acceptance.....	168
5.5.5	Leakage testing of gravity pipelines.....	169
5.5.6	Leakage testing of pressurised sewers.....	170
6	WATER SUPPLY.....	171
6.1	Scope.....	171
6.2	General requirements.....	171
6.2.1	Objectives.....	171
6.2.2	Referenced documents and relevant guidelines.....	172
6.3	Design.....	172
6.3.1	Design life.....	172

6.3.2	Structure plan.....	172
6.3.3	Future development.....	172
6.3.4	System design.....	172
6.3.5	Design criteria.....	172
6.3.6	Water quality.....	176
6.3.7	Flow velocities.....	176
6.3.8	System layout.....	177
6.3.9	Clearances.....	182
6.3.10	Pipe selection.....	183
6.3.11	Fire flow.....	184
6.3.12	Structural design.....	185
6.3.13	Reservoirs and pumping stations.....	188
6.3.14	Valves.....	191
6.3.15	Hydrants.....	198
6.3.16	Connections.....	200
6.3.17	Termination points.....	208
6.4	Approval of proposed infrastructure.....	209
6.4.1	Approval process.....	209
6.4.2	Information to be provided.....	209
6.5	Construction.....	210
6.5.1	Excavation.....	210
6.5.2	Embedment.....	210
6.5.3	Backfilling and reinstatement.....	210
6.5.4	Pressure testing of water mains.....	211
6.5.5	Disinfection of water mains.....	211
6.5.6	Discharge of testing water.....	211
6.5.7	Water sampling.....	211
7	LANDSCAPE.....	212
7.1	Scope.....	212
7.2	General.....	212
7.2.1	Approval.....	212
7.2.2	Environmentally-responsive design.....	212
7.2.3	Reserves and land protection covenants.....	212
7.2.4	Ecological, functional, and aesthetic opportunities.....	212
7.2.5	Landscape and planting opportunities.....	213
7.3	Design.....	213
7.3.1	Location.....	213
7.3.2	Reserve location and layout.....	214
7.3.3	Existing vegetation and trees.....	214
7.3.4	New trees and road geometry.....	214
7.3.5	Planted grass areas, berms, swales, or rain gardens.....	214
7.3.6	Species selection.....	214
7.3.7	Quality control.....	215
7.3.8	Landscaping structures.....	215
7.3.9	Fencing of reserves.....	216
7.3.10	Planting period and irrigation.....	216
7.4	Construction and maintenance.....	216

7.4.1	Introduction .....	216
7.4.2	Soil and fertility .....	216
7.4.3	Weeds and litter control .....	216
7.4.4	Planting grass areas .....	217
7.4.5	Mulch .....	217
7.4.6	Specimen tree planting .....	218
7.4.7	General amenity planting .....	218
7.4.8	Revegetation planting and existing vegetation .....	219
7.4.9	Swales, rain gardens, wetlands, and riparian margins planting ..	219
7.4.10	Pruning .....	219
7.4.11	Maintenance .....	219
8	NETWORK UTILITY SERVICES .....	221
8.1	Scope .....	221
8.2	General .....	221
8.2.1	Legislation .....	221
8.2.2	Definitions .....	221
8.2.3	Context .....	221
8.3	Design .....	222
8.3.1	Plans .....	222
8.3.2	Utilities above ground .....	222
8.4	Construction .....	222
8.4.1	Underground cabling .....	222
8.4.2	Materials .....	223
8.4.3	Conversion to underground on existing roads .....	223
8.4.4	Commercial and industrial subdivisions .....	223
8.4.5	Location of services .....	223
8.4.6	Trenches .....	223

## Appendices

Appendix A – Acceptable Pipe and Fitting Materials .....	224
Appendix B – Standard Construction Drawings .....	241
Appendix C – Field Testing of Pipelines .....	257
Appendix D1 – Water Supply Disinfection Specification for new pipelines .....	271
Appendix D2 - Water Supply Disinfection Procedure for Cut-In To Existing Pipelines ..	273
Appendix E – Water Mains in Private Land .....	276

## Tables

Table 3.1 – Deleted (Land use and area type matrix describing typical place & transport context) .....	55
Table 3.1a: Widening on horizontal curves for Primary, Collector and Sub-collector roads (50km/h design speeds) .....	61
Table 3.1b: Widening on horizontal curves for Local roads (less than 50km/h design speeds) .....	61
Table 3.2 - Road design standards .....	62

Table 3.2a – Pavement design parameters.....	75
Table 3.3 - Surfacing standards.....	117
Table 3.4 - Benkelman beam standards.....	120
Table 4.1 - Minimum AEP for design storms.....	129
Table 4.2 - Manning’s “n”.....	131
Table 4.3 – Loss coefficients for bends.....	132
Table 4.4 - Spacing of bulkheads for pipes on steep grades.....	139
Table 5.1 - Commercial and industrial flows.....	148
Table 5.2 – Deleted (Guide to roughness coefficients for gravity sewer lines).....	148
Table 5.3 - Minimum pipe sizes for wastewater reticulation and property connections.....	148
Table 5.4 - Minimum grades for wastewater pipes.....	149
Table 5.5 - Minimum grades for property connections and permanent ends.....	149
Table 5.6 - Clearances between wastewater pipes and other underground services.....	154
Table 5.7 - Acceptable MH, MS, and TMS options for waste water reticulation.....	155
Table 5.8 - Maximum allowable deflections through MHs.....	157
Table 5.9 - Minimum internal fall through MH joining pipes of same diameter.....	157
Table 6.2 - Empirical guide for principal main sizing.....	174
Table 6.3 - Empirical guide for sizing rider mains.....	175
Table 6.3a - Service pressure at point of supply.....	176
Table 6.4 - Clearances between water mains and underground services.....	182
Table 6.5 - Minimum clearance from structures.....	183
Table 6.5a - Minimum cover.....	187
Table 6.6 – Deleted (Valve spacing criteria).....	194
Table 6.7 - Minimum scour size.....	197

## Figures

Figure 3.0a - Typical rural road cross section detail.....	59
Figure 3.0b – Cross section of urban berm indicating road infrastructure, services and utilities.....	60
Figure 3.0c – Common services trench.....	60
Figure 3.1 - Parameter relationship.....	76
Figure 3.2 - Influence of road geometry on speed.....	77
Figure 3.2a - Safety fence.....	80
Figure 3.2b - Flume in ground.....	84
Figure 3.2c – Flume out of ground.....	85
Figure 3.2d - Energy dissipater.....	86
Figure 3.2e - Pipe outlet protection.....	87
Figure 3.3 - Circular turning head: dimensions of no-exit road turning areas.....	90
Figure 3.3a –Y Turning: dimensions of no-exit road turning areas.....	91

Figure 3.3b - Turning areas for private no-exit roads .....	92
Figure 3.4 – Mobility crossing .....	94
Figure 3.4a - Standard urban vehicle crossing .....	95
Figure 3.4b - Urban slot vehicle crossing .....	96
Figure 3.4c - Urban plate vehicle crossing .....	97
Figure 3.4e - Urban vehicle crossings for double garages .....	99
Figure 3.4f - Maximum breakover angles for vehicular access to property .....	100
Figure 3.4g - Rural vehicle crossings .....	102
Figure 3.5 - Subsoil drains .....	104
Figure 3.6 – Swale cross section – urban design (for reticulated systems only) .....	105
Figure 3.7 - Kerbs and dished channels .....	106
Figure 3.8 - Typical sump to driveway or right of way .....	108
Figure 3.9 - Flat channel or yard sump .....	109
Figure 3.10 - Mountable kerb sump and grate detail .....	110
Figure 3.11 - Add-on to back-entry sump for hillside situations .....	111
Figure 3.12 - An alternative sump for hillside situations .....	112
Figure 3.13 - Special entry to double sump in hillside channel .....	113
Figure 3.14 - Double back-entry sump for road low points .....	114
Figure 4.1 - Discharge to a kerb connection .....	142
Figure 4.2 - Discharge to a sump .....	142
Figure 5.1 - Multiple MSs between MH and 'last' MH/TMS .....	156
Figure 5.2 - Multiple MSs between consecutive MHs .....	156
Figure 5.3 - Point of discharge location - single dwelling with street frontage (NPDC only) .....	161
Figure 5.4 - Point of discharge location - sewer on private land .....	161
Figure 5.4a - Typical layout at point of discharge (STDC only) .....	162
Figure 5.5 - Boundary kit detail .....	164
Figure 5.6 - Point of discharge locations - private pump stations (sections) .....	164
Figure 5.7 - Point of discharge locations - private pump stations (plan) .....	165
Figure 5.8 - Pipeline support .....	169
Figure 6.0 - Service markings .....	181
Figure 6.0a - Fire and service connection details .....	185
Figure 6.0b - Valve installation details .....	192
Figure 6.0c - Valve extension spindle .....	193
Figure 6.1 - Branch valve adjacent to main .....	195
Figure 6.3 - Secure connection .....	195
Figure 6.3a - Hydrant installation .....	199
Figure 6.3b - Standard water boundary box and point of supply (NPDC only) .....	202
Figure 6.3c - Point of supply for commercial connections (NPDC only) .....	203

Figure 6.3d - Point of supply for industrial/commercial service and fire connections  
(NPDC only)..... 204

Figure 6.3e - Backflow prevention on 150mm dia water main ..... 206

Figure 6.3f - 20mm NB backflow preventer (NPDC only)..... 207

Figure 6.4 - Elimination of termination points ..... 208

Figure 6.5 - Looped and link principal mains ..... 208

## **Schedules**

---

Schedule 1A Design Certificate – Land Development/Subdivision..... 40

Schedule 1B Contractor’s Certificate Upon Completion of Land  
Development/Subdivision ..... 41

Schedule 1C Certification Upon Completion of Land Development/Subdivision ..... 42

Schedule 1D As-Built Plans ..... 43

Schedule 2A Statement of Professional Opinion on Suitability of Land for Building  
Construction ..... 52

DRAFT FOR CONSULTATION

## REFERENCED DOCUMENTS

Reference is made in this document to the following:

### NEW ZEALAND STANDARDS

NZS 1170:- - -	Structural design actions
Part 5:2004	Earthquake actions – New Zealand
Part 5 Supp 1:2004	Earthquake actions – New Zealand – Commentary
NZS 3109:1997	Concrete construction
NZS 3114:1987	Specification for concrete surface finishes
NZS 3116:2002	Concrete segmental and flagstone paving
NZS 3604:XXXX	Timber-framed buildings (in preparation)
NZS 4402:- - -	Methods of testing soils for civil engineering purposes
Part 6:1986	Soil strength tests
NZS 4405:1986	Helical lock-seam corrugated steel pipes
NZS 4406:1986	Helical lock-seam corrugated steel pipes – Design and installation
NZS 4431:1989	Code of practice for earth fill for residential development
NZS 4442:1988	Welded steel pipes and fittings for water, sewage and medium pressure gas
NZS 5828:2004	Playground equipment and surfacing
NZS/AS 1657:1992	Fixed platforms, walkways, stairways and ladders. Design, construction and installation
NZS/BS 750:1984	Specification for underground fire hydrants and surface box frames and covers
SNZ HB 5828.1:2006	General playground equipment and surfacing handbook
SNZ PAS 4509:2008	New Zealand Fire Service firefighting water supplies code of practice

### JOINT AUSTRALIAN/NEW ZEALAND STANDARDS

AS/NZS 1158:- - -	Road lighting
Part 0:2005	Introduction
Part 1.1:2005	Vehicular traffic (category V) lighting – Performance and design requirements
Part 1.3:1997	Vehicular traffic (category V) lighting – Guide to design, installation, operation and maintenance
Part 3.1:2005	Pedestrian area (category P) lighting – Performance and design requirements
AS/NZS 1254:2010	PVC-U pipes and fittings for stormwater and surface water applications
AS/NZS 1260:2009	PVC-U pipes and fittings for drain, waste and vent application
AS/NZS 1477:2006	PVC pipes and fittings for pressure applications
AS/NZS 1546:- - -	On-site domestic wastewater treatment units
Part 1:2008	Septic tanks
AS/NZS 1547:XXXX	On-site domestic wastewater management (in preparation)
AS/NZS 2032:2006	Installation of PVC pipe systems
AS/NZS 2033:2008	Installation of polyethylene pipe systems
AS/NZS 2041:1998	Buried corrugated metal structures
AS/NZS 2280:2004	Ductile iron pipes and fittings



AS/NZS 2566:- - - -	Buried flexible pipelines
Part 1:1998	Structural design
Part 1 Supp 1:1998	Structural design – Commentary
Part 2:2002	Installation
AS/NZS 2890:----	Parking facilities
Part 1:2004	Off street car parking
AS/NZS 3500:- - - -	Plumbing and drainage
Part 1:2003	Water services
AS/NZS 3518:2004	Acrylonitrile butadiene styrene (ABS) compounds, pipes and fittings for pressure applications
AS/NZS 3690:2009	Installation of ABS pipe systems
AS/NZS 3725:2007	Design for installation of buried concrete pipes
AS/NZS 3845:1999	Road safety barrier systems
AS/NZS 3879:2006	Solvent cements and priming fluids for PVC (PVC-U and PVC-M) and ABS pipes and fittings
AS/NZS 4020:2005	Testing of products for use in contact with drinking water
AS/NZS 4058:2007	Precast concrete pipes (pressure and non-pressure)
AS/NZS 4087:2011	Metallic flanges for water works purposes
AS/NZS 4129:2008	Fittings for polyethylene (PE) pipes for pressure applications
AS/NZS 4130:2009	Polyethylene (PE) pipes for pressure applications
AS/NZS 4131:2010	Polyethylene (PE) compounds for pressure pipes and fittings
AS/NZS 4158:2003	Thermal-bonded polymeric coatings on valves and fittings for water industry purposes
AS/NZS 4441:2008	Oriented PVC (PVC-O) pipes for pressure applications
AS/NZS 4765:2007	Modified PVC (PVC-M) pipes for pressure applications
AS/NZS 4793:2009	Mechanical tapping bands for waterworks purposes
AS/NZS 4998:2009	Bolted unrestrained mechanical couplings for waterworks purposes
AS/NZS 5065:2005	Polyethylene and polypropylene pipes and fittings for drainage and sewerage applications

## AUSTRALIAN STANDARDS

AS 1579:2001	Arc-welded steel pipes and fittings for water and waste-water
AS 1741:1991	Vitrified clay pipes and fittings with flexible joints – Sewer quality
AS 1906:- - - -	Retroreflective materials and devices for road traffic control purposes
Part 3:1992	Raised pavement markers (retroreflective and non-retroreflective)
AS 2200:2006	Design charts for water supply and sewerage
AS 2638:- - - -	Gate valves for waterworks purposes
Part 2:2006	Resilient seated
AS 2700:1996	Colour Standards for general purposes
AS 2870:1996	Residential slabs and footings – Construction
AS 2890:- - - -	Parking facilities
Part 5:1993	On-street parking
AS 3571:- - - -	Plastics piping systems – Glass-reinforced thermoplastics (GRP) systems based on unsaturated polyester (UP) resin
Part 1:2009	Pressure and non-pressure drainage and sewerage

Part 2:2009	Pressure and non-pressure water supply
AS 3681:2008	Application of polyethylene sleeving for ductile iron piping
AS 3996:2006	Access covers and grates

## BRITISH STANDARDS

BS EN 295:- - - -	Vitrified clay pipes and fittings and pipe joints for drains and sewers
Part 1:1991	Requirements
Part 2:1991	Quality control and sampling
Part 3:1991	Test methods
Part 4:1995	Requirements for special fittings, adaptors and compatible accessories
Part 6:1996	Requirements for vitrified clay manholes
Part 7:1996	Requirements for vitrified clay pipes and joints for pipe jacking
Part 10:2005	Performance requirements
BS EN 805:2000	Water supply – Requirements for systems and components outside buildings

## OTHER PUBLICATIONS

### GENERAL

Ministry for the Environment. *New Zealand urban design protocol*. Wellington: Ministry for the Environment, 2005.

### EARTHWORKS AND GEOTECHNICAL REQUIREMENTS

BRANZ. *BRANZ Study Report 004, Assessment of slope stability at building sites*. BRANZ and Worley Consultants Ltd, 1987.

Cook, D, Pickens, G A, and MacDonald, G. 'The role of peer review', Report by Crawford S A. *NZ Geomechanics News* (Dec 1995).

Crawford, S A, and Millar, P J. 'The design of permanent slopes for residential building development', EQC Research Project 95/183, *NZ Geomechanics News* (June 1998).

New Zealand Geotechnical Society Inc. *Field description of soil and rock*. New Zealand Geotechnical Society Inc, 2005.

New Zealand Geotechnical Society Inc. 'Geotechnical issues in land development'. Proceedings of New Zealand Geotechnical Society Symposium, Hamilton, 1996.

### ROADS

Auckland Regional Transport Authority (ARTA). *Bus stop infrastructure design guidelines*. Auckland: ARTA, 2009.

Austrroads codes and guides, 2009. (Subject to the relevant New Zealand supplement).

Austrroads. *Guide to road design – Part 3: Geometric design*. Austrroads, 2009.

Austrroads Guide to road design – Part 4: Intersections and crossings – general 2009.

Austrroads Guide to road design – Part 4a: Unsignalised and signalised Intersections 2010.

Austrroads. *Guide to traffic management – Part 8: Local area traffic management*. Austrroads, 2008.

Cement and Concrete Association of Australia. *Guide to residential streets and paths*. Cement and Concrete Association of Australia, 2004.

New Zealand Transport Agency.

*Bridge manual*. (SP/M/022) 2nd ed. Wellington: NZTA, 2003.

*Cycle network and route planning guide*. Wellington: Land Transport Safety Authority, 2004.

Available at:  
<http://www.nzta.govt.nz/resources/cycle-network-and-route-planning/cycle-network.html>

*Pedestrian planning and design guide*. Wellington: NZTA, 2009. Available at: <http://www.nzta.govt.nz/resources/pedestrian-planning-guide/docs/pedestrian-planning-guide.pdf>

*Road safety audit procedures for projects* (Manual number TFM9). Wellington: Transfund New Zealand, 200

*RTS 11: Urban roadside barriers and alternative treatments*. Wellington: Land Transport Safety Authority, 1995. Available at: <http://www.nzta.govt.nz/resources/road-traffic-standards/docs/rts-11.pdf>

*RTS 18: New Zealand on-road tracking curves for heavy vehicles*. Wellington: Land Transport New Zealand, 2007. Available at: <http://www.nzta.govt.nz/resources/road-traffic-standards/rts-18.html>

*Stormwater treatment standard for state highway infrastructure*. Wellington: NZTA, 2010.

NZTA specifications (available at: <http://www.nzta.govt.nz/resources/index.html>)

B/2:2005	Construction
B/2:2005	Construction of unbound granular pavement layers
F/2:2000	Pipe subsoil drain construction
F/2 notes	Notes on pipe subsoil drain construction specification
M/1:2007	Roading bitumens
M/4:2006	Crushed basecourse aggregate
M/10:2005	Asphaltic concrete
P/3:1995	First coat sealing
P/4:1995	Resealing
P/9:1975	Construction of asphaltic concrete paving
T/10:2002	Skid resistance deficiency investigation and treatment selection

One Network Road Classification System, NZTA 2013

United Kingdom Department for Transport. *Manual for streets*. London: Thomas Telford Publishing, 2007.

United Kingdom Transport Research Laboratory. *TRL661 – The manual for streets: evidence and research*. TRL, 2007.

## STORMWATER, WASTEWATER, AND WATER SUPPLY

Auckland Regional Council

Technical Publication No. 124 (TP124) *Low impact design manual for the Auckland region*, 2000.

Technical Report 2008-20 *Application of low impact design to brownfield sites* (in preparation)

Technical Report 2009-83F *Integration of low impact design, urban design and urban form principles* (in preparation)

Australasian Society for Trenchless Technology (ASTT). *Guidelines for horizontal directional drilling, pipe bursting, microtunnelling and pipe jacking*. Greenwood, Western Australia: ASTT, 2009.

Austrroads. *Guide to road design – Part 5: Drainage design*. Austrroads, 2008.

Hicks, D M, and Mason, P D. *Roughness characteristics of New Zealand rivers*, Wellington: Water Resources Survey, DSIR Marine and Freshwater, 1991.

Janson, Lars-Eric. *Plastics pipes for water supply and sewage disposal*. 2003.

Lamont, P. 'Metrication: Hydraulic data and formulae.' *Water Services* Volume 81, numbers 972/3/4 (Reprinted by Kent Meters Ltd, UK)

Ministry for the Environment.

*Coastal hazards and climate change – A guidance manual for local government in New Zealand*. Wellington: Ministry for the Environment, 2008.

*Preparing for climate change – A guide for local government in New Zealand*. Wellington: Ministry for the Environment, 2008.

*Preparing for coastal change – A guide for local government in New Zealand.* Wellington: Ministry for the Environment, 2009.

*Preparing for future flooding – A guide for local government in New Zealand.* Wellington: Ministry for the Environment, 2010.

*Tools for estimating the effects of climate change on flood flow – A guidance manual for local government in New Zealand.* Wellington: Ministry for the Environment, 2010.

Ministry of Health. *Drinking-water standards for New Zealand 2005 (Revised 2008).* Wellington: Ministry of Health, 2008.

Najafi, M. *Trenchless technology – Pipeline and utility design, construction, and renewal.* McGraw-Hill, 2005.

New Zealand Transport Agency. *Bridge manual.* (SP/M/022) 2nd ed. Wellington: NZTA, 2003.

New Zealand Water and Wastes Association (Water New Zealand). *New Zealand pipe inspection manual.* Wellington: New Zealand Water and Wastes Association, 2006.

Stein, D. *Trenchless technology for installation of cables and pipelines.* Germany: Stein & Partner, 2005.

Uni-Bell. *Handbook of PVC pipe.* 4th ed. Dallas: Uni-Bell PVC Pipe Association, 2001.

Water Services Association of Australia (WSAA):

WSA 02-2014	Gravity Sewerage Code of Australia – 1999
WSA 03-2002	Water Supply Code of Australia – 1999 and 2002
WSA 04-2005	Sewage Pumping Station Code of Australia – 2005
WSA 06-2008	Vacuum Sewerage Code of Australia – 2008
WSA 07-2007	Pressure Sewerage Code of Australia – 2007

## **NETWORK UTILITY SERVICES**

Department of Labour. *Guide for safety with underground services.* Wellington: Department of Labour, 2002.

New Zealand Utilities Advisory Group (NZUAG). *National code of practice for utilities' access to the transport corridors.* Wellington: NZUAG.

## **NEW ZEALAND LEGISLATION**

The provisions of this Standard shall be read subject to the provisions of regional and district plans and to any applicable statutes, regulations, bylaws, and any subsequent amendments, including (but not limited to):

Building Act 2004, Building Regulations, and New Zealand Building Code (NZBC) 1992

Civil Defence Emergency Management Act 2002

Conservation Act 1987

Health and Safety in Employment Act 1992

Health (Drinking Water) Amendment Act 2007

*Heritage New Zealand Pouhere Taonga Act 2014*

Infrastructure (Amendments Relating to Utilities Access) Act 2010

Land Transfer Act 1952

Land Transport Rule (Traffic Control Devices) 2004

Local Government Act 1974 and Local Government Act 2002

Reserves Act 1977

Resource Management Act 1991

Utilities Access Act 2010

## RELATED DOCUMENTS

When interpreting this Standard it may be helpful to refer to other documents, including but not limited to:

### GENERAL

Land Information New Zealand. *New Zealand geodetic datum 2000 (NZGD2000)*

Ministry for the Environment. *Climate change effects and impacts assessment – A guidance manual for local government*. 2nd ed. Wellington: Ministry for the Environment, 2008.

### EARTHWORKS AND GEOTECHNICAL REQUIREMENTS

Auckland Regional Council. Technical Publication No. 90 (TP90) *Erosion and sediment control: guidelines for land disturbing activities in the Auckland Region*. Auckland: Auckland Regional Council, 1999.

Fraser Thomas Ltd (B J Brown, P R Goldsmith, J P M Shorten, L Henderson) BRANZ *Study Report 120, Soil expansivity in the Auckland region*. Judgeford: BRANZ, 2003.

Ministry for the Environment. *Planning for development of land on or close to active faults – A guideline to assist resource management planners in New Zealand*. Wellington: Ministry for the Environment, 2004.

Sanders, W, and Glassey, P. (Compilers). *Guidelines for assessing planning policy and consent requirements for landslide prone land*, GNS Science Miscellaneous Series 7. Lower Hutt: Institute of Geological and Nuclear Sciences Limited, 2007.

### ROADS

Concrete Masonry Association of Australia. *Concrete segmental pavements – Design guide for residential accessways and roads*. Sydney: Concrete Masonry Association of Australia, 1997.

Jones, P, Boujenko, N, and Marshall, S. *Link and place – A guide to street planning and design*. London: Landor Books, 2007.

Ministry of Justice. *National guidelines for crime prevention through environmental design in New Zealand Part 1: Seven qualities of safer places, and Part 2: Implementation guide*. Wellington: Ministry of Justice, 2005.

Ministry of Transport *Government policy statement on land transport funding 2009/10 – 2018/19*. Wellington: Ministry of Transport, May 2009.

Ministry of Transport. *Safer journeys – New Zealand's road safety strategy 2010 – 2020*. Wellington: Ministry of Transport, 2010.

Ministry of Transport. *The New Zealand transport strategy 2008*. Wellington: Ministry of Transport, 2008.

New Zealand Transport Agency

*Traffic note 48 – Light vehicle sizes and dimensions: Street survey results and parking space requirements – Information*. Land Transport New Zealand, December 2004. Available at: <http://www.nzta.govt.nz/resources/traffic-notes/docs/traffic-note-48.pdf>

*Manual of traffic signs and markings (MOTSAM) Parts 1 – 4*

*NZTA register of network standards and guidelines*. Wellington: NZTA, 2009. Available at: <http://www.nzta.govt.nz/resources/nzta-register-network-standards-guidelines/>

SNZ HB 44:2001 *Subdivision for people and the environment*. Wellington: Standards New Zealand, 2001.

NZ Utilities Advisory Group (Roadshare). *The National Code of Practice for Utility Operators' Access to Transport Corridors*, 2011.

### STORMWATER, WASTEWATER, AND WATER SUPPLY

Auckland City Council. *On-site stormwater management manual*. Auckland: Auckland City Council, 2002.

Auckland City Council. *Soakage design manual*. Auckland: Auckland City Council, 2003.

Auckland Regional Council. Technical Publication No. 10 (TP10) *Design guideline manual stormwater treatment devices*, 2003.

Auckland Regional Council. Technical Publication No. 108 (TP108) *Guidelines for stormwater runoff modelling in the Auckland region*, 1999.

Christchurch City Council. *Waterways, wetlands and drainage guide – Part A: Visions and Part B: Design*. 2003. Available at: <http://www.ccc.govt.nz/cityleisure/parkswalkways/environmentecology/waterwayswetlandsdrainageguide/index.aspx>

Environment Protection Authority (EPA) Victoria. *Maintaining water sensitive urban design elements*. Melbourne: EPA Victoria, 2008.

Greater Wellington Regional Council. *Fish friendly culverts*. June 2003. Available at: <http://www.gw.govt.nz/bridges-and-culverts/>

New Zealand Water Environment Research Foundation (NZWERF) *On-site stormwater management guideline*. Wellington: NZWERF, 2004.

North Shore City Council. *Bioretention guidelines*. Takapuna: North Shore City Council, 2008.

Puddephatt, J, and Heslop, V. *Guidance on an integrated process – Designing, operating and maintaining low impact urban design and development devices*. Landcare Research, July 2008.

Sustainable urban drainage systems (SUDS) design manuals for countries in the United Kingdom.

Water sensitive urban design (WSUD) manuals from various Australian states and cities.

Wellington City Council. *Water Sensitive Urban Design – A Guide for WSUD Stormwater Management in Wellington*.

Auckland City Council. *Auckland Design Manual – Water Sensitive Design*.

Christchurch City Council. *Rain Garden Design, Construction and Maintenance Manual, May 2016*.

Taranaki Regional Council Regional Fresh Water Plan 2001

## WEBSITES

Auckland Regional Council	<a href="http://www.arc.govt.nz">http://www.arc.govt.nz</a>
Austrroads	<a href="http://www.austrroads.com.au">http://www.austrroads.com.au</a>
Ministry for the Environment	<a href="http://www.mfe.govt.nz">http://www.mfe.govt.nz</a>
National Pest Plant Accord	<a href="http://www.biosecurity.govt.nz/nppa">http://www.biosecurity.govt.nz/nppa</a>
<i>Heritage New Zealand Pouhere Taonga Act</i>	<a href="http://www.heritage.org.nz">http://www.heritage.org.nz</a>
New Zealand Legislation	<a href="http://www.legislation.govt.nz">http://www.legislation.govt.nz</a>
New Zealand Transport Agency	<a href="http://www.nzta.govt.nz/">http://www.nzta.govt.nz/</a>
Plastics Industry Pipe Association of Australia:	<a href="http://www.pipa.com.au">http://www.pipa.com.au</a>
Trips Database Bureau	<a href="http://www.tdbonline.org/home">http://www.tdbonline.org/home</a>
Water Services Association of Australia	<a href="https://www.wsaa.asn.au/">https://www.wsaa.asn.au/</a>

## LATEST REVISIONS

The users of this Standard should ensure that their copies of the abovementioned New Zealand Standards are the latest revisions. Amendments to referenced New Zealand and Joint Australian/New Zealand Standards can be found on <http://www.standards.co.nz>.

## REVIEW OF STANDARDS

Suggestions for improvement of this Standard will be welcomed. *Suggestions for improvements to NPDC, STDC and SDC elements of this standard (as noted by local amendments shown in italics) should be sent to the respective Councils. Suggestions for changes to NZS 4404:2010 should be sent to the Chief Executive, Standards New Zealand, Private Bag 2439, Wellington 6140.*

DRAFT FOR CONSULTATION

## FOREWORD

A significant proportion of all new infrastructure is created by land development and subdivision projects. As a community, we need to get this right. This is why NZS 4404:2010 aims to encourage good urban design and remove road blocks to liveability and economic development in communities.

Some of the key changes from NZS 4404:2004 are:

- (a) That road design needs to allow 'context' or 'place' to be given significant emphasis, and to require roads to achieve safe (slower) operating speeds;
- (b) An emphasis on managing and treating stormwater 'before it gets into a pipe', together with a requirement to consider climate change and potential sea level rise;
- (c) Swales, natural or artificial waterways, ponds and wetlands, for example, may in certain circumstances be not only part of the stormwater system, but also be a preferred solution, especially if low impact on receiving waters downstream is critical;
- (d) The sections on landscaping and reserves have been combined and significantly rewritten; and
- (e) The section on utility services (section 8) has also been significantly amended in accordance with the latest network authorities' codes.

The change in the title from 'engineering' to 'infrastructure' signals that good subdivision design involves a multidisciplinary collaborative approach. NZS 4404 was first published in 1981 as the Code of practice for urban land subdivision. In 2004 it became the Standard for Land development and subdivision engineering. In response to submissions on the draft 2010 version, and to clarify the place and role of NZS 4404, the committee has decided that the new name, Land development and subdivision infrastructure, best reflects its function.

NZS 4404:2010 is applicable to greenfield, urban, and brownfield redevelopment projects. It provides territorial authorities (TAs) and developers a Standard for the design and construction of subdivision infrastructure. It can be used on its own or, together with local codes, as a means to comply with Resource Management Act (RMA) consent conditions. It is not an urban design policy, guide, or method of master planning.

The impetus for the review of NZS 4404:2004 came from requests for changes from:

- (f) The New Zealand Transport Agency (NZTA);
- (g) Local Government New Zealand (LGNZ);
- (h) The Ministry for the Environment (MfE);
- (i) Pipe manufacturers;
- (j) Territorial authorities (TAs), and;
- (k) A number of individual users of the Standard.

The revision was sponsored by LGNZ, NZTA, and MfE.

Innovative subdivision has been discouraged to some extent under the 2004 version of NZS 4404. The objectives of the 2004 version were to permit alternative solutions. However, in practice, well designed solutions that were not in accordance with the acceptable solutions specified by the Standard often had difficulty gaining RMA consents. This led to delays and additional costs or a less desirable design being adopted.



The review committee therefore challenged itself to produce a new Standard that:

- (l) Encourages sustainable and modern design;
- (m) Provides some certainty for designers and TAs; and
- (n) Prevents the outcomes that can arise when the sole focus is cost minimisation, and adherence to minimum standards.

The committee recognises that there are tensions between these sometimes conflicting objectives and has balanced those tensions when deciding between allowing flexibility and prescribing clear rules.

The committee would like to thank the many people who between them made more than 1,900 comments and suggestions for improvements. The submissions were overwhelmingly in support of the new direction of the Standard. Every single comment and suggestion was reviewed by committee members and many have found their way into the final document. It is a significantly better Standard because of those submissions. The committee would also like to thank all those organisations that have allowed their documents to be used in the Standard or as reference documents. The committee has tried not to 'reinvent the wheel' where existing documents provide the appropriate standards. This is why many other publications including Standards are referenced by this Standard.

Finally, we all need to applaud and be grateful for the countless hours and effort committee members contributed to this review. The only payment is the satisfaction of a well-written Standard that enjoys good community support. It is a Standard that helps develop people-oriented communities with land development and subdivision infrastructure that has a long life, and the minimum environmental impact compatible with good urban design.

## OUTCOME STATEMENT

This Standard provides territorial authorities, developers, and their professional advisors with standards for design and construction of land development and subdivision infrastructure. NZS 4404:2010 encourages sustainable development and modern design that emphasises liveability and environmental quality. It will also provide as much consistency as possible on land development and subdivision infrastructure while still allowing flexibility for local variations to suit local circumstances.

## NOTES

DRAFT FOR CONSULTATION

# New Zealand Standard

## Land Development and Subdivision Infrastructure

### 1 GENERAL REQUIREMENTS AND PROCEDURES

#### 1.1 Scope

*This Standard is recommended for adoption by territorial authorities (TAs). It is applicable to greenfield and infill development, as well as brownfield redevelopment projects. The Standard also serves as a basis for technical compliance for the subdivision and development of land where these activities are subject to the Resource Management Act. TAs may develop their own standards for land development or tailor outcomes sought to the particular needs of their local environments through their design guides, district plans, and codes of practice or development engineering manuals. However, it is recommended that NZS 4404 be adopted as the basis for these standards.*

*This document sets out the minimum standards of technical performance and quality for the subdivision and development of land and infrastructure required by, or undertaken by, NPDC, STDC and SDC and provides guidelines as to how these standards may be met. This standard supersedes the Council's Code of Practice for Infrastructure 2009 and the Council's 1997 Code of Practice.*

Section 1 of this Standard concerns matters of general application and general requirements to be observed. Sections 2 to 8 of this Standard provide good practice guidelines on particular types of infrastructure to be provided.

##### *C1.1*

*This Standard does not include a statement of all minimum requirements for land development and subdivision infrastructure. It is not an urban design guide. TAs may specify their own minimum requirements, citing this Standard or their own bylaws or district plan as appropriate.*

*This Standard does not deal with the processes of compliance with the requirements of a district plan for subdivision or development activities or obtaining a resource consent for such activities. For these purposes, refer to the New Plymouth, South Taranaki and Stratford District Plans.*

#### 1.2 Interpretation

##### 1.2.1 General

- 1.2.1.1 The full titles of referenced documents cited in this Standard are given in the list of referenced documents.
- 1.2.1.2 The word 'shall' refers to practices which are mandatory for compliance with the Standard. The words 'should' or 'may' indicate a recommended practice.
- 1.2.1.3 Clauses prefixed by 'C' and printed in italic type are intended as comments on the corresponding mandatory clauses. They are not to be taken as the only or complete interpretation of the corresponding clause. The Standard can be complied with if the comment is ignored.
- 1.2.1.4 The terms 'informative' and 'normative' have been used in this Standard to define the application of the appendix to which they apply. A 'normative' appendix is an integral part of a Standard, whereas an 'informative' appendix is only for information and guidance. Informative provisions do not form part of the mandatory requirements of this Standard.

- 1.2.1.5** Schedules containing information to be provided in certificates or as-built plans are included at the end of sections to which they relate. Each schedule is copyright waived, meaning it may be photocopied for use in accordance with the Standard.

## 1.2.2 Definitions

For the purpose of this Standard, the following definitions shall apply *and plural words have the same definition of singular words*:

<b>Accessway</b>	<i>A link between public places not intended for motor vehicle movement.</i>
<b>Annual exceedance probability (AEP)</b>	The probability of exceedance of a given occurrence, generally a storm, in a period of 1 year (1% AEP is equivalent to a 1 in 100-year storm).
<b>Approved Connections Contractor – Drainage (Not Applicable for STDC or SDC)</b>	<p><i>A contractor approved by the Council to work on:</i></p> <ul style="list-style-type: none"> <li>• <i>Sewer connections to manholes or to mains up to and including 225 mm mains.</i></li> <li>• <i>Stormwater connections to manholes, ramps or kerbs. No connections larger than 300 mm nominal bore.</i></li> </ul> <p><i>Any connections larger than these will be at the discretion of the TA.</i></p>
<b>Approved Connections Contractor – Water, Category A (Not Applicable for STDC or SDC)</b>	<i>A contractor approved by the Council to work on connections of up to 25 mm nominal bore to live mains up to and including 200 mm nominal bore. Not approved to shut down or isolate operational mains.</i>
<b>Approved Connections Contractor – Water, Category B (Not Applicable for STDC or SDC)</b>	<i>A contractor approved by the Council to work on connections of up to 50 mm nominal bore to live mains up to and including 200 mm nominal bore. Not approved to shut down or isolate operational mains, however can put in a request to Council for permission to operate isolation valves on a case by case basis.</i>
<b>Approved Contractor/Service Provider</b>	<i>A contractor approved by the Council to work on Council sewer mains, water mains, roads, property or parks.</i>
<b>Boundary Box</b>	<i>A standard box at the property boundary containing a service valve, a double check valve to prevent backflow and provision for the installation of a water meter.</i>
<b>Boundary Chamber</b>	<i>An inspection chamber at the property boundary provided with a lid at ground level.</i>
<b>Carriageway</b>	That part of a road consisting of the movement lane, sealed shoulder, and includes parking and loading areas when provided within the road.
<b>Corridor manager</b>	<p>Has the same meaning given to it by the proposed utilities access legislation.</p> <p>NOTE – In preparing NZS 4404:2010, the Committee made every effort to align it with the infrastructure legislation and the utilities access legislation still before Parliament at the time this Standard is published. Readers will need to satisfy themselves on the final form of the definitions of code (see section 8) and corridor manager once this utilities access legislation comes into effect.</p>
<b>Crime prevention through environmental design</b>	Has a set of four principles: surveillance, access management, territorial reinforcement, and quality environments of the built environment. These CPTED principles lead to a reduction in the incidence and fear of crime as well as an improvement in the quality of life.
<b>Developer</b>	An individual or organisation having the financial responsibility for the development project. Developer includes the owner.

<b>Developer's professional advisor</b>	<i>A suitably qualified person, appointed by the developer, who shall be responsible for:</i> (a) The investigation, design and obtaining of approvals for construction; (b) Contract administration and supervision of construction; (c) Certification upon completion of construction.
<b>Drain</b>	<i>As defined in the Land Drainage Act 1908 or Public Works Act 1982.</i>
<b>Drinking water</b>	As defined in the Health (Drinking Water) Amendment Act.
<b>Dwelling unit</b>	Any building or group of buildings, or part thereof used, or intended to be used principally for residential purposes and occupied, or intended to be occupied by not more than one household.
<b>Earthworks</b>	Any alteration to the contours, including the excavation and backfilling or recompaction of existing natural ground and the stripping of vegetation and topsoil.
<b>Footpath</b>	So much of any road or other area as is laid out or constructed by authority of the TA primarily for pedestrians; and may include the edging, kerbing, and channelling of the road.
<b>Freeboard</b>	A provision for flood level design estimate imprecision, construction tolerances, and natural phenomena (such as waves, debris, aggradations, channel transition and bend effects) not explicitly included in the calculations.
<b>Furniture (Street or Roadside)</b>	<i>Any TA owned assets in the road reserve for the control, guidance and safety of traffic and convenience of road users not associated with the carriageway.</i>
<b>Geo-professional</b>	A chartered professional engineer (CPEng) or an engineering geologist with recognised qualifications and experience in geotechnical engineering, and experience related to land development.
<b>Ground</b>	Describes the material in the vicinity of the surface of the earth whether soil or rock.
<b>Independent qualified person (IQP)</b>	A specialist approved by the territorial authority and having the appropriate skills and qualification to carry out specific procedures.
<b>Inflow</b>	<i>Water discharged into a private drain from non-complying connections or other drainlaying faults. It includes stormwater entering through illegal downpipe connections or from low gully traps.</i>
<b>Level of Protection</b>	<i>A concept relating the severity of a storm with the combined flow capacity or the primary and secondary flow paths.</i>
<b>Level of Service</b>	<i>The defined quality for a particular service, against which performance may be measured.</i>
<b>Low impact design (LID)</b>	An approach to land development and stormwater management that recognises the value of natural systems in order to mitigate environmental impacts and enhance local amenity and ecological values. LID is synonymous with Water Sensitive Design in the New Plymouth District.
<b>Mobility crossing</b>	<i>Also known as a pram crossing or kerb ramp, is a modified section of kerb, channel, and footpath constructed between a footpath and the carriageway, designed to allow prams, trolleys, wheelchairs, mobility scooters, and similar wheeled devices to transition smoothly from the footpath to the carriageway.</i>
<b>Movement lane</b>	That part of the formed and sealed road that serves the link function in a road. It may have a shared use for other activities such as walking, cycling, parking, and play.
<b>Network utility operator</b>	Has the same meaning given to it by section (s.) 166 of the Resource Management Act.

<b>Owner</b>	In relation to any land or interest in land, includes an owner of the land, whether beneficially or as trustee, and their agent or attorney, and a mortgagee acting in exercise of power of sale; and also includes the Crown, the Public Trustee, and any person, TA, board, or other body or authority however designated, constituted, or appointed, having power to dispose of the land or interest in land by way of sale.
<b>Point of Discharge</b>	<i>The point on a sewer connection denoting the boundary of responsibility between the property owner and the Council. (Refer to the Council Bylaws for a comprehensive definition).</i>
<b>Point of Supply</b>	<i>The point on a service pipe which denotes the boundary of responsibility between the property owner or water user and the Council. Generally the tail piece of the boundary box or service valve (toby) regardless of the property boundary. (Refer to the Council Bylaws for a comprehensive definition).</i>
<b>Potable water</b>	As defined in the Health (Drinking Water) Amendment Act.
<b>Primary flow</b>	The estimated surface water run-off specified to be managed by the primary stormwater system. This flow may be piped or contained within relatively narrow confines under public control by reserve or easement.
<b>Primary Flow Path</b>	<i>A system of pipes and open drains intended to convey stormwater to an outfall.</i>
<b>Private road</b>	Any roadway, place, or arcade laid out within a district on private land by the owner of that land intended for the use of the public generally and has the same meaning given to it by section 315 of the Local Government Act 1974.
<b>Private way</b>	Any way or passage over private land within a district, the right to use which is confined or intended to be confined to certain persons or classes of persons, and which is not thrown open or intended to be open to the use of the public generally and includes any shared access or right of way and has the same meaning given to it by s. 315 of the Local Government Act 1974.
<b>Receiving water</b>	The water body that receives the discharge from the stormwater conveyance system and is usually a watercourse, stream, river, pond, lake, or the sea.
<b>Rider Main</b>	<i>A small diameter (&lt;100mm) water main laid to service all lots not serviced by a distribution main.</i>
<b>Road</b>	Has the same meaning given to it by section 315 of the Local Government Act 1974.
<b>Secondary flow</b>	The estimated surface water run-off in excess of the primary flow. In most cases this flow will be managed in an overland flowpath or ponding area that is protected by public ownership or easement.
<b>Secondary Flow Path</b>	<i>The route taken by stormwater when the capacity of the primary flow path is exceeded or restricted by blockage.</i>
<b>Soak Hole</b>	<i>A means of disposing of stormwater within a property by providing a hole in the ground into which runoff initially collects. Over time water percolates into the ground water system.</i>
<b>Specific Design</b>	<i>An item or construction method shall be designed and/or specified by a suitably qualified person and full details of the design or description of the construction method shall be presented on the drawings and/or in the project specification.</i>
<b>Stormwater</b>	Rainwater that does not naturally percolate into the ground or evaporate, but flows via overland flow, interflow, channels, or pipes into a defined surface water channel, open watercourse, or a constructed infiltration facility.
<b>Street</b>	Has the same meaning as 'road' as defined by s. 315 of the Local Government Act 1974.

<b>Surface water run-off</b>	All naturally occurring water, other than subsurface water, which results from rainfall on the site or water flowing onto the site, including that flowing from a drain, stream, or river.
<b>Survey plan</b>	A survey plan under s. 2 of the Resource Management Act.
<b>Suitably qualified</b>	<p><i>A suitably qualified and/or experienced professional who possesses relevant qualification, experience and expertise in the areas of land development or natural hazard (excluding geotechnical) disciplines.</i></p> <p><i>Any professional can undertake the role of the SQE Professional where they meet one of the following criteria:</i></p> <p>(a) <i>A Chartered Professional Engineer.</i></p> <p>(b) <i>A person with relevant qualifications, skills and industry experience, who can demonstrate to Council a track record of undertaking investigation, design, supervision and certification of land development works relating to either natural or man-made hazards (excluding geotechnical) or in land development disciplines, that is acceptable to Council.</i></p>
<b>Swale</b>	A constructed watercourse shaped or graded in earth materials and stabilised with site-suitable vegetation or rocks, for the safe conveyance, <i>percolation</i> and water-quality improvement of stormwater run-off.
<b>Target operating speed</b>	The desired maximum speed for motor vehicles identified by the designer to suit the land use context and road classification. This speed can be managed by physical and psychological devices such as narrowed movement lanes, reduced forward visibility, parking, slow points, build outs, leg lengths, chicanes, planting, landscaping, street furniture, and art works.
<b>Territorial authority</b>	A territorial authority (TA) defined in the Local Government Act 2002.
<b>Trunk Main</b>	<p><i>A trunk main is a pipe which forms a part of the Council's reticulation system regardless of duty, and includes:</i></p> <p>a) <i>All sewer mains 300mm and larger in diameter;</i></p> <p>b) <i>A water main (of any size) from a reservoir to a reticulation system or cross-connecting reservoirs or reticulation systems;</i></p> <p>c) <i>All water mains 250mm and larger in diameter.</i></p>
<b>Table Drain</b>	<i>The shallow side drain of a road adjacent to the shoulder, having its invert lower than the pavement base.</i>
<b>Vehicle crossing</b>	<i>The formed section of driveway constructed between the road boundary and the carriageway, designed for the purpose of conveying vehicles over the footpath and/or grass berm to the carriageway.</i>
<b>Wāhi tapu</b>	Means a place sacred to Māori in the traditional, spiritual, religious, ritual, or mythological sense.
<b>Watercourse</b>	<i>Has the same meaning as defined in the Land Drainage Act 1908.</i>
<b>Water Table</b>	<i>Free water level in saturated soil.</i>
<b>Wastewater</b>	Water that has been used and contains unwanted dissolved or suspended substances from communities, including homes, businesses, and industries.

### 1.2.3 Abbreviations

The following abbreviations are used in this Standard:

ABS	acrylonitrile butadiene styrene
AEP	annual exceedance probability
Austrroads	Association of Australian and New Zealand Road Transport and Traffic Authorities
AV	air valve

°C	degrees Celsius
CBD	central business district
CBR	California bearing ratio
CCTV	closed circuit television
CLS (SCL)	concrete lined steel (steel concrete lined)
CPTED	Crime prevention through environmental design
DI	ductile iron
DN	nominal diameter under the pipe manufacturing standard
du	dwelling unit
ESA	equivalent standard axle
FAC	free available chlorine
FAR	floor-to-area ratio
FL	Flange
FSL	finished surface level
GL	ground level
g/m <sup>3</sup>	grams per cubic metre
GRP	glass reinforced plastic
H	head (in metres)
h	hour
ha	hectare
HCV	<i>Heavy Commercial Vehicle</i>
HDD	horizontal directional drilling
HPT	<i>Heritage NZ</i>
HPS	<i>High Pressure Sodium</i>
IQP	independent qualified person
km	kilometre
km/h	kilometres per hour
kPa	kilopascal
L	litre(s)
LID	low impact design
LPS	<i>Low Pressure Sodium</i>
m	metre
MDD	maximum dry density
MH	manhole or maintenance hole
MHL	<i>Magnesium Halogen Lamp</i>
min	minute(s)
MPa	megapascal
MS	maintenance shaft
m/s	metres per second
m <sup>3</sup> /s	cubic metres per second
mm	millimetres
NAASRA	National Association of Australian State Road Authorities



NES	National Environmental Standard
NIWA	National Institute of Water and Atmospheric Research
NPDC	<i>New Plymouth District Council</i>
NPS	National Policy Statement
NZBC	New Zealand Building Code
NZTA	New Zealand Transport Agency
OSH	Occupational Safety and Health
p	Person
PE	polyethylene
PE 80B	polyethylene with minimum required strength (MRS) of 8 MPa as defined in AS/NZS 4130 and AS/NZS 4131
PE 100	polyethylene with MRS of 10 MPa as defined in AS/NZS 4130 and AS/NZS 4131
PF	peaking factor
PIPA	Plastics Industry Pipe Association of Australia Ltd
PN	nominal pressure class (maximum rated operating pressure)
PP	Polypropylene
PRV	pressure reducing valve
PVC	polyvinyl chloride
PVC-U	unplasticised polyvinyl chloride
PVC-M	modified polyvinyl chloride
PVC-O	orientated polyvinyl chloride
RMA	Resource Management Act
RRJ	rubber ring joint
s.	section
Soc	socket
SDC	<i>Stratford District Council</i>
STDC	<i>South Taranaki District Council</i>
STP	specified test pressure
TA	territorial authority
TMS	terminal maintenance shaft
UV	ultraviolet
VC	vitrified clay
vpd	vehicles per day

### 1.3 Context

This Standard is relevant to Acts such as the Resource Management Act, Building Act, Heritage New Zealand Pouhere Taonga Act and other legislation. The purpose of NZS 4404:2010 is to provide standards for the implementation of well-designed land development and subdivision infrastructure projects that have obtained the necessary resource consents under the RMA, and comply with other legislation. TAs will be able to invoke compliance with this Standard and their own local additions and variations, to ensure that the sustainability, urban design, and environmental impact objectives of land development and subdivision projects are carried through to completion. The interrelationship between this Standard and these Acts is outlined below.

The Standard also provides best practice land development and subdivision infrastructure techniques in low impact design, climate change, and urban design.

### 1.3.1 Resource Management Act

The Resource Management Act 1991 (RMA) is the principal statute under which the development and subdivision of land is controlled.

Regional and district plans prepared under the RMA are the key resource management instruments that TAs implement to achieve sustainable management of natural and physical resources, which is the overarching purpose of the RMA.

This Standard does not have a binding effect unless incorporated into a regional/district plan or bylaw. If the Standard is not referred to in the plan or any bylaw, the Standard can still serve as a technical compliance manual to assist in guiding decision-making and forming conditions of resource consent.

A national policy statement (NPS) and national environmental standard (NES) may also apply to a proposed development in addition to regional and district planning documents. However NPS and NES only apply once they are finalised and gazetted whereas regional and district plan provisions may apply to consent applications as soon as they are notified.

#### C1.3.1

*Over time, central government may develop other NPS and NES which may affect decision-making by TAs on land development and subdivision, including national policy on freshwater management, sea level rise, and flood risk. The Ministry for the Environment's website should be referred to for any relevant NPS and NES.*

The protection of historic heritage from inappropriate subdivision, use, and development is a matter of national importance under s. 6(f) of the RMA. The RMA's definition of historic heritage includes: historic sites, structures, places, and areas; archaeological sites; sites of significance to Māori including wāhi tapu; and surroundings associated with the natural and physical resources. Therefore regional/district plans should be reviewed to ascertain whether any development proposal affects historic heritage. Most plans have a historic heritage schedule, which lists the item protected, its location, and its sensitivity. A precautionary approach should be taken prior to any land development and subdivision infrastructure affecting historic heritage, with the TA consulted at the earliest stage (see 1.3.2).

Where applications for resource consents may affect sites of significance to Māori, consultation with the appropriate tangata whenua groups should occur prior to finalising plans or submitting applications for resource consent in order to give effect to Part II of the RMA.

### 1.3.2 Heritage New Zealand Pouhere Taonga Act

*In addition to the RMA, the Heritage New Zealand Pouhere Taonga Act regulates the modification or destruction of archaeological sites on all land and provides for substantial penalties for unauthorised modification or destruction of these sites.*

*An archaeological site is defined in the Act as any place in New Zealand (including buildings, structures or shipwrecks) that was associated with pre-1900 human activity, where there is evidence relating to the history of New Zealand that can be investigated using archaeological methods.*

*The Act makes it unlawful for any person to modify or destroy, or cause to be modified or destroyed, the whole or any part of an archaeological site without the prior authority of HNZPT. This is the case regardless of whether:*

- (a) *The site is registered or recorded by the council in planning documents;*
- (b) *The land on which the site is located is designated;*
- (c) *The activity is permitted under the district or regional plan; or*
- (d) *A resource or building consent has been granted.*

*Approval from HNZPT is required if a site is affected, in addition to any council approval that may be required.*

*Furthermore, if the site is known to be associated with pre-1900 human activity, or there is reasonable cause to suspect such an association, the developer should consult with HNZPT prior to undertaking any earthworks or ground disturbance. If a previously unknown site is uncovered during earthworks, approval from HZNPT may also be needed before work can continue.*

### 1.3.3 Building Act

The Building Act provides a national framework for building control to ensure that buildings are safe and sanitary and have suitable means of escape from fire. The Building Regulations made under the Act provide the mandatory requirements for building control in the form of the New Zealand Building Code. The Building Code contains the objective, functional requirements, and performance criteria that building works shall achieve.

Where the development of land and subdivision infrastructure involves the creation of structures with associated site works, including specific aspects of stormwater management and the interaction of buildings, fences, and walls with stormwater flows, the requirements of the Building Act shall be observed. Nothing in this Standard shall detract from the requirements of the Building Act or the Building Code.

#### C1.3.3

*Systems owned or operated by a network utility operator for the purpose of reticulation are not included in the definition of building under the Building Act.*

### 1.3.4 Other legislation

The Reserves Act, Conservation Act, and other Acts may also require consideration when undertaking land development and subdivision infrastructure. Covenants (a legal restriction or agreement recorded on the title of a property that is a matter of private contract) may also require consideration. For example, a Queen Elizabeth II Act Open Space Covenant is a legally binding protection document agreed between a landowner and the QEII National Trust.

## 1.4 Low impact design

Low impact design (LID) is both a design approach and a range of structural techniques that can be applied to urban development and stormwater management. As a design approach, LID provides an opportunity to identify and recognise natural features and integrate these into the design of development layouts in order to minimise environmental impacts or enhance natural features. The integration of natural processes in the design stage of a development can result in more attractive, multifunctional landscapes with greater social, environmental, cultural, and transport outcomes.

Low impact design solutions that use natural processes and add value to urban environments are the preferred approach.

*LID is synonymous with Water Sensitive Design within the New Plymouth District.*

## 1.5 Climate change

Climate change is likely to increase the magnitude of some hazards, therefore it is important to incorporate risk management in the design of infrastructure supporting new developments to maintain the same level of service throughout the design lifetime. The design of infrastructure for land development and subdivision needs to provide for the impact of sea level rise and the increased frequency of extreme weather events.

#### C1.5

*Amendments to the Resource Management Act, the Local Government Act 2002, and the Building Act require TAs to have particular regard to the effects of climate change when making decisions under these Acts.*

*In coastal areas, the New Zealand Coastal Policy Statement 2010 (policy 25) requires TAs to consider the location of any new subdivisions in the context of avoiding or reducing potential coastal hazards.*

*The government is considering the development of a number of other national policy instruments which may affect decision-making by territorial authorities, including a 'National environmental standard on sea level rise' and a 'National policy statement on flood risk'. These would not take effect until they are gazetted.*

## 1.6 Urban design protocol

The New Zealand urban design protocol seeks to ensure that the design of buildings, places, spaces, and networks that make up our towns and cities, work for all of us, both now and in the future. NZS 4404 includes recommended best practices that support urban design protocol initiatives. The New Zealand urban design protocol identifies seven essential design qualities for good urban design:

- (a) Context: seeing that buildings, places, and spaces are part of the whole town or city;
- (b) Character: reflecting and enhancing the distinctive character, heritage, and identity of our urban environment;
- (c) Choice: ensuring diversity and choice for people;
- (d) Connections: enhancing how different networks link together for people;
- (e) Creativity: encouraging innovative and imaginative solutions;
- (f) Custodianship: ensuring design is environmentally sustainable, safe, and healthy;
- (g) Collaboration: communicating and sharing knowledge across sectors, professions, and with communities.

The New Zealand urban design protocol has been the primary influence on the urban layouts that are encouraged in this Standard.

*New Plymouth District Council is a signatory to the Urban Design Protocol.*

## 1.7 Requirements for design and construction

### 1.7.1 Investigation and design

All investigation, calculations, design, supervision, and certification of the infrastructure outlined in this Standard shall be carried out by or under the control of persons who:

- (a) Are experienced in the respective fields;
- (b) Hold appropriate membership in the respective professional bodies or are recognised by TAs as having proven experience;
- (c) Have appropriate professional indemnity insurance and public liability insurance.

The provisions of this Standard do not reduce the responsibility of those professionals to exercise their judgement and devise appropriate solutions for the particular circumstances of each development.

### 1.7.2 Construction

All construction carried out in any development shall be done by persons who:

- (a) Have the appropriate experience and qualifications in the relevant areas;
- (b) Have the appropriate equipment;
- (c) Have the appropriate public liability insurance;
- (d) Meet the requirements of the Health and Safety in Employment Act.

## 1.8 Approval of design and construction

### 1.8.1 Documents to be submitted for design approval

1.8.1.1 Prior to, or as a condition of, granting a resource consent for subdivision or development of land, or as otherwise required by a district or regional plan, or as otherwise considered necessary by the TA when considering applications to construct infrastructure, the TA may require documents to be submitted including the following:

- (a) Design and construction documentation including drawings, specifications, and calculations for the following:
  - (i) Earthworks and geotechnical requirements
  - (ii) Roading and site access including a design and access statement (see 3.2.6) and a road safety audit (see 3.2.7)
  - (iii) Stormwater
  - (iv) Wastewater
  - (v) Water supply
  - (vi) *Landscape, including landscape plan and methodology including planting area preparation, maintenance requirements and type of fencing to be provided (as per Council's Parks Standards Manual).*
  - (vii) Network utility services;
- (b) A geo-professional's report on the suitability of the land for subdivision or development;
- (c) Other reports as considered necessary by the TA in the circumstances of the proposed infrastructure in order to meet the requirements of this Standard;
- (d) A design certificate in the form of the certificate in Schedule 1A.

### 1.8.2 Drawings

#### 1.8.2.1 General

Design drawings shall be prepared in accordance with the TA's practices. Except where otherwise notified, the requirements are as set out in this section and in sections 2 to 8 of this Standard. Drawings shall be approved by the TA. All drawings shall be provided in a form required by the TA.

Drawings shall be to adequate detail to clearly illustrate the proposals and enable assessment of compliance with this Standard and enable accurate construction.

#### 1.8.2.2 Composition of drawings

Design drawings generally include the following:

- (a) A locality plan giving the overall layout and location;
- (b) Detailed plans, longitudinal sections, cross sections, and diagrams of the proposed developments;
- (c) Special details where the standard drawings are not sufficient;
- (d) A north point and level datum, the scale or scales used, the date of preparation and the date of any amendments, the designer's name and contact details, and a unique number or identifier.
- (e) *All levels shall be shown on a plan and shall be in terms of a recognised datum. The following hierarchical precedence is currently in effect for datums:*
  1. *The recognised LINZ datum (i.e. Taranaki Vertical Datum 1970).*
  2. *A local peg is only acceptable in a rural area.*

*Detailed plans are required for each service on a separate sheet (paper) or layers (electronic). A general arrangement plan to show all services is also required.*

#### **1.8.2.3 Scale**

The scale for plans is generally 1:500 but other accepted scales may be used to suit the level of detail on the plans. Special details shall be to scales appropriate for clarity. Individual TAs may require other specific scales to be used.

#### **1.8.2.4 Content of drawings**

The following information when relevant shall be shown on the design drawings:

- (a) The extent of the construction showing existing and proposed roads, and the relationship with adjacent construction, services, or property;
- (b) Significant existing vegetation to be removed and any special or protected trees, areas of heritage significance, and existing water bodies that may be affected by the construction;
- (c) The extent of earthworks, including earthworks on proposed reserves, existing and proposed contours, areas of cut and fill, batter slopes, subsoil drainage, and silt control measures both temporary and permanent;
- (d) The design of proposed roads (and their connections with existing roads), including longitudinal and cross section plans, horizontal and vertical geometry and levels, typical cross sections, details of proposed pavement surface, kerbing, swales, berms, footpaths, cycle paths, tree planting, road marking and signals, and all other proposed road furniture;
- (e) The horizontal and vertical location and alignment, lengths, sizes, materials, minimum cover, position relative to other services of all proposed water, wastewater, and stormwater systems and service connections, valves, hydrants, manholes, bends, tees, meters and backflow devices, and services that may be reconnected or plugged, and any proposed overland stormwater flow path;
- (f) Details and location of mechanically restrained portions of pipelines, pipeline bridges, pumping stations, reservoirs, intake and outlet structures and the location of surface obstructions, hazards, or other features that may be affected by the construction;
- (g) For water mains, the nominal static pressure head at the point of connection and at the lowest point; design pressure and maximum design pressure;
- (h) Details and location of existing and proposed telecommunications, electricity and gas supply, and street lighting layout, including proposed underground and above ground junction boxes, transformers and similar equipment. This information is typically provided by the service authorities once other design drawings are finalised and approved;
- (i) Details of proposed landscaping of roads and allotments, and details of proposed reserve development including earthworks, hydrological features, walkways and accessways, landscaping features, landscaping structures, tree planting, revegetation, hard and soft surface treatment, park and road furniture, and playground equipment.

#### **1.8.2.5 Recording of infrastructure – As-built information**

The TA may require the design drawings to be in a certain format, suitable for later addition of as-built information and inclusion in the TA asset map base. In particular, electronic plans will be required in the New Plymouth District. Refer to section 1.8.10 for more information.

### 1.8.3 Design basis for documents submitted for approval

#### 1.8.3.1 Standard design basis

Proposals submitted on a standard design basis shall conform to this Standard.

#### 1.8.3.2 Alternative design basis

Proposals submitted on an alternative design basis may differ from this Standard and shall apply specifically to a particular proposal. TA approval of an alternative design does not confer approval in general by the TA to any design criteria, construction technique or material forming part of the alternative design.

An explanation of the design basis or construction method is to be submitted, for approval in principle. It will be considered on its merits and should be approved provided that the design results in infrastructural development equivalent or superior in performance to that complying with this Standard.

Alternative designs provide flexibility to meet the circumstances and requirements peculiar to the site, or as a means of encouraging innovative design, or to meet the principle of life-cycle costing.

*The National Code of Practice for Utility Operators' Access to Transport Corridors contains additional guidance on planning for new assets in the road reserve.*

#### 1.8.3.3 Life-cycle costing

Life-cycle costing *shall* be used to consider options within a proposal or a proposal as a whole. In undertaking a life-cycle costing, consideration shall be given to the initial costs borne by the developer and the maintenance and replacement costs borne by the future owners or the TA. A reasonable balance shall be maintained between these short-term and long-term costs.

### 1.8.4 Approval of design

1.8.4.1 When it is satisfied that the design meets the requirements of this Standard, or the TA's own provisions, or in the case of an alternative design that the design satisfies the requirements of 1.8.3.2, the TA shall notify the owner that the design has been approved and endorse the plans, specifications, and other documents accordingly. For the purpose of this approval the TA may require the owner to make amendments to any plans, specifications, and other documentation and to submit further or other reports. In considering project design and giving its approval, the TA shall act without undue delay.

*Preliminary approval may be requested prior to the commencing of resource consent process. Any preliminary approval given may be subject to change during the resource consent process. Design approval will not be given until after a resource consent is granted.*

#### 1.8.4.2 Approval before commencing construction

Construction shall not commence on site unless and until:

- (a) Resource consents have been issued, except when no such consents are required; and
- (b) The TA(s) have approved any other consents and the drawings, specifications, and calculations for the specific infrastructure that is required in accordance with 1.8.4.1.

##### *C1.8.4.2*

*S.116 of the Resource Management Act sets out when a resource consent commences. Generally this will be when any appeals against the grant of the consent have been disposed of. Where any appeals are unresolved, approval to commence work will need to be obtained from the Environment Court.*

### 1.8.5 Notification of contracts and phases of construction

1.8.5.1 The developer shall notify the TA, in writing, of the names and addresses of contractors to whom it is proposed to award the contracts, and the nature of the construction in each case.

**1.8.5.2** Unless the TA requires otherwise, the developer shall notify the TA when the following phases of construction are reached and such other phases as the TA may determine to enable inspection to be carried out:

- (a) Commencement of construction;
- (b) Prior to concrete construction;
- (c) Prepared earthworks and subsoil drainage prior to filling;
- (d) Completed earthworks and prepared subgrade - *CBRs (California Bearing Ratio) required, refer to 3.3.3.1;*
- (e) Water, wastewater, and stormwater reticulation prior to backfilling;
- (f) Water and wastewater reticulation during pressure testing;
- (g) Finished basecourse before the commencement of road sealing (*applies in all districts*) with *NDMs (Nuclear Density Meter) and Benkelman Beam tests (applicable in New Plymouth district only);*
- (h) Disinfection of water mains;
- (i) *Prior to any planting;*
- (j) *On completion of planting;*
- (k) *Other specific times as specified by the TA;*
- (l) *Water tracer wire continuity testing.*

At least 24 hours' notice shall be given by the developer. Inspection shall be carried out within 24 hours of notification if possible. Further construction phases shall not proceed until inspection has been made.

**C1.8.5.2**

*TAs may require the appointment of a 'developer's professional advisor' or 'independent qualified person (IQP)' in which case this requirement will be performed by that person.*

## **1.8.6 Supervision of construction**

The level of supervision undertaken in connection with any construction shall be agreed between the TA and the developer, or, if appointed, the developer's professional advisor or the IQP as the case may be, and shall be appropriate to the circumstances considering the size and importance of the project, the complexity of the construction, and the experience and demonstrated skill in quality management of the person undertaking the construction.

*The TA requires completion certificates in the form given in Schedules 1B and 1C. The TA reserves the right to inspect any work at its discretion.* Such certification may be required from the contractors undertaking the construction, or the developer, or the developer's professional advisor (if any). The certificates shall be in the form given in Schedules 1B and 1C.

**C1.8.6**

*An appropriate level of supervision can be selected by reference to the Construction Monitoring Services information published by the Institution of Professional Engineers of New Zealand (IPENZ) and the Association of Consulting Engineers New Zealand (ACENZ).*

## **1.8.7 Connecting to existing services**

**1.8.7.1** Connection of water, wastewater, stormwater, and other services to existing systems will normally be carried out by the appropriate network utility operator at the cost of the developer, except that at the discretion of the network utility operator connections may be made by the owner, or contractor employed by the owner, if appropriately qualified and under the network utility operator's supervision.



**1.8.7.2** The developer shall give the network utility operator 5 working days' notice of intention to connect to existing services. Where required, new services shall be tested and approved by the network utility operator prior to connection.

### **1.8.8 Testing**

Any infrastructure required to be tested by the developer shall be pre-tested and proved satisfactory by the developer before test by the network utility operator is requested.

### **1.8.9 Maintenance**

The developer shall maintain the infrastructure until it is formally taken over by the TA or to a date specified in a bond or consent condition for completion of uncompleted infrastructure. The developer shall not be responsible for damage caused by other activities such as building construction or for fair wear and tear or vandalism caused by public use of the roads that have been taken over by the TA or network authority.

### **1.8.10 Completion documentation**

On completion of all subdivision and land development infrastructure, the developer shall provide the TA with the following:

- (a) The geotechnical reports and as-built plans required by 2.6 of this Standard;
- (b) *As-built plans of all infrastructure showing the information set out in Schedule 1D. As-built plans and data must be provided to NPDC electronically in accordance with the requirements of the New Plymouth District Council As-Built Survey and Data Specification;*
- (c) Evidence that all testing required by this Standard has been carried out and that the test results comply with the requirements of this Standard;
- (d) Evidence that reticulation and plant to be taken over by network utility operators have been installed to their standards and will be taken over, operated and maintained by the network utility operator concerned;
- (e) Completion certificates as per Schedules 1B and 1C;
- (f) Certification by a suitably qualified person where they have recommended a specific design and construction has been undertaken in accordance with that recommendation. The certification shall state that the suitably qualified person supervised the construction and it has been completed in accordance with the recommended design principles;
- (g) Other documentation required by the TA including, but not limited to, operation and maintenance manuals, and warranties for new facilities involving electrical or mechanical plant and asset valuations for all infrastructures to be taken over by the TA.
- (h) *CCTV inspections as per the New Zealand Pipe Inspection Manual. CCTV inspections of new sewer drains requires a minimum of 10mm flowing water to assess gradients and dips.*
- (i) *Asset attributes data, including valuations, shall be provided for assets to be vested in the TA and shall comply with the requirements of the TA.*

### **1.8.11 Approval of uncompleted work**

Where in the opinion of the TA it is assessed as reasonable, and unlikely to materially affect the safe operation of public assets and expectations and interests of the public and directly affected private parties, the TA may approve the deferral of completion of an element of a consented and approved work, subject to satisfactory bonds being arranged.

### **1.8.12 Defects Liability Period**

**1.8.12.1** *Assets to be vested in the TA can be accepted by the TA notwithstanding any Defects Liability Period relating to those assets not having expired. Even if assets have been accepted by the TA, the developer shall remain responsible for the maintenance of the asset during the Defects Liability Period*

*and for the rectification of any defects or the carrying out of any required remedial work during such period with all such work to be carried out to the standard required by the TA. The developer shall not be responsible for fair wear and tear during the Defects Liability Period.*

- 1.8.12.2** *The Defects Liability Period shall be for such a period as the TA shall in its sole discretion determine, taking into account the type, nature and value of the asset.*
- 1.8.12.3** *The Defects Liability Period will commence when construction of the asset has been determined by the TA as being substantially complete. This is the latter of when the asset can function as designed and can be used safely or upon issue of the Section 224 Certificate.*
- 1.8.12.4** *The TA shall be entitled to require the developer to provide a bond in accordance with clause 1.9.2 to ensure compliance with the developer's obligations under this clause.*
- 1.8.12.5** *The developer shall rectify any defects and carry out any required remedial work during the Defects Liability Period within seven days of being made aware of any such defects or the requirement for such remedial work unless otherwise agreed. If the developer fails to rectify any such defects or carry out such remedial work within such seven day period, then the TA may arrange to rectify such defects or carry out such remedial work at the cost to the developer in all respects. The TA shall be entitled to recover any such costs under the terms of any bond entered into by the developer.*
- 1.8.12.6** *The developer shall notify the TA at least 14 days prior to the expiry of the Defects Liability Period and arrange for an inspection of the asset to ensure that the asset is in a condition able to be vested in the TA.*

## **1.9 Bonds and charges**

### **1.9.1 Uncompleted works**

- 1.9.1.1** Bonds to cover uncompleted works, especially where a subdivision or development has been substantially completed, are recognised as an acceptable procedure and *may* be permitted at the discretion of the TA.
- 1.9.1.2** Bonds shall be secured by an appropriate guarantee or shall be in cash and lodged with the TA. Where necessary bonds shall be executed and registered.
- 1.9.1.3** The amount of the bond shall be the estimated value of the uncompleted work plus a margin to cover additional costs estimated to be incurred by the TA in the event of default.
- 1.9.1.4** *The bond shall ensure completion of the work by an agreed date. The developer will advise the Authorised Officer of the TA when the work has been completed. Where it is apparent that the work might not be completed to the required standard by the agreed date, the TA may, at its sole discretion, call in the bond and use the bond amount to complete the work. The developer shall be liable for all costs incurred by the TA in completing the work.*

### **1.9.2 Defects Liability Bond**

- 1.9.2.1** *The TA shall be entitled to require the developer to enter into a Defects Liability Bond to secure the obligations of the developer during the Defects Liability Period.*
- 1.9.2.2** *The bond amount shall be based on the capital value of the asset as follows:*
- 5% of the first \$200,000; plus
  - 2.5% of any amount over \$200,000
- to a maximum bond amount of \$200,000.*

**1.9.2.3** *The TA may require the bond amount to be in cash or may require an approved guarantor to guarantee the obligations of the developer pursuant to the Defects Liability Bond.*

**1.9.2.4** *The terms of the Defects Liability Bond shall be otherwise upon such terms as the TA shall require, taking into account the type, nature and value of the asset and the Defects Liability Period.*

**1.10 Fees and Charges**

*All activities, approvals, connections or the like required to comply with these standards shall be subject to fees and charges as set out in Council's Fees and Charges Policy where applicable.*

DRAFT FOR CONSULTATION

**SCHEDULE 1A  
DESIGN CERTIFICATE – LAND DEVELOPMENT/SUBDIVISION**

ISSUED BY: .....  
(Approved certifier firm/suitably qualified design professional)

TO: .....  
(Developer/owner)

TO BE SUPPLIED TO: .....  
(Territorial authority)

FOR: .....  
(Description of land development/subdivision)

AT: .....  
.....  
(Address)

..... has been engaged by .....  
(Consultant/designer) (Developer/owner)

to provide..... services for the land development and/or subdivision described above.

I ..... have the qualifications and experience relevant to this project as set out herein and have designed the land development/subdivision and confirm that the design is to current engineering practice, and that I believe on reasonable grounds that it satisfies all relevant resource consent conditions, all relevant ..... (insert name of authority) requirements and applicable codes and standards.

I / My practice holds professional indemnity insurance to the amount of \$..... and includes run-off cover.

..... Date .....  
(Signature of approved certifier on behalf of the approved certifier firm)

.....  
(Name, title, and professional qualifications)

NOTE – This statement shall only be relied upon by the territorial authority named above. Liability under this statement accrues to the approved certifier firm only. The total maximum amount of damages payable arising from this statement and all other statements provided to the territorial authority on this land development/subdivision, whether in contract, tort, or otherwise (including negligence), is limited to the sum of \$..... (insert)

Copyright waived

**SCHEDULE 1B  
CONTRACTOR'S CERTIFICATE UPON COMPLETION OF LAND  
DEVELOPMENT/SUBDIVISION**

ISSUED BY: .....  
(Contractor)

TO: .....  
(Principal)

TO BE SUPPLIED TO: .....  
(Territorial authority)

FOR: .....  
(Description of land development/subdivision)

AT: .....  
.....  
(address)

..... has contracted to .....  
(Contractor) (Principal)

to carry out and complete certain land development and/or subdivision construction in accordance with a contract, titled Contract No. .... for ..... ('the contract').

I ..... a duly authorised representative of .....  
(Duly authorised agent) (Contractor)

hereby certify that ..... has carried out and completed  
(Contractor)

the construction, other than those outstanding works listed below, in accordance with the contract and in accordance with approved engineering drawings and specifications.

..... Date .....  
(Signature of authorised agent on behalf of)

.....  
(Contractor)

.....  
(Address)

Outstanding works  
.....  
.....  
.....

Copyright waived

**SCHEDULE 1C  
CERTIFICATION UPON COMPLETION OF LAND  
DEVELOPMENT/SUBDIVISION**

ISSUED BY: .....  
(Approved certifier firm)

TO: .....  
(Developer/owner)

TO BE SUPPLIED TO: .....  
(Territorial authority)

FOR: .....  
(Description of land development/subdivision)

AT: .....  
.....  
(Address)

..... has been engaged by .....  
(Consultant/designer) (Developer/owner)

to provide construction observation review and certification services for the above subdivision which is described in the specification and shown on the drawings numbered

..... approved by .....  
(Territorial authority)

I have sighted the ..... consent and conditions of  
subdivision  
(Territorial authority)

and the approved specification and drawings.

On the basis of periodic reviews of the construction and information supplied by the contractor in the course of the construction, I believe on reasonable grounds that the infrastructure other than those outstanding works listed below, is complete and has been constructed in accordance with:

- (a) The approved engineering drawings and specifications and any approved amendments;
- (b) The Council's Engineering Standards; and
- (c) The manufacturer's instructions

..... Date .....  
(Signature of approved certifier on behalf of the approved certifier firm)

.....  
(Name, title, and professional qualifications)

NOTE – This statement shall only be relied upon by the territorial authority named above. Liability under this statement accrues to the approved certifier firm only. The total maximum amount of damages payable arising from this statement and all other statements provided to the territorial authority in relation to this land development/ subdivision, whether in contract, tort, or otherwise (including negligence), is limited to the sum of \$..... (insert).

Outstanding works  
.....

Copyright waived

## SCHEDULE 1D AS-BUILT PLANS

Information given on as-built drawings, shall be submitted electronically and shall include, but not be limited to:

- (a) Stormwater and wastewater reticulation – including the coordinated positions of manholes, manhole inverts, inverts of pipes and lid levels, measurements to house connections, and laterals and their length and position. Positions of connections and laterals shall be both coordinated and referenced to adjacent manhole lids and boundary pegs. All levels shall be in terms of datum approved by the TA;
- (b) Stormwater management devices – as-built plans for low impact stormwater management devices and non-reticulated components;
- (c) Flood and secondary flow information, flood water levels and the extent of any overland secondary flows shall be shown where these have been obtained or derived during the design;
- (d) Water reticulation – including the position of mains, location of hydrants, valves, tees, reducers, connections, tobies, water meters, and specials. All features shall be accurately dimensioned, coordinated, and referenced so that they can be accurately relocated in the field;
- (e) Ducts – measurements to ducts installed by the developer for utilities;
- (f) Labelling of pipes and ducts to cover diameter, pipe material and class, year laid, jointing type;
- (g) Road names where available – as approved by the TA;
- (h) Coordinates and levels of all utility surface features to be taken over by the TA, including tobies, and water meters;
- (i) The coordinates of at least two points on each plan in terms of an appropriate geodetic or cadastral datum and the origin of the plan level datum;
- (j) Geotechnical completion report and as-built drawings as detailed in 2.6.1 and 2.6.2 of NZS 4404:2010. As-built surface contours covering all areas of disturbed and cut/fill ground;
- (k) Road construction, including location, structural details, and details of road marking, signals, lighting, and signs, landscape features, seating, and other amenities and features;
- (l) Road pavement and surfacing information;
- (m) Landscape features, seating, and other amenities and features;
- (n) *Completed schedule of land and assets to vest in Council;*
- (o) *Lighting/electrical cable.*

Copyright waived

## 2 EARTHWORKS AND GEOTECHNICAL REQUIREMENTS

### 2.1 Scope

This section sets out requirements for the assessment of land stability and the design and control of earthworks to ensure a suitable platform for the construction of buildings, roads, and other structures. A low impact design approach is preferred. Geotechnical assessment shall be undertaken by a geo-professional defined in 1.2.2 of this Standard where:

- (a) The assessment of land stability requires specialist expertise;
- (b) The construction of earthworks associated with any development requires initial planning and design to ensure that banks and batters remain stable and that fill material is placed in such a way that it remains stable and can support the future loads imposed on it;
- (c) There is historical fill which has not been undertaken in accordance with any Standard or where natural slopes, banks, or batters are involved;
- (d) The assessment of ground for the foundations of buildings, roads, services, and other infrastructure requires specialist expertise as weak ground may require special design;
- (e) The wide range of soil types, physical conditions, and environmental factors applying in different areas make it difficult to specify precise or prescriptive requirements for land stability assessment or earthworks.

In setting design, construction requirements, or development limitations the designer shall take account of all relevant standards and TA requirements.

*C2.1  
NZS 4431 is applicable to the construction of earth fills for residential development including residential roading*

### 2.2 General

#### 2.2.1 Objective

The objective of this section is to set out some, but not necessarily all of the matters which need to be considered in planning and constructing a land development project. The aim is to provide information for professionals involved in designing and constructing a land development project and to require geotechnical expertise in projects where land stability could be an issue or where earthworks other than of a minor nature will occur.

The geo-professional needs to be involved in the choice of final land form. This decision depends on many factors which may be specific to the development. These include the relationship with surrounding landscapes, the size of the development, the proposed and existing roading patterns, the preservation of natural features, wāhi tapu, and other historic and archaeological sites, the land stability and underlying structural geology, the function and purpose of the development and the potential for flooding, and erosion and other natural hazards and events including earthquakes. The aim is to also give guidance on the identification of and assessment of the order of importance of the above factors which will vary from project to project.

#### 2.2.2 Referenced documents

A selection of useful guidance material on geotechnical and geomechanical issues in land development is set out in Referenced Documents. Related Documents lists additional material that may be useful.



### 2.2.3 Territorial authorities' requirements

The TA may require an assessment of land stability to meet the provisions of the Resource Management Act and Building Act. The TA requires and relies on the assessment made by the geo-professional.

Special requirements apply when land is subject to erosion, avulsion, alluvium, falling debris, subsidence, slippage, rotation, creep, or inundation from any source. In such situations reference needs to be made to s. 106 of the Resource Management Act and, for subsequent building work, s. 71 of the Building Act.

Advice should be sought from the regional council for earthworks and consent requirements.

The methods used and investigations undertaken are defined by the TA and the geo-professional.

This Standard does not set those requirements or set standards for assessing geotechnical risk.

### 2.2.4 Geotechnical requirements

Where any proposed development involves the assessment of slope stability or the detailed evaluation of the suitability of natural ground for the foundations of buildings, roading, and other structures, or the carrying out of bulk earthworks, then a geo-professional shall be appointed by the developer to carry out the following functions:

- (a) Check regional and district plans, records, and requirements prior to commencement of geotechnical assessment;
- (b) Prior to the detailed planning of any development, to undertake a site inspection and such investigations of subsurface conditions as may be required, and to identify geotechnical hazards affecting the land, including any special conditions that may affect the design of any pipelines, underground structures, or other utility services;
- (c) Before construction commences, to review the drawings and specifications defining any earthworks or other construction and to submit a written report to the TA on the foundation and stability aspects of the project;
- (d) Before and during construction, to determine the extent of further geo-professional services required (including geological investigation);
- (e) Any work necessary to manage the risk of geotechnical instability during the construction process;
- (f) Before and during construction, to determine the methods, location, and frequency of construction control tests to be carried out, determine the reliability of the testing, and to evaluate the significance of test results and field inspection reports in assessing the quality of the finished work;
- (g) During construction, to undertake regular inspection consistent with the extent and geotechnical issues associated with the project;
- (h) On completion, to submit a written report to the TA attesting to the compliance of the earthworks with the specifications and to the suitability of the development for its proposed use including natural ground within the development area. Where NZS 4431 is applicable, the reporting requirements of that Standard shall be used as a minimum requirement.

## 2.3 Design

### 2.3.1 Design factors

The design process shall include, but not be limited to:

- (a) Preliminary site evaluation;
- (b) Identification of special features to be retained/protected;

- (c) Low impact design considerations;
- (d) Selection of the choice of landform;
- (e) Stability assessment;
- (f) Assessment of special soil types where applicable;
- (g) Setting of compaction standards for fill material;
- (h) Erosion, sediment, and dust control;
- (i) Seismic considerations;
- (j) Geothermal issues where applicable.

### 2.3.2 Preliminary site evaluation

During the preliminary site evaluation phase the developer's professional advisor shall engage a geotechnical professional at an early stage to undertake a preliminary site evaluation and prepare a geotechnical assessment report where there is doubt about the stability or suitability of the ground for the proposed development, or there are any TA or local practice requirements for geotechnical involvement in the project.

In cases where more than a visual appraisal is deemed to be required, particular attention will need to be given to the following matters, as appropriate, which should normally be considered prior to preparing a proposal for development:

- (a) Low impact design factors:  
The preliminary site evaluation needs to take into account low impact design factors. These include consideration of maintaining and improving natural waterway features and optimising waterway crossing locations. Protection of well-drained soils and natural soakage areas also need to be taken into account. *LID is synonymous with Water Sensitive Design in the New Plymouth District.*
- (b) Drainage:  
Identify the existing natural drainage pattern of any area and locate any natural springs or seepage. Where any overland flow paths or natural surface or subsurface drainage paths are interfered with or altered by earthworks, then appropriate measures should be taken to ensure that adequate alternative drainage facilities are provided to ensure there is no increase in flood hazard risk to the site or adjoining properties.
- (c) Slope stability:  
Some natural slopes exist in a state of only marginal stability and relatively minor disturbance such as trenching, excavation for streets or building platforms, removal of scrub and vegetation, or the erection of buildings, can lead to failure. Signs of instability include cracked or hummocky surfaces, crescent-shaped depressions, crooked fences, trees or power poles leaning uphill or downhill, uneven surfaces, swamps or wet ground in elevated positions, plants such as rushes growing down a slope, and water seeping from the ground. In addition, a simple desktop study of aerial photographs may show indications of historic failures as well as faulting, resulting in linear ground features. Refer to BRANZ Study Report 004, Crawford and Millar 1998, or the New Zealand Geotechnical Society publications. Field description of soil and rock and Geotechnical issues in land development. For a sample checklist for geotechnical assessments refer to Crawford and Millar 1998. Existing or potential surface creep effects also need to be investigated and reported upon.
- (d) Foundation stability:  
A study of the general topography of the site and its surroundings may indicate areas which have previously been built up as a result of natural ground movement or by the deliberate placing of fill material. Unless such fill has been placed and compacted under proper control, instability or long-term differential settlement could occur causing damage to superimposed structures, roads, services, or other structures.

- (e) Stream instability:  
There is a potential for instability through changes to the current ground conditions, such as stream erosion.
- (f) Local conditions:  
A wide range of soil types exists throughout New Zealand which may need special consideration. Expansive soils, volcanic soils, soft alluvial sediments, and compressible soils are examples of these. Liquefaction of saturated non-cohesive soils should also be considered. The TA may have information on the soil types in its area, including potentially contaminated land.
- (g) Peer review:  
Where risk for the land prior to development is assessed as being medium to very high risk, a peer review of the geotechnical assessment for the proposed development may be required and this would need to be carried out by an independent geo-professional. (For guidance see NZ Geomechanics News (Crawford and Millar) for risk classification and (Cook et al) for peer review.)

#### C2.3.2

*The preliminary evaluation should be carried out in the context of the total surroundings of the site, and should not be influenced by details of land tenure, territorial, or other boundary considerations. Where the preliminary evaluation discloses the potential for slope instability, other geotechnical or geological hazards, or the need for major foundations or for earthworks, the geo-professional should be involved at an early stage in the planning of the development.*

### 2.3.3 Landform selection

The final choice of landform shall represent the most desirable compromise between the development requirements and the preservation of natural features and the natural character and landscape amenity values of the site including the retention of natural watercourses. Landform selection needs to take into account low impact design principles including retention of existing landforms and natural features where possible, and avoiding earthworks where there are existing habitats of indigenous species, wetlands, or areas of high natural character. The design shall take into account the following factors in making the selection of the final choice of the landform:

- (a) The choice of a suitable landform may be specific to a particular site. An earthworks approach that respects and reflects the natural topography of the site is preferred. Considerations for carrying out earthworks include:
  - (i) The minimisation of the risk of damage to property occurring through ground movement in the form of slips, subsidence, creep, erosion, or settlement
  - (ii) The minimisation of the risk of damage to property occurring through flooding, or surface water run-off
  - (iii) The development of a more desirable roading pattern with improved accessibility to and within the site and the creation of a better sense of orientation and identity for the area as a whole
  - (iv) The efficiency of overall land utilisation including the quality of individual sites and amenity areas around buildings, the economics of providing engineering services, and the standard of roading and on-site vehicular access
  - (v) The need to create suitably graded areas for playing fields and other community facilities, and
  - (vi) The enhancement of the general environmental character of the area;
- (b) The general nature and shape of the ground including:
  - (i) The geological nature and distribution of soils and rock
  - (ii) Existing and proposed drainage conditions, and the likely effects on groundwater
  - (iii) Previous history of ground movements in similar soils in the area

- (iv) Performance of comparable cuts and fills (if any) in adjacent areas, and
  - (v) Air photography and other sources of information which should be reviewed and incorporated into any slope stability assessment;
- (c) Soil data as applicable for areas which:
- (i) Are intended to form in situ bases for fills
  - (ii) Are intended to yield material for the construction of fills
  - (iii) Are intended to be exposed as permanent batters, and
  - (iv) Are to remain as permanent slopes or cut areas;
- (d) Borings, probings, or open cuts as necessary to:
- (i) Classify the soil strata by field and visual methods
  - (ii) Evaluate the likely extent and variation in depths of the principal soil types, and
  - (iii) Establish the natural groundwater levels;
- (e) Soil information required for:
- (i) Further sampling and testing which may be required on representative soil types
  - (ii) Relating subsequent soil test properties to relevant strata over the site
  - (iii) Assessment and design for slope stability
  - (iv) Assessment and design for foundations suitable for the finished site, and
  - (v) Assessment and design for road subgrades

The test data appropriate in different areas should be determined by the geo-professional.

#### **2.3.4 Stability criteria**

In making an assessment of the stability of slopes and earth fills, the geo-professional shall use accepted criteria and analysis methods. Stability criteria applicable to land development in New Zealand are published or recommended by the New Zealand Geotechnical Society (see Referenced Documents).

#### **2.3.5 Special soil types**

If special soil types are known to exist in a locality or are identified, then a geo-professional shall be engaged to advise on appropriate measures for incorporation of these soils into a development. Special soil types include, but are not limited to:

- (a) Soils with high shrinkage and expansion;
- (b) Compressible soils;
- (c) Volcanic soils;
- (d) Soils subject to liquefaction;
- (e) Soils prone to dispersion (such as loess).

##### **C2.3.5**

*The geo-professional should refer to the TA for hazard maps or information on special soil types in the locality if unfamiliar with the area.*

### 2.3.6 Compaction standards for fill material

The standard of compaction and method of determination shall be as set out in NZS 4431. Where NZS 4431 is not applicable, the methods and standards of compaction shall be specified by the ge-professional.

#### C2.3.6

*Commercial and industrial developments often have specialised requirements for fill materials and compaction. In these cases the requirements of NZS 4431 may not be applicable. The ge-professional should set the fill standards and procedures for these developments.*

### 2.3.7 Erosion, sediment, and dust control

#### 2.3.7.1 Minimisation of effects

Earthworks shall be designed and constructed in such a way as to minimise soil erosion and sediment discharge. Where necessary, permanent provision shall be made to control erosion and sediment discharge from the area of the earthworks.

Generation of dust during and after the earthworks operation shall be considered during the planning and design phase. If necessary, specific measures shall be incorporated to control dust.

#### C2.3.7.1

*Most TAs have requirements for erosion, sediment, and dust control or these will be set in resource consents for the project. Such conditions should be referred to and taken into account in the early stages of planning a project.*

#### 2.3.7.2 Protection measures

Where surface water could cause batter erosion or internal instability through infiltration into the soil, open interceptor drains shall be constructed in permanent materials, and benches in batter faces should be sloped back and graded longitudinally and transversely to reduce spillage of stormwater over the batter.

Water from stormwater systems shall be prevented from flowing into fill or into natural ground near the toe or sides of the fill.

No stormwater or wastewater soakage systems shall be constructed in fill or natural ground which could impair the stability of the ground.

Protection measures shall include the following as appropriate:

- (a) Erosion control mechanisms:
  - (i) Temporary drains to be constructed at the toe of steep slopes to intercept surface run-off and to lead away for treatment where required before discharge to a stable watercourse or pipe stormwater system
  - (ii) Surface water to be diverted away from or prevented from discharging over batter faces and other areas of bare earth by bunds formed to intercept surface run-off and treated where required prior to discharge through stable channels or pipes, preferably into stable watercourses or piped stormwater systems
  - (iii) The upper surface of fills to be shaped and compacted with rubber-tyred or smooth-wheeled plant when rain is impending, or when the site is to be left unattended to minimise water infiltration
  - (iv) The completed battered surfaces of fills to be topsoiled and vegetated, or otherwise resurfaced to reduce run-off velocities
  - (v) Control of erosion and sediment discharge may require planting, environmental matting, hydroseeding, drainage channels, or similar measures at an early stage in the earthworks construction phase

- (vi) Dust control may require frequent watering during construction along with establishment of the permanent surface at an early stage in the construction phase;
- (b) Sediment management devices:
  - (i) The surfaces of fills and cuts to be graded to prevent ponding
  - (ii) Sediment traps and retention ponds to be constructed where they are necessary. These should be cleaned out, as required, to ensure that adequate sediment storage is maintained, with appropriate plans for decommissioning
  - (iii) Temporary barriers or silt fences using silt control geotextiles, to be used to reduce flow velocities and to trap sediment
  - (iv) Sections of natural ground to be left unstripped to act as grass (or other vegetation) filters for run-off from adjacent areas.

### **2.3.8 Seismic considerations**

The geo-professional shall consider the seismic effects on earth fills, slopes, and liquefiable ground and shall take these into account in design and construction of any development in accordance with the scale of the development.

## **2.4 Approval of proposed works**

The approval process for land development and subdivision design and construction shall be in accordance with section 1 of this Standard. Land stability assessments and the design and control of earthworks require approval from the TAs.

## **2.5 Construction**

Earthworks shall be carried out to the standards detailed in the approved specifications and drawings, and any requirements in a regional or district plan or consent issued by the TA.

The construction control testing shall be carried out by a testing laboratory or competent person under the control of the geo-professional, and to the recognised testing standards as deemed appropriate.

The testing laboratory shall have recognised registration or quality assurance qualifications.

## **2.6 Final documentation**

### **2.6.1 Geotechnical completion report**

For all developments where a geo-professional is engaged the geo-professional shall submit a geotechnical completion report to the developer and the TA accompanied by a statement of professional opinion as set out in Schedule 2A. The geotechnical report shall identify any specific design requirements which would necessitate the building design deviating from NZS 3604.

The expected level of site movement from reactive soil (expansive soils) under AS 2870:1996 shall be identified by their respective class and included in the geotechnical completion report. The soil properties used in determining the class are to be recorded in the report. The site subsoil class to the provisions of NZS 1170.5 section 3 and NZS 1170.5 Supp 1 C3.1.3 shall be identified in the geotechnical completion report.

The report shall describe the extent of inspection, revisit and review all inferences and assumptions made during the investigation, assess the results of testing and state the geo-professional's professional opinion on the compliance of the development with the standards set by the geo-professional. The report shall also include all geotechnical reports prepared for the development.

Documentation on the testing of the soils for compaction shall be included in the geotechnical completion report. This documentation should clearly show the areas in which compaction met the required standards, as well as any areas requiring retesting, and areas which did not meet the standards.

For developments where there are no earthworks the geotechnical completion report will comprise the geotechnical assessment report. For large or more complex developments where there may have been several stages of geotechnical reporting, all prior reports covering the subject area of land under certification shall be included in the geotechnical completion report. The geotechnical completion report shall identify areas that provide good ground as defined in NZS 3604. Those areas that require specific design for stability and foundation design shall also be noted.

### **2.6.2 As-built drawings for earthworks and subsoil drains**

Where earthworks have occurred, an as-built plan shall be prepared showing finished contours. The plans shall also show original contours where earthworks have occurred to illustrate the extent and depth of cuts and fills. Alternative methods of representing earthwork depths may be acceptable including plans showing lines joining all points of equal depth of cut and fill at appropriate vertical intervals. The as-built plans shall also record the position, type, and size of all subsoil drains and their outlets, and show any areas of fill or natural ground which the geo-professional considers do not comply with this Standard or areas where the standards have been varied from the original construction specification.

These plans shall be made available to the TA and the developer in conjunction with the geotechnical completion report.

DRAFT FOR CONSULTATION

**SCHEDULE 2A  
STATEMENT OF PROFESSIONAL OPINION ON SUITABILITY OF LAND FOR  
BUILDING CONSTRUCTION**

Development .....

Developer .....

Location .....

I ..... of .....  
*(Full name)* *(Name and address of firm)*

Hereby confirm that:

1. I am a geo-professional as defined in clause 1.2.2 of NZS 4404:2010 and was retained by the developer as the geo-professional on the above development.
2. The extent of my preliminary investigations are described in my Report(s) number ....., dated ....., and the conclusions and recommendations of that/those document(s) have been re-evaluated in the preparation of this report. The extent of my inspections during construction, and the results of all tests and/or re-evaluations carried out are as described in my geotechnical completion report dated .....
3. In my professional opinion, not to be construed as a guarantee, I consider that (delete as appropriate):
  - (a) The earth fills shown on the attached Plan No..... have been placed in compliance with the requirements of the ..... Council and my specification.
  - (b) The completed works take into account land slope and foundation stability considerations, subject to the appended foundation recommendations and earthworks restrictions, (which should be read in conjunction with the appended final site contour plan).
  - (c) Subject to 3(a) and 3(b) of this Schedule, the original ground not affected by filling is suitable for the erection of buildings designed according to NZS 3604 provided that:
    - (i) .....
    - (ii) .....
  - (d) Subject to 3(a) and 3(b) of this Schedule, the filled ground is suitable for the erection of buildings designed according to NZS 3604 provided that:
    - (i) .....
    - (ii) .....
  - (e) The original ground not affected by filling and the filled ground are not subject to erosion, subsidence, or slippage in accordance with the provisions of section 106 of the Resource Management Act 1991 provided that:
    - (i) .....
    - (ii) .....

NOTE – These subclauses may be deleted or added to as appropriate, to include such considerations as expansive soils where excluded from NZS 3604, and site seismic characteristics as covered in clause 3.1.3 of NZS 1170.5.



4. This professional opinion is furnished to the TA and the developer for their purposes alone on the express condition that it will not be relied upon by any other person and does not remove the necessity for the normal inspection of foundation conditions at the time of erection of any building.
5. This certificate shall be read in conjunction with my geotechnical report referred to in clause 2 above and shall not be copied or reproduced except in conjunction with the full geotechnical completion report.

Signed ..... Date .....

.....

.....

.....

*(Name, title, and professional qualifications)*

Copyright waived

DRAFT FOR CONSULTATION

## **3 ROADS**

### **3.1 Scope**

This section sets out requirements for the design and construction of roads for land development and subdivision. Section 3 provides engineering design and construction solutions for most situations.

### **3.2 General**

#### **3.2.1 Objective**

The objective is to provide roads that are safe for all road users and designed to the context of their environment. Roads shall be capable of carrying all utility services underground, provide for the management of stormwater, and contribute to quality urban design.

#### **3.2.2 Related Standards and guidelines**

A selection of currently available documents which provide an appropriate basis for road design is set out in Referenced Documents. Related Documents lists additional material that may be useful. These are not exclusive. Other Standards, guidelines, and design responses may be used where appropriate and accepted by the TA.

#### **3.2.3 Road purpose**

Roads serve a number of purposes that enhance quality of life in neighbourhoods, towns, and cities; improve opportunities for business in commercial areas; and meet a range of local, regional, and national goals for access, mobility, and land use.

Roads serve the following functions:

- (a) A place for access and interaction, including:
  - (i) Providing for human interaction
  - (ii) Facilitating commerce and business
  - (iii) Enabling access to buildings, lots, and public spaces
  - (iv) Parking;
- (b) A link for connection and movement of people and goods including the following user groups:
  - (i) Pedestrians
  - (ii) Cyclists
  - (iii) Public transport
  - (iv) Freight and goods vehicles
  - (v) Private motor vehicles
  - (vi) Other modes which are not vehicles;
- (c) A corridor for utility and amenity infrastructure, including:
  - (i) Stormwater treatment and conveyance
  - (ii) Road lighting
  - (iii) Landscaping and street furniture
  - (iv) Utility services
  - (v) Signals, signs, and markings
  - (vi) Safety, convenience, and crime prevention.

### 3.2.4 Deleted (Place and link context)

**Table 3.1 – Deleted (Land use and area type matrix describing typical place & transport context)**

#### C3.2.4.2

*Arterial roads and motorways are not included in this Standard. These roads are subject to specific design standards to be agreed with the road controlling authority to ensure through movement connectivity associated with the broader sector in which such roading is located. The following descriptions are included for information:*

- (a) *Minor arterial road: A road that provides access between connector/collector and major arterial roads. Minor arterial roads have a dominant through vehicular movement and carry the major public transport routes. Access to property may be restricted and rear servicing facilities may be required. Urban traffic volumes are typically 8,000 vpd to 20,000 vpd and rural from 1,000 to 5,000 vpd with a higher proportion of heavy vehicles. Typical urban operating speeds are 40 to 60 km/h and rural 80 to 100 km/h.*
- (b) *Major arterial road: A road that provides interconnections between major sectors of a large area linked with external areas and distributes traffic from major intercity links. Access is generally at grade but may be limited. Urban traffic volumes are typically greater than 20,000 vpd and rural 5,000 vpd with a significant number of heavy vehicles. Typical urban operating speeds are 50 to 70 km/h and rural 80 to 100 km/h.*
- (c) *Motorway: Motorways have the highest link function and have no frontage access. Typical operating speed is 100 km/h.*

*Designers are encouraged to read the One Network Road Classification System in conjunction with this standard to ensure compatibility and consistency.*

### 3.2.5 Network connectivity

Well-connected networks (roads and other links) are achieved with smaller block sizes and regular connections. Network connectivity shall be designed to achieve:

- (a) Shorter travel distances;
- (b) An increased number of alternative routes for all types of users;
- (c) Increased opportunity for interaction;
- (d) Improved access to public transport, cycling and walking networks, and access to destinations.

Development design shall ensure connectivity to properties and roads that have been developed, or that have the potential to be developed in the future. The design process should ensure the following maximum walking distances from a lot to a connector/collector or arterial road:

- (a) Rural: No maximum distance. The design should maximise future connectivity to a suburban network;
- (b) Urban: 300 m;
- (c) Centre: 200 m.

Where factors, such as topography or barriers, limit the ability to achieve the network connectivity standard, the designer shall optimise network connectivity and access to the maximum extent practical. The designer shall maximise connectivity to existing development.

### 3.2.6 Design and access statement

A design and access statement shall be submitted with the application for design approval. The statement shall cover all relevant aspects of 3.2 and 3.3 of this Standard and specifically address:

- (a) Road dimensions and layout;

- (b) Link and place functions;
- (c) Connectivity;
- (d) How target operating speeds will be achieved;
- (e) How LID principles have been considered for stormwater run-off from the roads. *LID is considered to be synonymous with Water Sensitive Design within the New Plymouth District.*

In addition a design and access statement shall evaluate the effects of the proposed development at its ultimate extent (and staged, where applicable) on the surrounding communities and transportation network.

#### **C3.2.6**

*Design and access statements allow the basis of the road design to be independently reviewed, and should be sufficient to illustrate the reasons for the design selections.*

### **3.2.7 Road safety audit**

Proposals that provide for new roads to vest in the TA should be subject to the NZTA *Road safety audit procedures for projects* unless the TA decides that audits are not required at any or all of the stages. The developer's professional advisor may recommend that audits are not required at any or all of the stages and complete an 'exemption declaration' as described in the procedures and submit it as part of the application process to be considered by the TA. The 'exemption declaration' shall be prepared by a suitably qualified road safety auditor.

Safety audits should cover all road users, including the needs of pedestrians, cyclists, and disabled/elderly users. Where appropriate, the requirements of these groups may demand specific audit procedures.

## **3.3 Design**

### **3.3.1 Design requirements**

Table 3.2 should be used as the basis for road design. However, road types E11 and H1 only apply within the New Plymouth District. Road designers are not restricted to the road designs illustrated. The purpose of the diagrams is to demonstrate road designs that allocate sufficient space for the various elements of each road type.

Road widths shall be selected to ensure that adequate movement lanes, footpaths, berms, and batters can be provided to retain amenity values (including landscaping) and enable utility services to be provided safely and in economically accessible locations. Road widths shall be planned to cope with estimated long-term community needs even though construction may be carried out only to shorter-term requirements.

Alternative carriageway widths may be adopted to suit particular design considerations. These shall be subject to specific design consideration and approval by the TA. Such cross sections may include landscaped features, painted median facilities, or variations to parking provision. Carriageways should avoid widths of 5.7 m to 7.2 m and 7.5 m to 9.0 m where these widths may cause confusion between movement and parking functions.

**C3.3.1**

*In the case of a rear access lane, the concept relies heavily on minimal garage setback from the lane frontage. Rear access lanes are required to provide for manoeuvring for access to/from garages. Where the garages are located on or close to the lane edge the manoeuvring requirement may necessitate a wider lane dimension or increased setback. In this sense, a key function of the lane is to operate akin to an aisle within a car parking area and needs to be designed accordingly. A single lane sealed width with widening at the garage locations for turning is the minimum requirement. Sealing the entire lane increases opportunities for the lane to be used in a social sense. It is therefore desirable for the entire lane to be sealed, although a narrow berm for services may be necessary.*

*There are three bi-directional carriageway types. These are:*

- (a) A width in the range 5.5 m – 5.7 m providing for ability to park on one side of the road and one through lane, or alternatively two through lanes. This is often not defined at the engineering stage and is instead left to road users to choose. This type of road is provided for in the standard and is typically appropriate for shorter streets of up to approximately 250 m, to assist with achieving a slower operating speed.*
- (b) A width in the range of 7.2 m – 7.5 m providing an ability for either two parked cars and one through movement, or one parked car and two through movements. This is typically not defined through the provision of parking bays although it may be. There may be cases in lower parking demand situations where this width is achieved with varied pinch points to provide a road with two through lanes and a parking bay.*
- (c) A width in the range 9.0 m – 9.5 m providing ability for two through lanes and two parking lanes. Depending on parking demand this can either be achieved with landscaping such as tree boxes/pits and recessed parking, or by maintaining full flexibility with a straight edge.*

The designer shall consider the environment, purpose, and function of the road being designed. In developing a design cross section the designer shall consider the relationships between speed, parking and its frequency, and the shared or recessed nature of parking in the movement lanes. In general a wider standard total carriageway cross section can be developed where parking is shared in the movement lane, however if this is not a frequent occurrence then the outcome will be an unnecessarily wide road and the target speed outcome will not be achieved without other managed intervention. Where parking is less frequent, consideration shall be given to narrowing the travelling carriageway and recessing the parking or to introducing landscaping into the carriageway to reduce the appearance of apparent formed width. Where the designer proposes to develop a shared street design that varies from that shown in Table 3.2, a full description and assessment of the frequency and extent of interactions of this nature shall be described in the design and access statement.

Roads shall be designed to account for stormwater and keep potential groundwater below structural pavement layers. On rural roads, side drains or swales shall be provided to carry stormwater and keep potential groundwater below structural pavement layers. All roads, including footpaths and cycleways, shall be adequately drained in accordance with good engineering practice. Roads also have the potential to provide stormwater ponding and overland flow paths when the primary system is overloaded (see 4.3.4.2).

In soils of adequate permeability and favourable topography, the use of low impact design soakage systems and devices shall be considered to provide benefits of attenuating peak flows and improving run-off quality. For detailed design criteria for soakage systems and devices see 3.3.19.5, 4.3.7.6, and 4.3.7.9.

Any design should be coordinated with the relevant landscape design requirements covered in section 7.

Table 3.2 should be read in conjunction with 3.3.1.1 to 3.3.1.10.

- 3.3.1.1** A movement lane may include a single lane operating in a one-way configuration or in two directions. Normal camber is 3%. Maximum super elevation is 6%.

- 3.3.1.2** No more than one movement lane in each direction is typical. Streets in urban areas and centres may include a single movement lane operating as a one-way street.
- 3.3.1.3** Each parking/passing area should be a minimum 2.2 x 6 m, and a loading area a minimum 2.5 x 12 m, each with appropriate entry and departure tapers outside of the movement lane. Provision is to be made on one lane two way carriageways for passing every 50 m and at corners.
- 3.3.1.4** Where not shown in the table cyclists shall be provided with separate movement lanes if identified in a local or regional cycle network.
- 3.3.1.5** Side and rear access should not be the primary access.
- 3.3.1.6** Shoulder widths on rural roads need to be assessed for each project based on the speed environment of the area and terrain. For high speed environments where high non-motorised use is expected, shoulder widths may need to be increased to optimise overall road safety.
- 3.3.1.7** Minimum gradient is 0.4%. Maximum gradients shall be as indicated in Table 3.2. Steeper gradients may be acceptable for shorter lengths of road in hilly country or low overall speed environments subject to TA approval.
- 3.3.1.8** In some circumstances an increased overall road reserve may be necessary for utilities provision or increased amenity, landscape or urban design element. Specific design shall be undertaken and agreed with the territorial authority where road reserves are to be reduced. In other circumstances, reserve widths may be reduced if a one way road, or development is on one side of the road.
- 3.3.1.9** All carriageways shall be sealed for the first 10 m from the intersection with another road.
- 3.3.1.10** Where the gradient of a public road is steeper than 12.5%, a resolution of the TA or a District Plan allowance is required. Refer to s. 329 (road gradients) of the Local Government Act 1974.

### **3.3.2 Road geometric design**

#### **3.3.2.1 Design parameters**

Roads shall be designed to accepted standards generally satisfied by Table 3.2 of this Standard *and* the relevant Austroads guides, and guides listed in Referenced Documents and Related Documents for other facilities.

*For all new subdivisions, the cut and fill batters must be outside the road reserve boundary.*

*In addition to Table 3.2, Figure 3.0b shows a typical cross section of an urban berm indicating road infrastructure, services and utilities.*

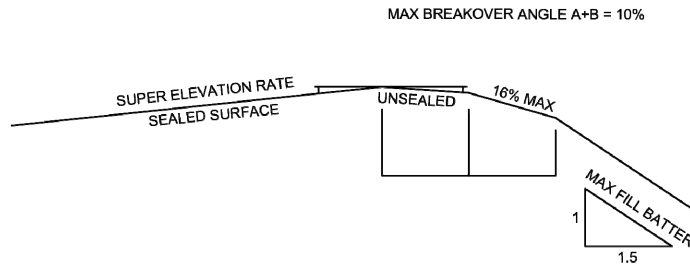

**DETAIL OF OUTSIDE SHOULDER IN SUPERELEVATION**

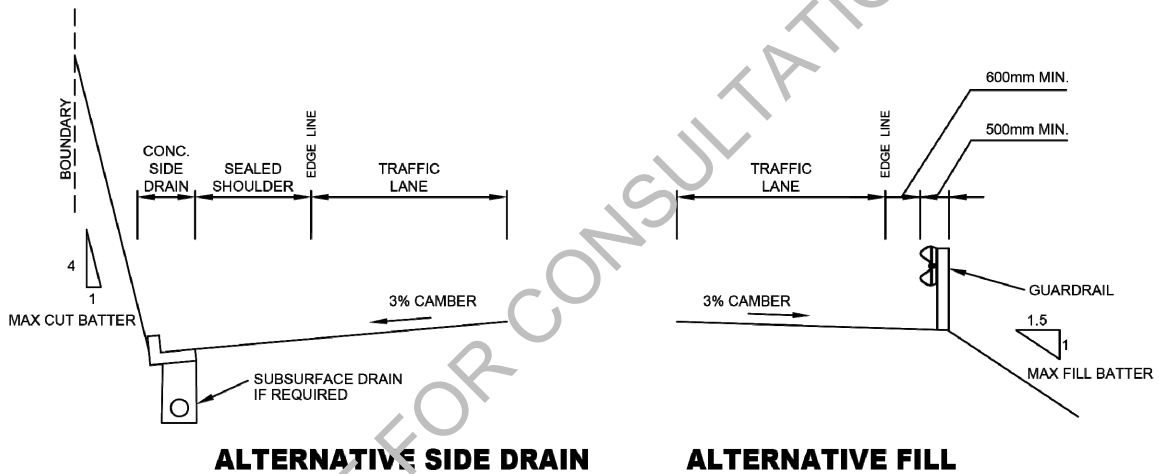

**ALTERNATIVE SIDE DRAIN**

**ALTERNATIVE FILL**

**NOTES –**

1. Individual element dimensions are linked to traffic volume in the rural environment. Refer to Table 3.2 for details.
2. Edge marker post to Motsum guidelines.

**Figure 3.0a - Typical rural road cross section detail**

**3.3.2.2 Sight distance**

Local roads shall be designed to meet sight distance requirements as per the relevant Austroads guide. All roads shall be designed with sight distances that match the target operating speed. Reducing a driver's field of vision in conjunction with other design and management measures is a recognised method for achieving an appropriate speed environment (see 3.3.5).

On connector/collector and arterial roads, sight distance criteria at intersections as well as for stopping, overtaking, on curves, and to avoid obstructions should be applied in accordance with the relevant Austroads or NZTA guides.

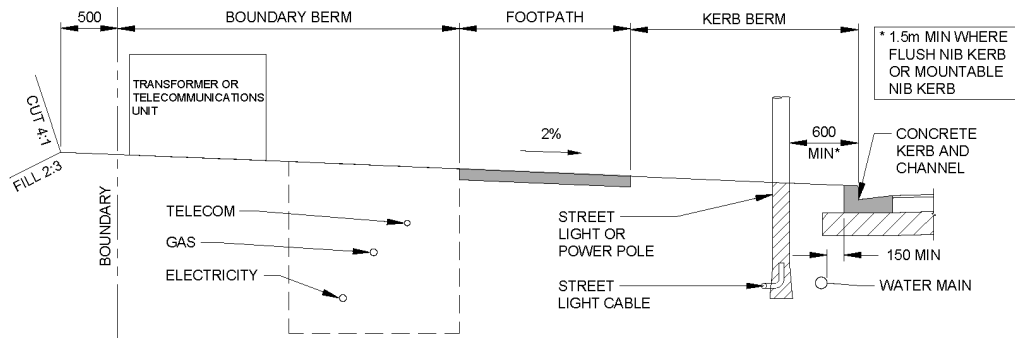

NOTES –

1. Refer to Table 6.4 for clearances, cover to individual services needs to be confirmed with appropriate utility company.
2. Size and position of above ground utility units to meet visibility requirements to carriageway as well as footpath.

Figure 3.0b – Cross section of urban berm indicating road infrastructure, services and utilities

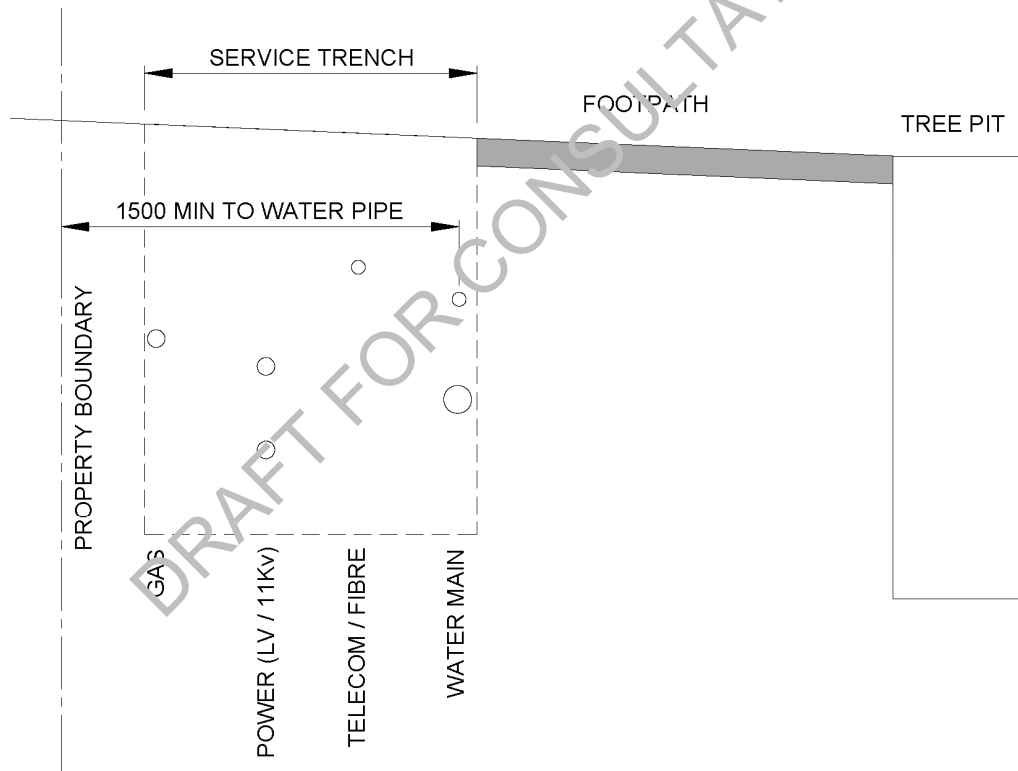

NOTES –

1. Refer to Table 6.4 for clearances between water mains and underground services.
2. Cover to individual services to be as per the NZ UAG recommendations and shall be confirmed with the appropriate utility company.
3. To be approved by the TA.

Figure 3.0c – Common services trench



**3.3.2.3 Widening on horizontal curves**

In some areas the developed road geometry may be constrained, horizontal alignments may involve low radius, or the proportion of commercial vehicles may predominate, such as in *agricultural, industrial, and warehouse* environments. In such instances, movement lanes shall be assessed to determine the need for localised additional width, for example on low radius horizontal curves where the passage of vehicles has the potential to reduce safety. The Austroads *Guide to road design – Part 3: Geometric design* provides useful guidance on this.

**Table 3.1a: Widening on horizontal curves for Primary, Collector and Sub-collector roads (50km/h design speeds)**

Radius (m)	Widening for a two lane pavement width of:		
	6.0 m	7.0 m	8.0 m
30-40	1.75	1.25	0.75
40-50	1.50	1.00	0.50
50-80	1.25	0.75	0.00
80-150	1.00	0.50	0.00
150-200	0.75	0.00	-

**Table 3.1b: Widening on horizontal curves for Local roads (less than 50 km/h design speeds)**

Radius (m)	Widening for a two lane pavement width of:	
	3.5 m	4.5 m
15-20	2.00	1.50
20-25	1.60	1.20
25-30	1.30	1.00
30-40	1.10	0.80
40-50	0.80	0.60
50-60	0.70	0.50
60-80	0.60	0.40
80-100	0.40	0.30
100-200	0.20	0.10
200-200+	0.00	0.00

Table 3.2 - Road design standards

PLACE AND CONTEXT		DESIGN AND ENVIRONMENT				LINK CONTEXT					FIGURE NO.
Area & land use	Local attributes	Locality served	Target operating speed (km/h)	Min. road width (m)	Max grade	Pedestrians	Passing, parking, loading and shoulder	Cyclists	Movement lane (excluding shoulder) (m)	Classification	
RURAL	Access to lifestyle or farming	1 to 6 du	20	6	20%	Shared in movement lane	Allow for passing up to every 50m	Shared	3.0m	Private ROW or private road	R1
		1 to 12 du	30	16	12.5% or as approved by the T.A.	Shared in movement lane	1.0m shoulder (unsealed)	Shared	5.0 – NPDC 6.0 – SDC & STDC	Local road (<120 vpd)	R2
		Rural activities	60	19		Sealed shoulder with edge line if on cycle route	1.2m shoulder (unsealed)	Sealed shoulder with edge line if on cycle route	6.6	Local road (100 to 750 vpd)	R3
			80	20	Sealed shoulder	1.7m shoulder (sealed)	Sealed shoulder	6.6	Local road (750 to 2500 vpd)	R4	
URBAN	Access to houses/ townhouses	1 to 3 du	10 (allow for fire appliance manoeuvring)	4.0	20%	Shared in movement lane	Allow for passing up to every 50m	Shared	3.0	Private ROW or private road	E9
		1 to 6 du		4.5							
	Side or rear service access	1 to 12 du	10 (allow for fire appliance manoeuvring)	7.0	12.5% or as approved by the T.A.	Shared in movement lane	Allow for passing. Parking is not required and shall be off street	Shared	4.0	Maximum of 100m in length (between streets)	E10
		Access to houses/ townhouses	1 to 12 du	20	14	12.5% or as approved by the T.A.	Shared in movement lane	Separate and recessed parking	Shared	3.6 Single direction	Maximum of 100m in length
15	5.5 – 5.7 Bi-directional				Maximum of 250m in length						

PLACE AND CONTEXT		DESIGN AND ENVIRONMENT				LINK CONTEXT					FIGURE NO.
Area & land use	Local attributes	Locality served	Target operating speed (km/h)	Min. road width (m)	Max grade	Pedestrians	Passing, parking, loading and shoulder	Cyclists	Movement lane (excluding shoulder) (m)	Classification	
URBAN (continued)	Primary access to housing	Servicing up to 200 du	40	17	12.5%	1.5m footpath required both sides	Separate and recessed parking	Shared	5.5 – 5.7	Local road (~2000 vpd)	E12
				19			Parking shared in movement lane		7.2 – 7.5		
	Primary access to housing	Servicing up to 800 du	50	20	10%	1.8m footpath required both sides	Separate and recessed parking	Shared 2.0m each side	2 x 4.2	Connector/ connector road (~8000 vpd)	E13
				22					6.6 – 7.0		
	Primary freight access	Industrial area	30	16 – 18	10%	1.5m footpath one side	Parking shared in movement lane (not marked)	Shared	2 x 4.2m MIN	(~2000 vpd)	NPDC ONLY H1

Figure R2

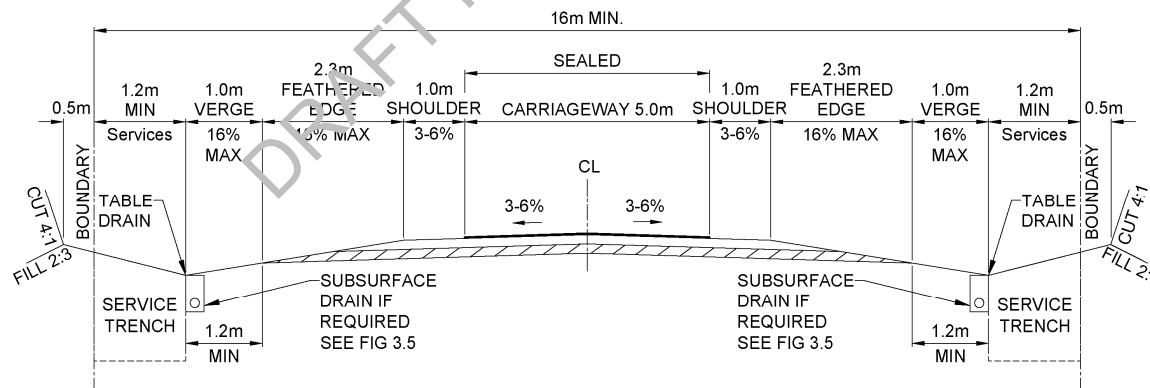
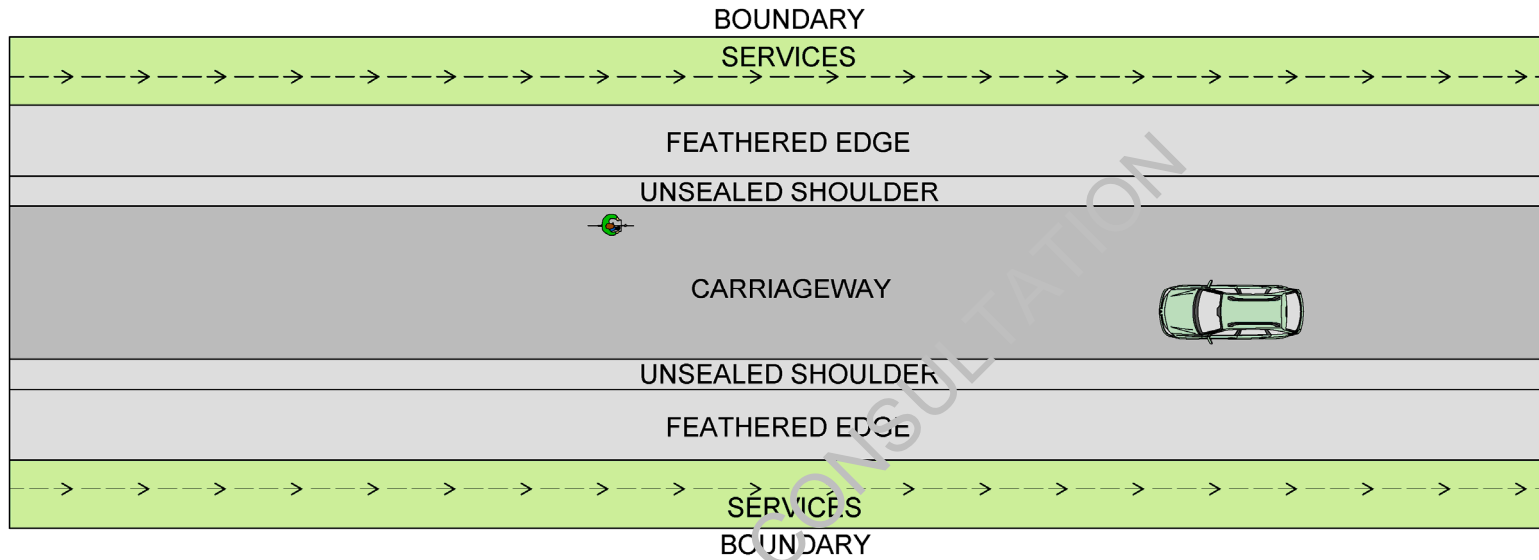

Figure R3

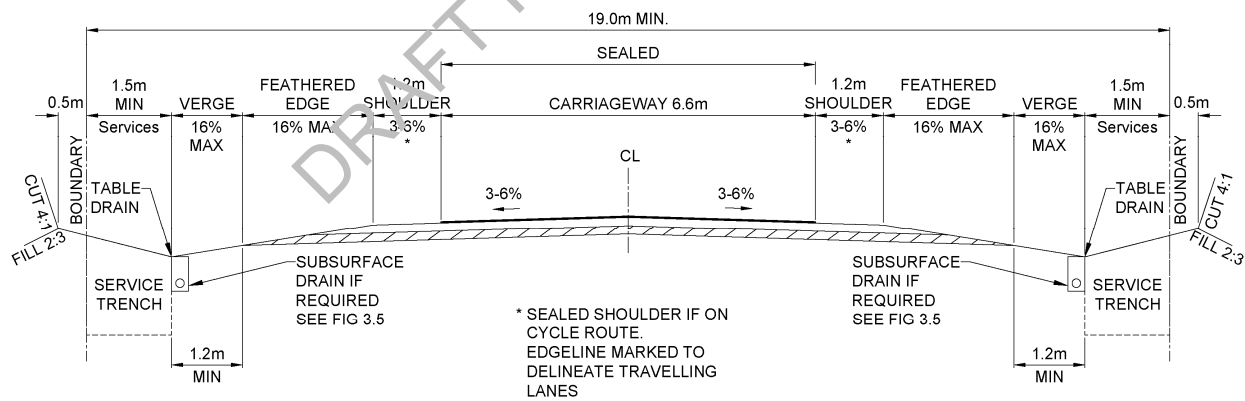
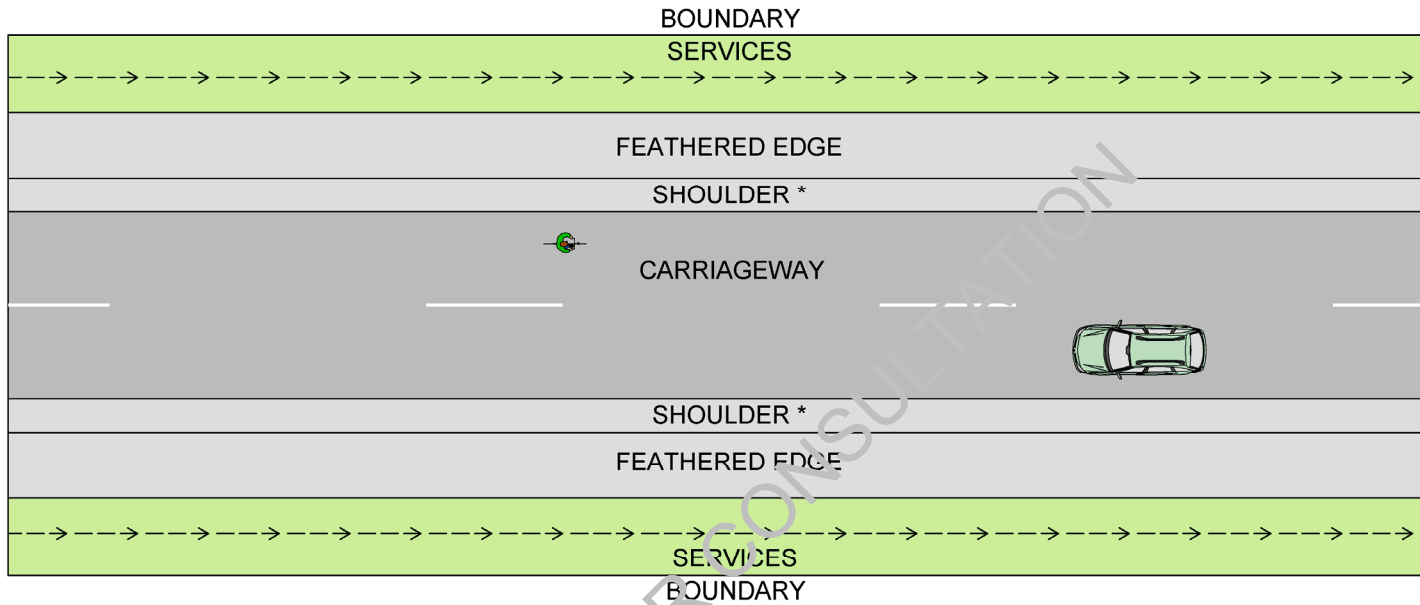

Figure R4

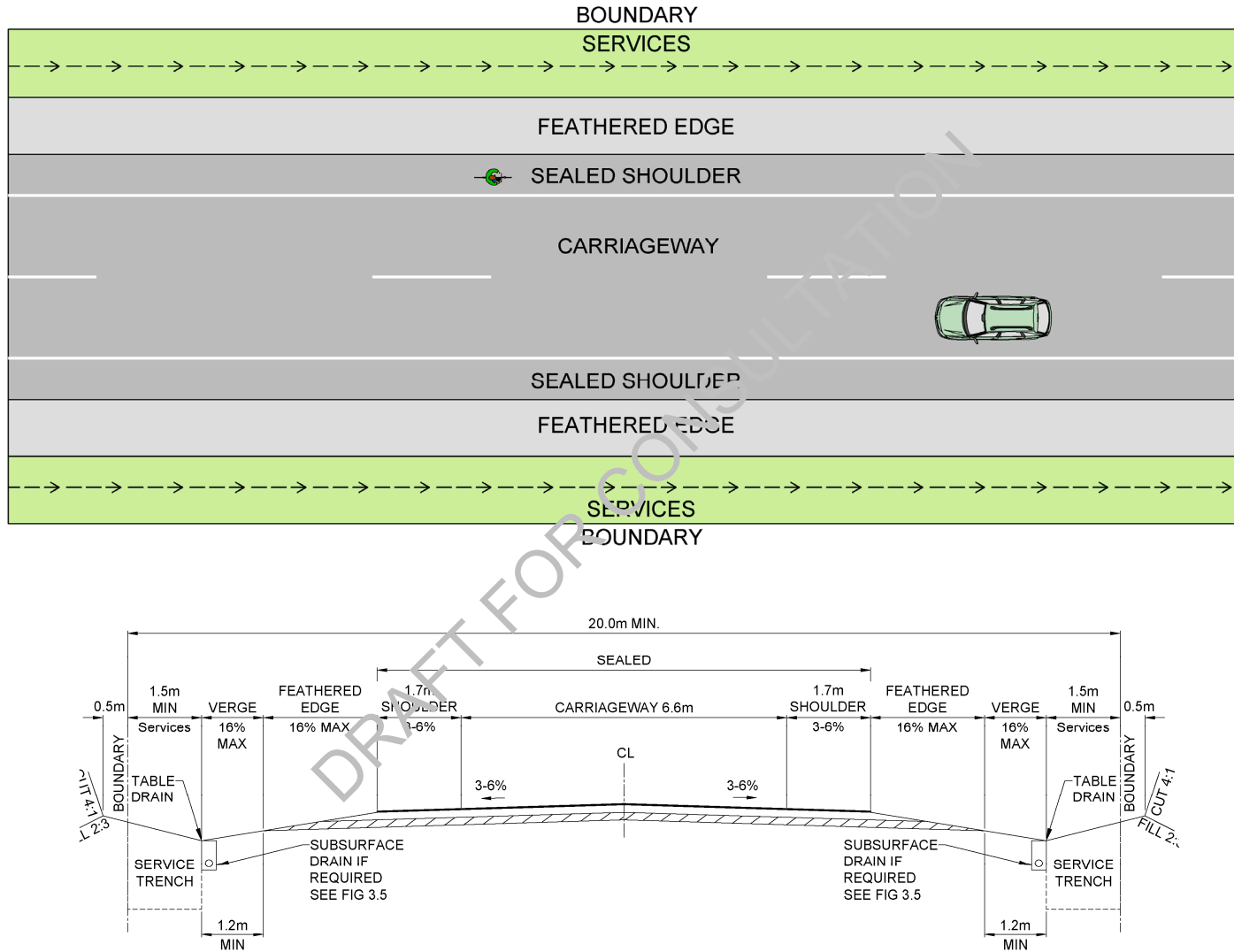

Figure E11 – One Direction

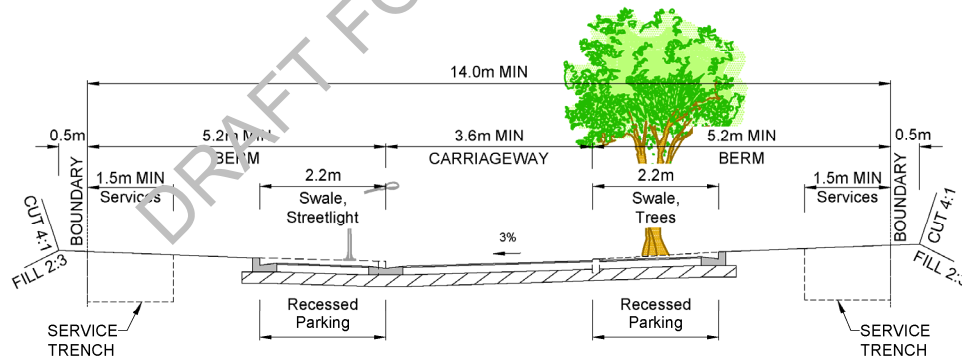
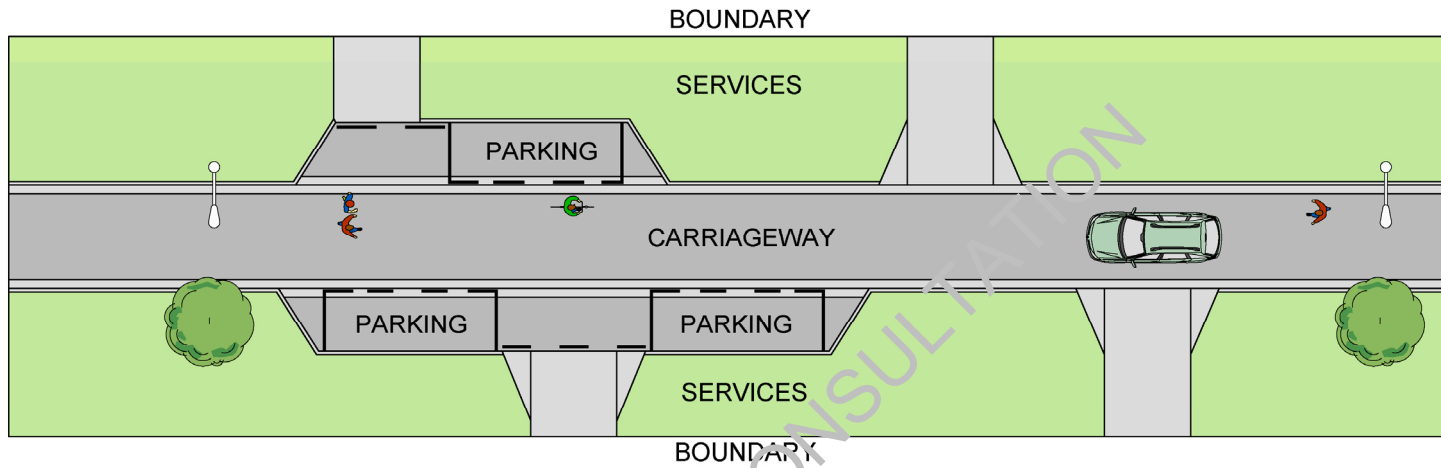

Figure E11 – Bi-directional

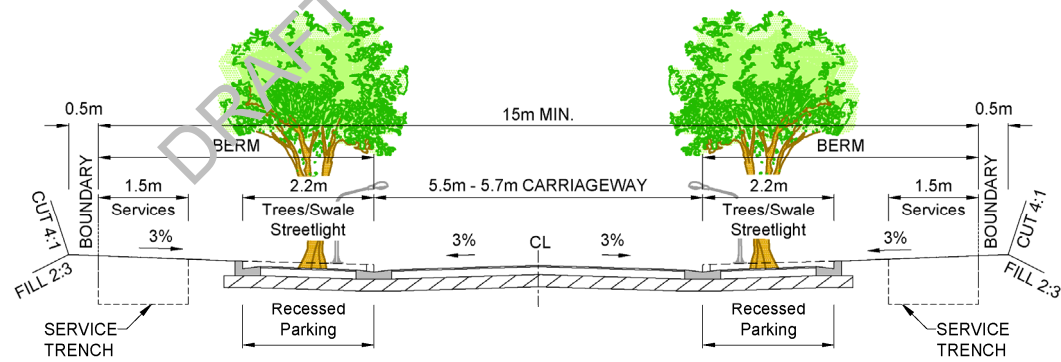
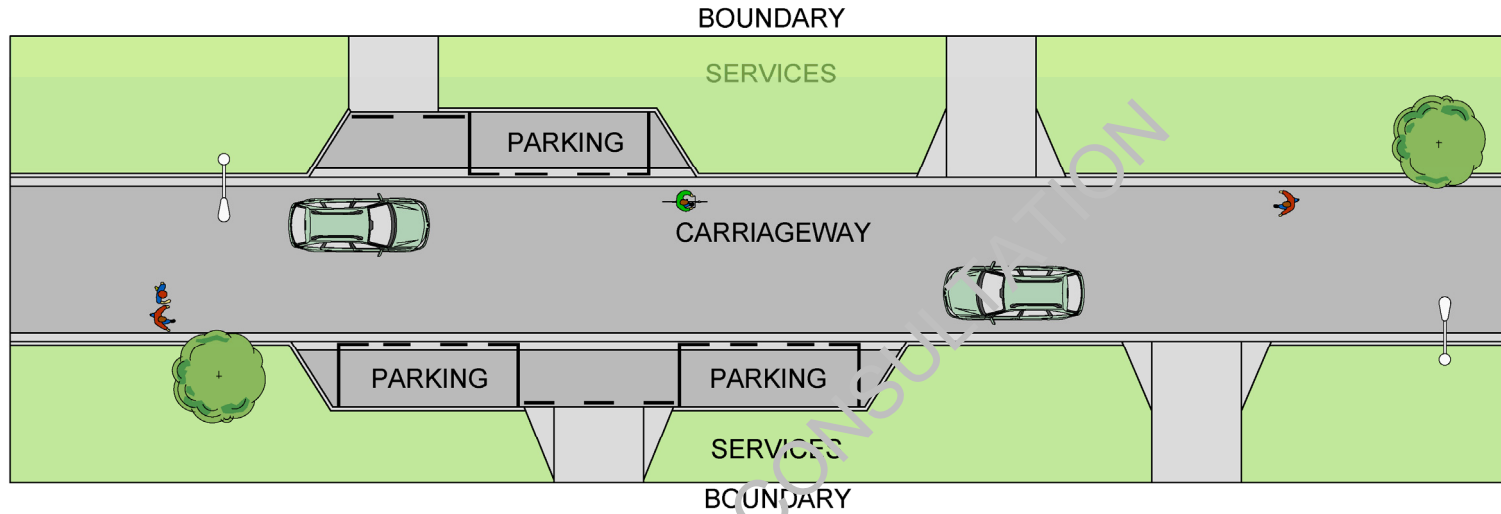



Figure E12

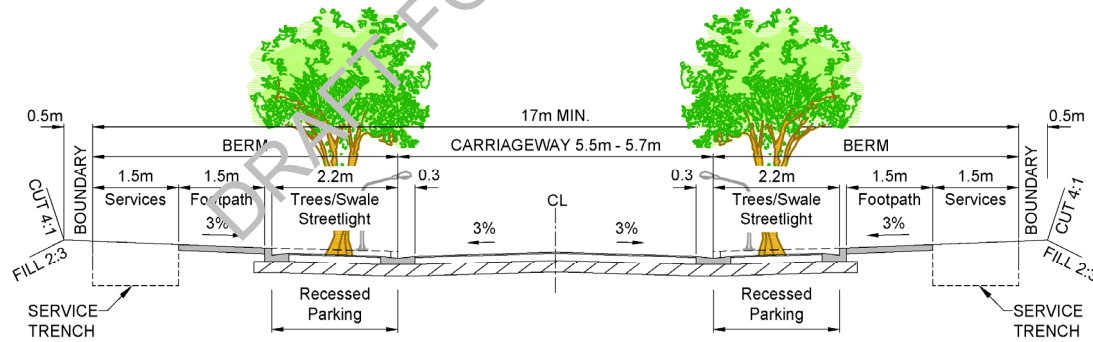
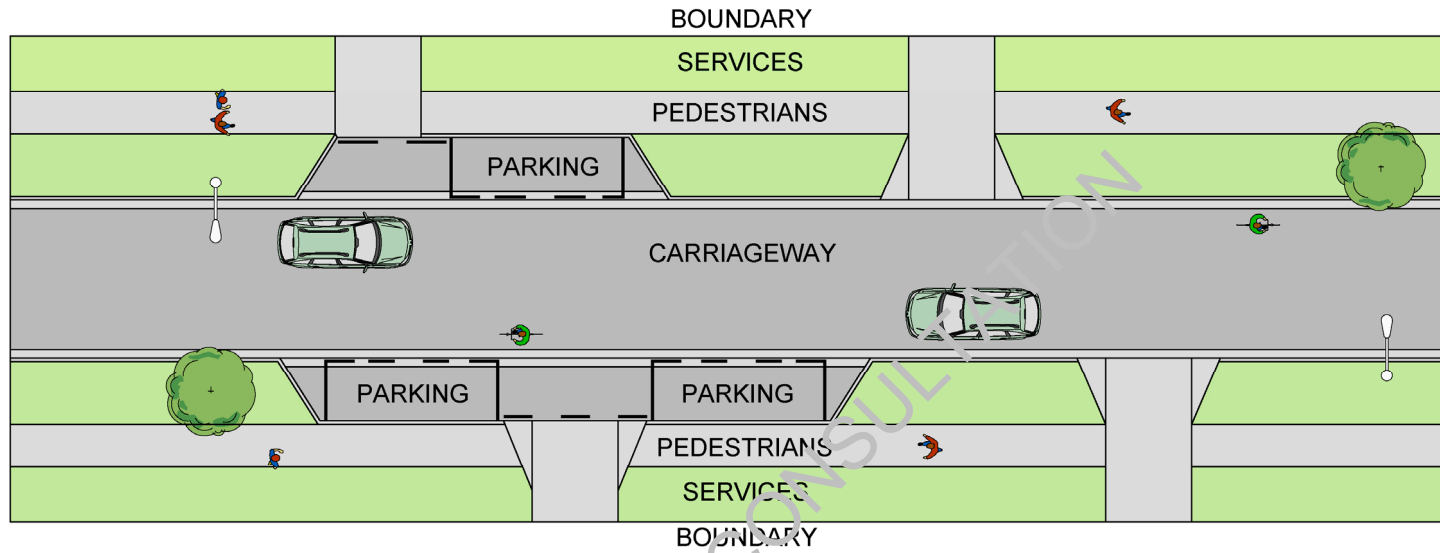

Figure E12

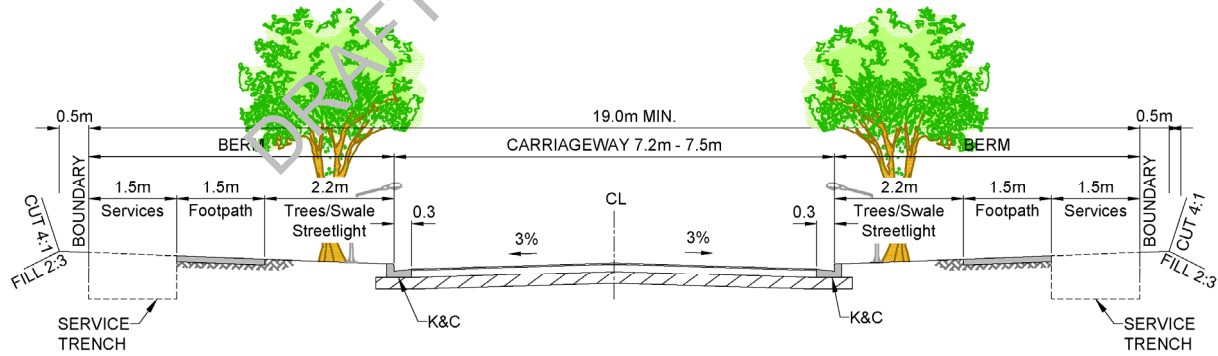
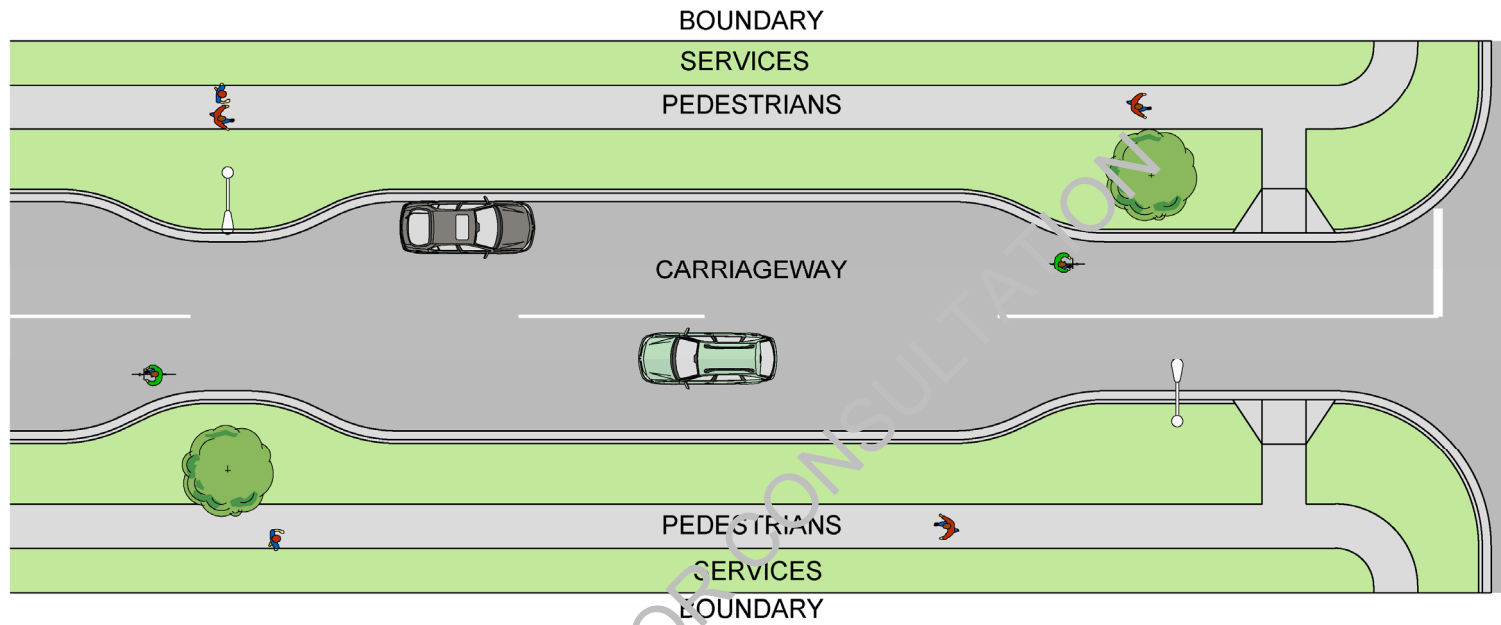

Figure E13

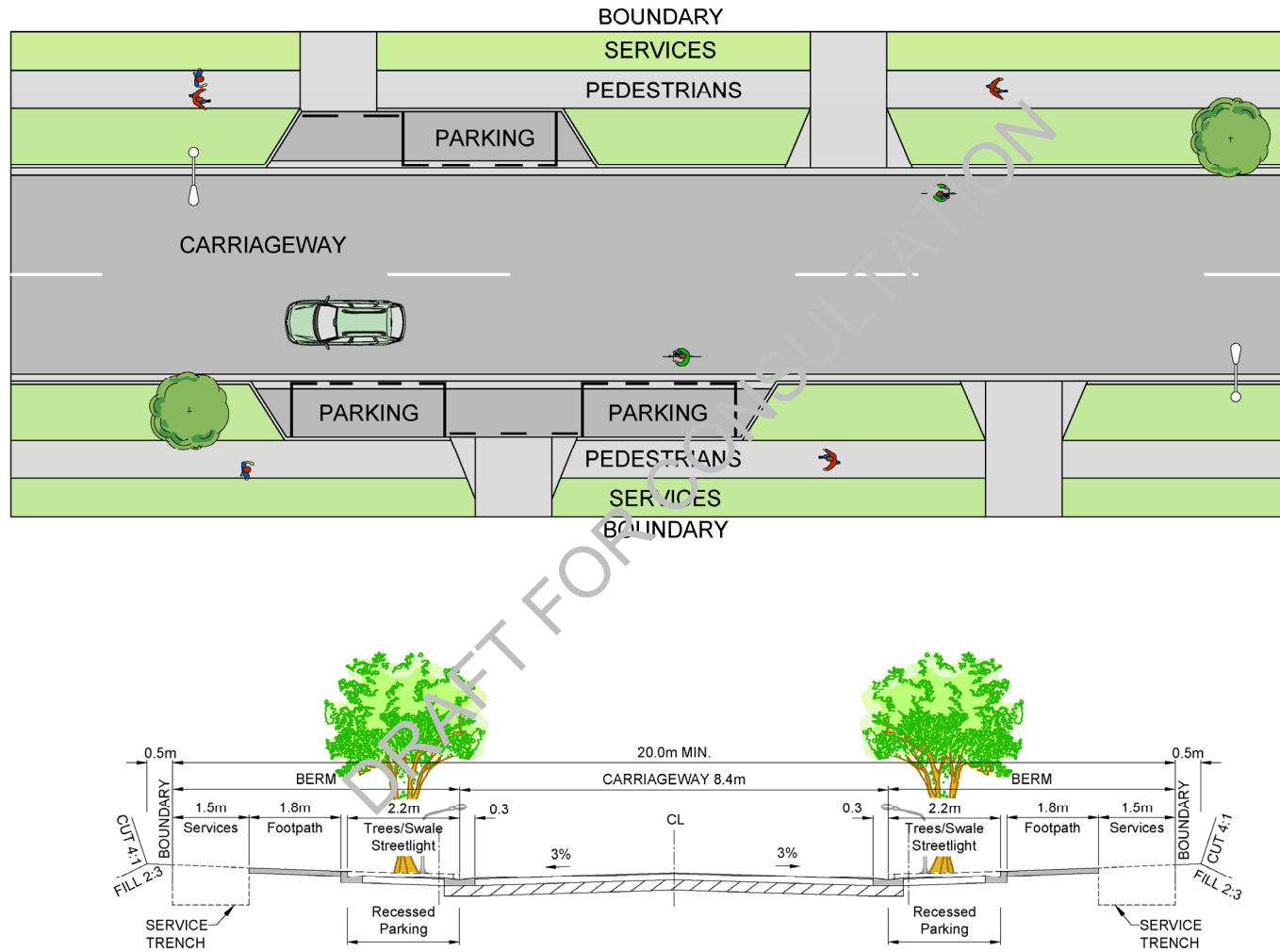

Figure E13

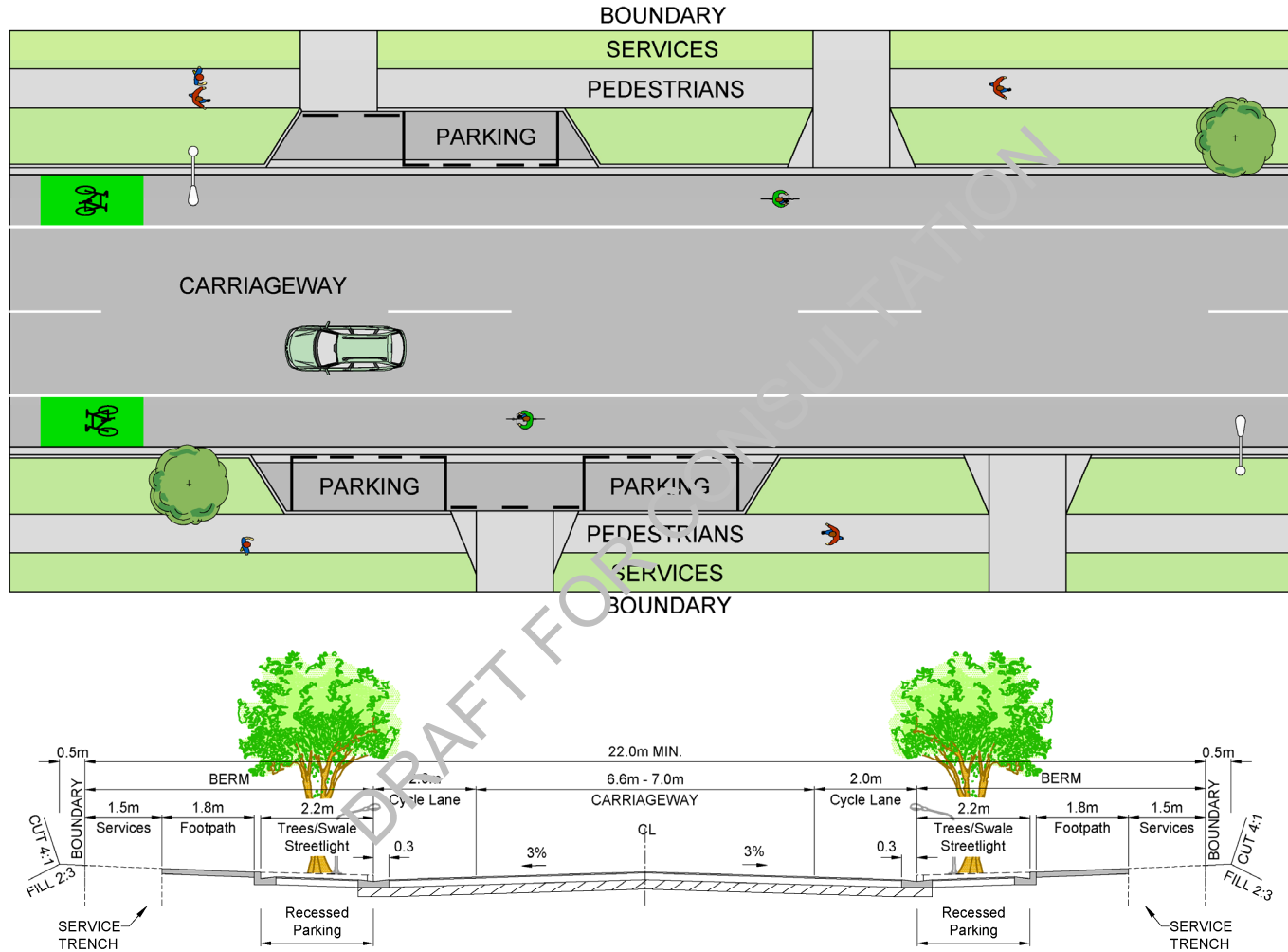

Figure H1

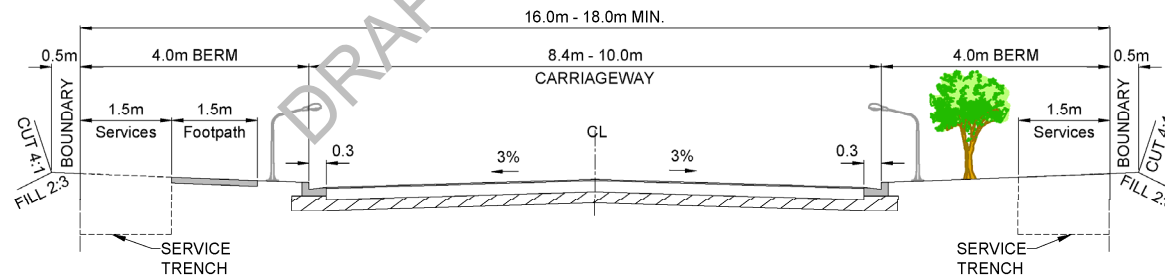
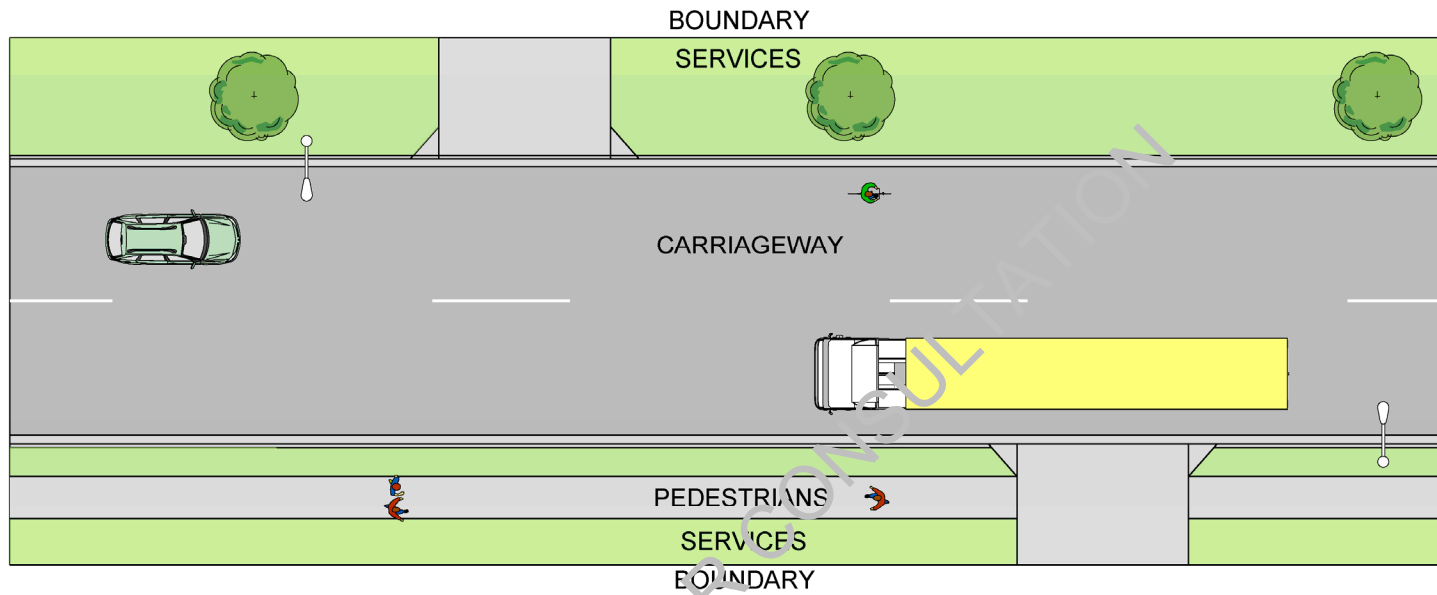
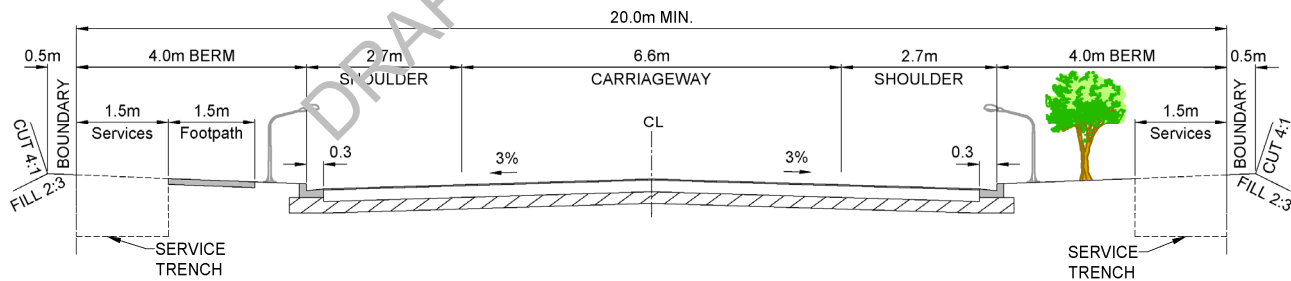
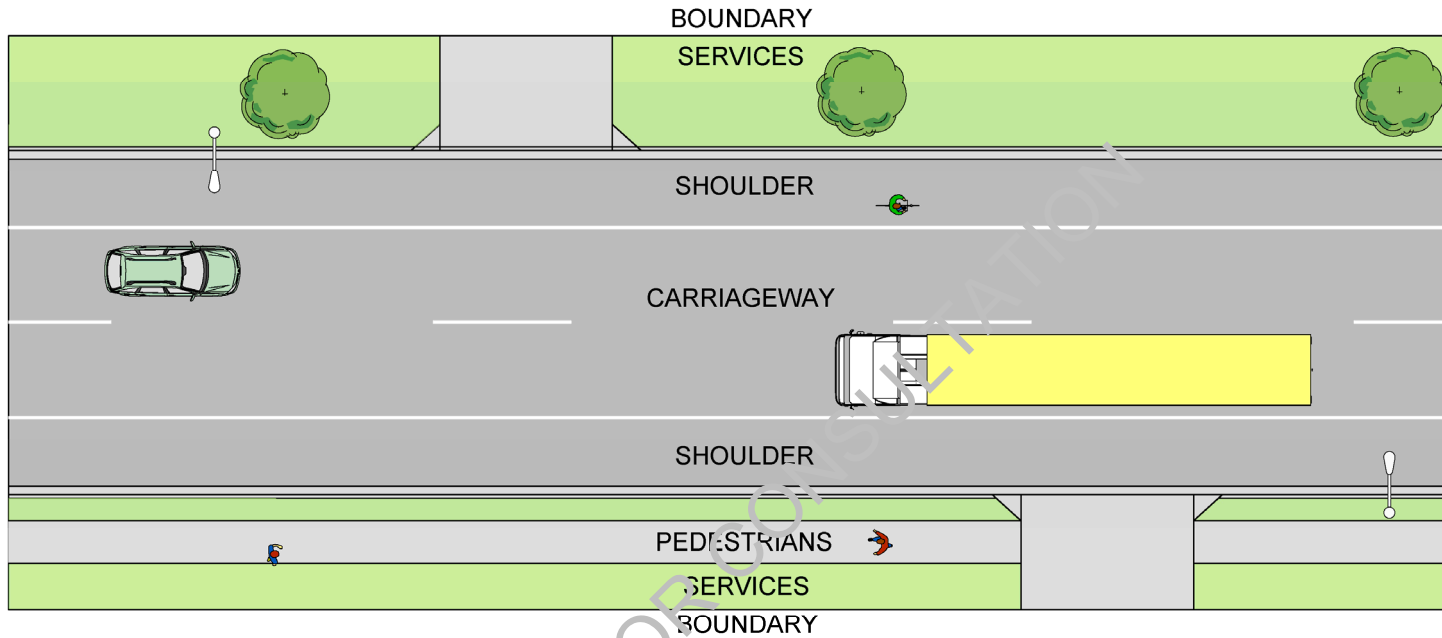

Figure H2



### 3.3.3 Pavement structural design

Generally pavements shall be flexible designs. Other types of pavements shall be subject to TA approval. Pavements shall be designed in accordance with the Austroads guides with a design life of 25 years.

#### C3.3.3

*For roads of connector/collector class or above, structural design should be undertaken by mechanistic design methods. For other roads, mechanistic or other industry standard chart based methods may be used. Table 3.2a below may be used for R1 and E9 right of ways/private roads.*

**Table 3.2a – Pavement design parameters**

Vehicles per day		Subbase Depth	Basecourse Depth	Pavement Depth
Urban	Rural	(mm)	(mm)	(mm)
0-550	0-200	150	100	250
>550	>200	Subject to SPECIFIC DESIGN		

This is based on the following assumptions:

- Subgrade CBR  $\geq 7$  (Refer 3.3.3.2 CBR tests)
- Traffic growth rates  $\leq 1\%$
- Percentage HCV: Urban  $\leq 2\%$  or Rural  $\leq 6\%$

#### 3.3.3.1 California bearing ratio design method for rigid and flexible pavements

Soaked California bearing ratio (CBR) values of the pavement subgrade shall be used and the pavement designed for the estimated number of equivalent standard axle (ESA) loadings over a 25-year design life.

#### 3.3.3.2 California bearing ratio tests

CBR values shall generally be determined in the laboratory according to 6.1 of NZS 4402.6.

For local roads an alternative method of determining subgrade CBR in non-granular materials by Scala Penetrometer may be acceptable for clay and colluvial materials.

Figure 3.1 shows a correlation between Scala penetration and CBR values. This should be used conservatively.

The CBR value used in the design shall be the 10th percentile value of the CBR tests taken on the subgrade material. A selection of tests shall be taken at 150, 300, and 450 mm below final subgrade level.

Where CBR values are required for aggregates, these shall be based on laboratory tests prepared on the fraction passing the 19 mm sieve but a CBR of more than 30 shall never be used. The use of CBR on metal layers shall only be in conjunction with consideration of the CBR and stiffness of lower layers.

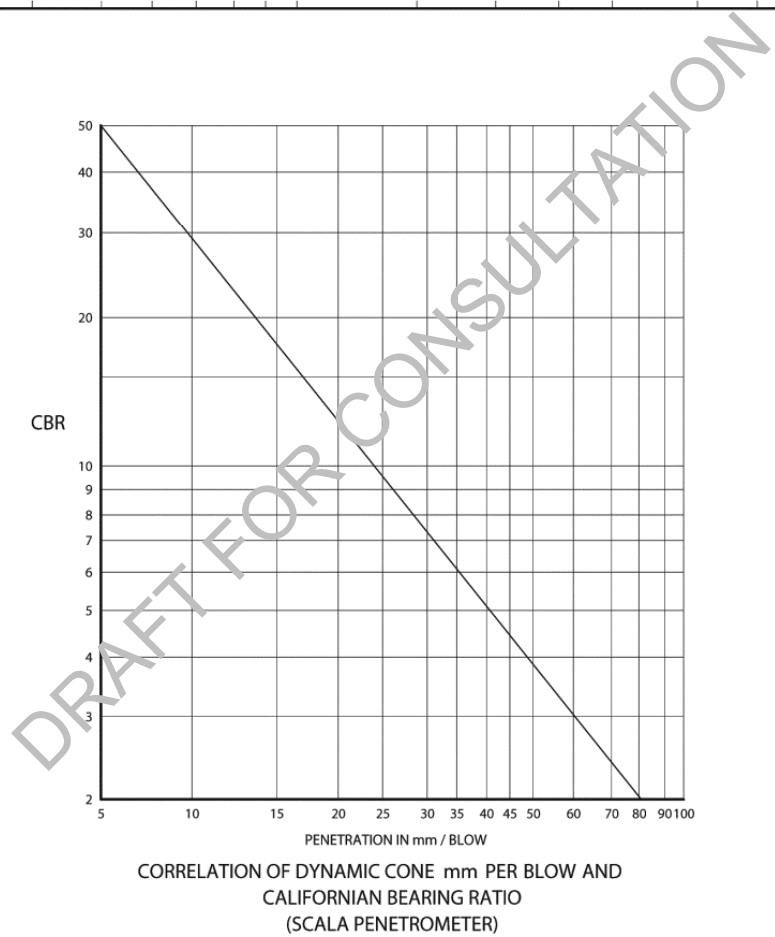
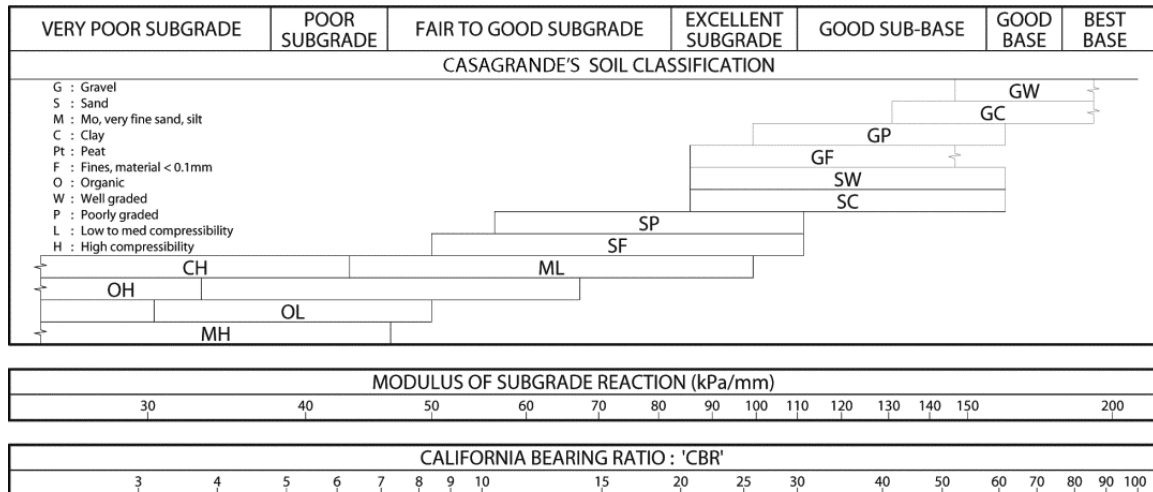

**Figure 3.1 - Parameter relationship**



### 3.3.4 Safety barrier provisions

#### 3.3.4.1 Pedestrian and cycle barriers

Where safety barriers for pedestrian and cyclists are necessary, they shall comply with *Figure 3.2a Safety Fence and Cycle Chicane* and NZS/AS 1657.

#### 3.3.4.2 Urban vehicle barriers

Where safety barriers for vehicles in urban areas are necessary, they shall comply with the design requirements of NZTA RTS 11: *Urban roadside barriers and alternative treatments*.

#### 3.3.4.3 Rural vehicle barriers

Where safety barriers for vehicles in rural areas are necessary, they shall comply with the design requirements in AS/NZS 3845.

### 3.3.5 Target operating speed

Traffic management shall be included in road design to ensure that the target operating speed shown in Table 3.2 is achieved. Target operating speed can be managed by physical and psychological devices such as narrowed movement lanes, reduced forward visibility, parking, slow points, build outs, leg lengths, chicanes, planting and landscaping, and street furniture and art works.

The Austroads *Guide to traffic management – Part 8: Local area traffic management* provides suitable guidance for designing to a target operating speed. Reference can also be made to the *Manual for streets* (UK Department for Transport 2007). Figure 3.2 provides information on estimating traffic speeds for particular circumstances.

#### C3.3.5

The two key geometric factors that contribute to achieving the target operating speed are carriageway width and forward visibility. Figure 3.2 can be used to give an indication of the speed at which traffic will travel for a given carriageway width/forward visibility combination. (Reference: UK Department for Transport, 'Manual for streets'. Figure 3.2 is adapted from figure 7.16 in the reference and 'TRL661 – The manual for streets: evidence and research'). It is recommended that the user interpolate the design street width between the guide lines shown to determine relative street width and forward visibility.

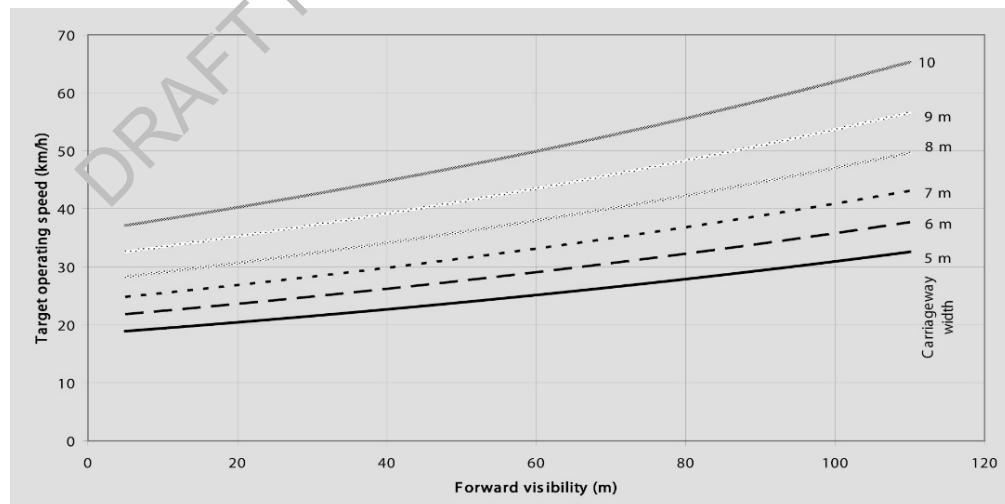

Figure 3.2 - Influence of road geometry on speed

### 3.3.6 Parking, passing, and loading

Parking and loading can be provided either on or off-street. Facilities shall meet the needs of the area and the requirements of the TA, and shall be addressed in the design and access statement (see 3.2.6). Further guidance can be found on the Trips Database Bureau website <http://www.tdbonline.org/home>.

Passing provision shall be in accordance with the design guidance in Table 3.2 and 3.2a and the requirements of the TA.

Acceptable and alternative on-street car park and loading dimensions should be taken from AS 2890.5, *AS/NZS 2890.1* and/or the Austroads guides.

Parking and loading shall not be provided so that it has the potential to obstruct the movement of emergency or service vehicles along a road. Alternate provision within sites may be demonstrated in addition to the requirements of the district plan, particularly when establishing rules for new subdivisions.

### 3.3.7 Intersection and alignment design

The angle of intersection should be 90°, although a minimum angle of 70° can be used when justified by other constraints. Carriageway alignment may be offset within the street reserve to achieve the required target operating speed for the road.

All road intersections in *residential and recreational* areas below arterial class should have a kerb radius at intersections of 4 m to 6 m. An alternative and reduced kerb radius may be considered to enhance pedestrian facility in low speed environments, and shall be subject to the approval of the TA.

All intersections in *agricultural, industrial, and warehouse* areas should have a minimum kerb radius of 13.5 m with corner splays of 6 m, or subject to specific design. *Heavy duty kerb and channel shall be used for all radius kerbs at intersections and elsewhere as required by the Standard or as directed by the TA.*

Intersections in all other 50 km/h or lower speed environments shall have the lot corners splayed by a minimum of 4 m along both boundaries, although these may be dispensed with in low target operating speed situations provided that there is adequate provision for pedestrians and utility services. Corner boundary splays shall be subject to specific design in higher speed environments, to ensure safe visibility at intersections.

Reference can also be made to Austroads guides.

*Intersection separation distances shall meet the following requirements, centre line to centre line*

- *On arterial roads: 150m*
- *On collector/connector/distributor roads: 150m*
- *On local roads: 40m*
- *On rural roads in 100 km/hr speed environment: 300m*
- *On rural roads in speed environments less than 100 km/hr: to be determined on basis of operation speed, traffic volumes and road hierarchy.*

### 3.3.8 No-exit roads

'No-exit' roads should not be provided where through roads and connected networks can be designed. Where no-exit roads are provided, they should ensure connectivity for pedestrians and cyclists.

No-exit roads and lanes shall provide for road turning at the end of the road for an appropriate vehicle as described in RTS 18: *New Zealand on-road tracking curves for heavy vehicles*. The design of turning facilities for light vehicles shall be in accordance with AS 2890.5. See Figures 3.3 and 3.3a for acceptable solutions.

An on-road turning area may provide for parking or landscaping in the centre of the turning area. The minimum kerb gradient around turning heads shall be 0.5%. Appropriate drainage shall be provided.

*Turning heads shall preferably be graded with the low point and sumps positioned in proximity of the tangent points of the turning head.*

*Heavy duty kerb and channel to be used around the full length of the turning head between the tangent points.*

*Standard/mountable profile to be approved by the TA.*

*If to be used by the rubbish removal truck, consideration should be given to one or two commercial crossings on the turning head in residential areas.*

### **3.3.9 Bus stops**

Bus stops shall be provided for on connector/collector roads or arterials in accordance with the TA direction in consultation with the regional transport authority. Bus stops may be designed in accordance with ARTA *Bus stop infrastructure design guidelines*.

### **3.3.10 Special road and footpath provisions near places of assembly**

Designs for areas adjacent to places of public assembly including schools, hospitals, shopping areas, and public halls, shall incorporate special provisions such as extra parking spaces, stopping lay-bys, widened footpaths, bus and taxi stops, *mobility* crossings, loading zones, and any associated facilities to ensure the safety of concentrations of vehicles and pedestrians.

### **3.3.11 Footpaths, accessways, cycle paths, and berms**

Pedestrians, cyclists, and berms shall be provided for in accordance with Table 3.2. Dimensions, strength, durability, and finish shall be appropriate to their use and expected loadings. Paths shall be designed in accordance with Austroads guides and NZTA *Pedestrian planning and design guide*.

Where accessways separate from the roads are to be illuminated, they shall be to the standard of illumination recommended in AS/NZS 1158.3.1.

#### **3.3.11.1 Footpaths and accessways**

Footpaths shall be a minimum of 1.5 m wide surfaced over their full width. The crossfall should be no greater than 2%. Wider footpaths or areas of local widening will often be required by the TA where higher use or other needs dictate such widening.

Accessways should be provided at no-exit roads or where necessary to improve connectivity. They shall be designed for user safety using crime prevention through environmental design (CPTED) principles and should:

- (a) Be direct and no greater than two properties long;
- (b) Have good sight lines for passive surveillance with fences a maximum height of 1.2 m for 10 m from the road frontage, or no fencing;
- (c) Be sited to ensure high levels of community use;
- (d) Be amenity landscaped without compromising safety;
- (e) Have provision for the disposal of stormwater;
- (f) Be provided with pedestrian level lighting;
- (g) Have a legal width not less than 5.5 m.

*Where permanent fences are required to guide pedestrians then safety fences as detailed in Fig. 3.2a shall be erected.*

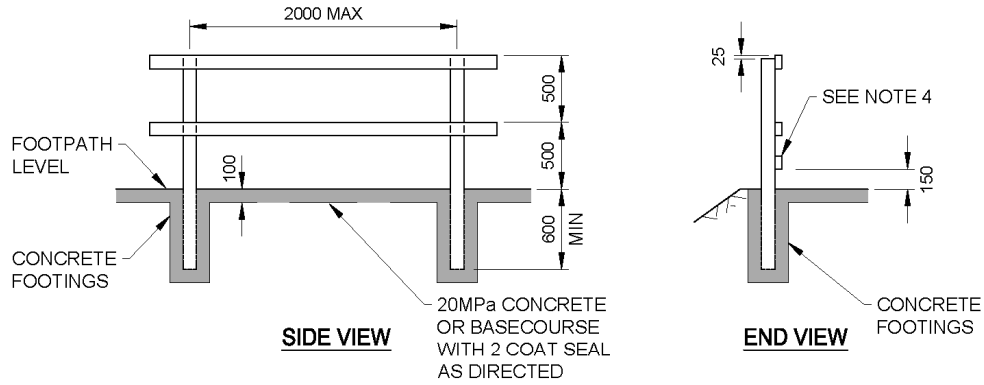

**SAFETY FENCE**

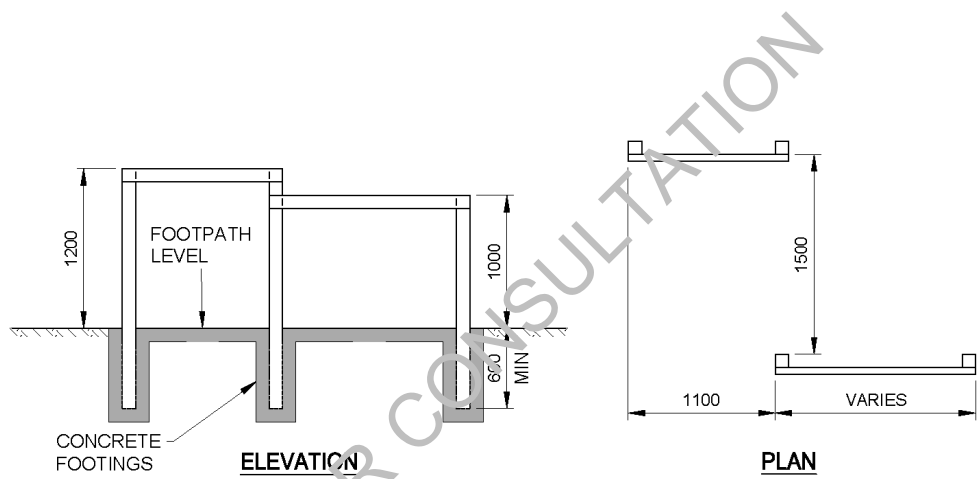

**CYCLE CHICANE**

TO BE ERECTED ON EACH SIDE OF PEDESTRIAN ACCESSWAYS AND ELSEWHERE AS DIRECTED

**NOTES –**

1. All timber shall be treated toxic.
2. Posts shall be 100x100 with chamfered top and shall be tamped firmly into ground.
3. Rails shall be 100x50 fixed with 100mm galvanised nails. Joints shall be half scarfed.
4. An additional rail, 150mm above path level, shall be used where the ground drops steeply away from the fence.
5. Posts shall be increased to 150x100 where the fence is adjacent to a carriageway.
6. Exposed timber shall be primed and given one coat of white paint.
7. The cycle stop shall be extended as necessary to prevent by-passing.

**Figure 3.2a - Safety fence**

**3.3.11.2 Cycle paths**

Separate cycle paths shall be provided where good design requires separation from the carriageway or a different route to be selected.

Stormwater disposal shall be provided to all off-road cycle paths. Lighting is to be provided where appropriate.

Cycle facilities shall be designed to the standards as set out in the Austroads guides and the NZTA *Cycle network and route planning guide*.

**3.3.11.3 Footpath and cycle path surfacing**

All footpaths and cycle paths shall be surfaced with a permanent surfacing layer appropriate to the surrounding environment and level of use expected.

Acceptable surfacing for footpaths and cycle paths are:

- (a) *Plain surfaced uncoloured concrete;*
- (b) *All other surfaces to be approved by the Council.*

Other acceptable surfacing for footpaths are:

- (c) Concrete pavers;
- (d) Other pavers may be approved by a TA in areas of high aesthetic value;
- (e) Chipseal (grade 6) may be approved by a TA in areas of very low pedestrian traffic;
- (f) Metal surfaces may be appropriate in rural areas;
- (g) Permeable or porous paving may be approved by a TA.

In all cases the surfacing shall be placed over compacted basecourse which in turn shall be placed over a firm subgrade with all organic soft material removed.

**3.3.11.4 Berms**

Grassed or planted berms between the road legal boundary and carriageway shall be provided in accordance with the landscape character intent for each street type within the development. For streets with high pedestrian activity, a full footpath (with no berms) may be more appropriate. Residential streets with a lower pedestrian activity may have a ribbon footpath (planted berms between footpath and carriageway, and between footpath and road boundary).

In all cases the combined berm and footpath width shall be as required by the TA to be adequate to enable landscaping and all current and expected services to be installed.

Where a berm crossfall greater than 1 in 12.5 is proposed, the designer shall produce a cross section along suitable individual property access locations to show that the sag or summit curves at crossings can be satisfactorily negotiated by a 90th percentile car.

*The berm shall incorporate not less than 100mm compacted thickness of loam topsoil or brown ash.*

*Topsoil shall be prepared in accordance with section 7.4.2.*

Berms shall be of adequate width to:

- (a) Achieve safe clearances between the carriageway edge and any obstacle;
- (b) Allow running of utility services and placing of lighting poles within the berm unless approved otherwise by the utility provider or the TA;
- (c) Provide adequate space between the road reserve boundary and the carriageway edge to enable residents to safely enter the road traffic;
- (d) Allow room for efficient road edge and edge drain maintenance; and
- (e) Allow adequate space for the effective operation and maintenance of any form of stormwater management device. *Refer to 3.3.19.5 for swale information and requirements.*

**3.3.12 Traffic signs, marking, and road furniture**

The design shall incorporate all required road marking, signs, and other facilities appropriate to the place and link context. Roads should be designed to minimise the need for traffic signs and marking.

*Single sided trail markers are to be located at each end of pedestrian and cyclist accessways and shall be provided by the TA's preferred supplier to ensure the correct information is clearly displayed. The final design shall be subject to TA approval.*

Designs shall satisfy the Land Transport Rule (Traffic Control Devices) 2004 and linked traffic sign specification, and the NZTA *Pedestrian planning and design guide*. All road markings and traffic signs shall be approved by the TA.

All fire hydrants shall be marked in accordance with NZS/BS 750.

Road name signs shall comply with the TA's current road names standards and their mounting shall be provided by the developer to the TA's requirements.

Seats, signs, and other street furniture shall be designed and placed in accordance with the TA's requirements. Furniture used should unless expressly approved otherwise be compatible with a TA's existing street furniture.

*The requirement for street name blades are:*

<b>Parameter</b>	<b>Rural</b>	<b>Urban</b>	<b>Private</b>
<i>Blade Depth</i>	<i>250mm</i>	<i>200mm</i>	<i>200mm</i>
<i>Background colour</i>	<i>Blue (NPDC and STDC), Green (SDC)</i>	<i>Blue (NPDC and STDC), Green (SDC)</i>	<i>White</i>
<i>Letter colour</i>	<i>White</i>	<i>White</i>	<i>Black</i>
<i>Letter height</i>	<i>150mm</i>	<i>100mm</i>	<i>100mm</i>
<i>Letter type series</i>	<i>D (upper case)</i>	<i>D (upper case)</i>	<i>D (upper case)</i>
<i>Branding</i>	<i>NPDC logo or SH Shield</i>	<i>NPDC logo or SH Shield</i>	<i>None</i>

### 3.3.13 Trees and landscaping

See section 7 of this Standard.

### 3.3.14 Road lighting

All road lighting shall be designed and installed in compliance with the recommendations of AS/NZS 1158, NZTA *M30 Specification and Guidelines for Road Lighting Design*, Austroads guides or guidelines adopted by the TA at that time.

*Exempting commercial zone upgrades, one of the following may be used for new additions to the network. Alternative systems may be used subject to the Council's approval.*

*Columns*

- (a) *CSP Pacific Steel Octagonal (Oclyte) – 7.6m with 2.0m outreach.*
- (b) *CSP Pacific Steel Octagonal (Oclyte) – 10.3m with 2.0m outreach.*
- (c) *Any other octagonal shaped column that is interchangeable with a CSP octagonal shaped column and approved by the Council.*
- (d) *Or as approved by the TA.*

*Outreach Arm*

- (a) *CSP Pacific Steel Octagonal (Oclyte) 2.0m outreach.*
- (b) *Or as approved by the TA.*

*Lamps*

*Street light design can be found in the Resources section of the NZTA website under Specification and Guidelines for Road Lighting Design, Accepted Luminaires.*

*A street lighting design can be undertaken to incorporate the location and predicted height of street trees. Careful consideration needs to be given to the balance between street lights and street trees to ensure effective lighting occurs e.g. trees to be a minimum of 8m clear of streetlights or as approved by the TA.*

**3.3.15 Bridges and culverts**

Bridges and culverts may require separate resource and building consents. All bridges and culverts shall be designed in accordance with the NZTA Bridge manual.

Particular features to be considered/covered include:

- (a) **Widths/lengths:**  
All bridges and culverts shall be designed with a width to accommodate movement lane, cycle, and pedestrian needs of the road (see Table 3.2);
- (b) **Roadside barriers:**  
See 3.3.4;
- (c) **Batter slope protection:**  
All culverts shall have anti-scour structures to protect batter slopes, berms, and carriageways;
- (d) **Clearance over traffic lanes:**  
Where passing above traffic lanes, bridges shall have the full clearance of 5.2 m to provide clearance for over dimension vehicles able to operate without a permit;
- (e) **Foundations:**  
All bridges and culverts shall be founded to resist settlement or scour. Abutments shall be designed to ensure bank stability and provide erosion or scour protection as applicable;
- (f) **For waterway design see section 4,**
- (g) **Culvert outlets**  
*All culvert outlets and formation on embankments have to be protected from undercutting through scour and erosion. A flume is detailed in Figs 3.2b and 3.2c.*  
  
*Where erosion is likely to occur in the stream bed due to high velocities from the culvert outlets stone protection as detailed in Figs 3.2d and 3.2e shall be constructed.*
- (h) **Stock underpasses**  
*Stock underpasses shall be constructed to the requirements of bridges and culverts.*

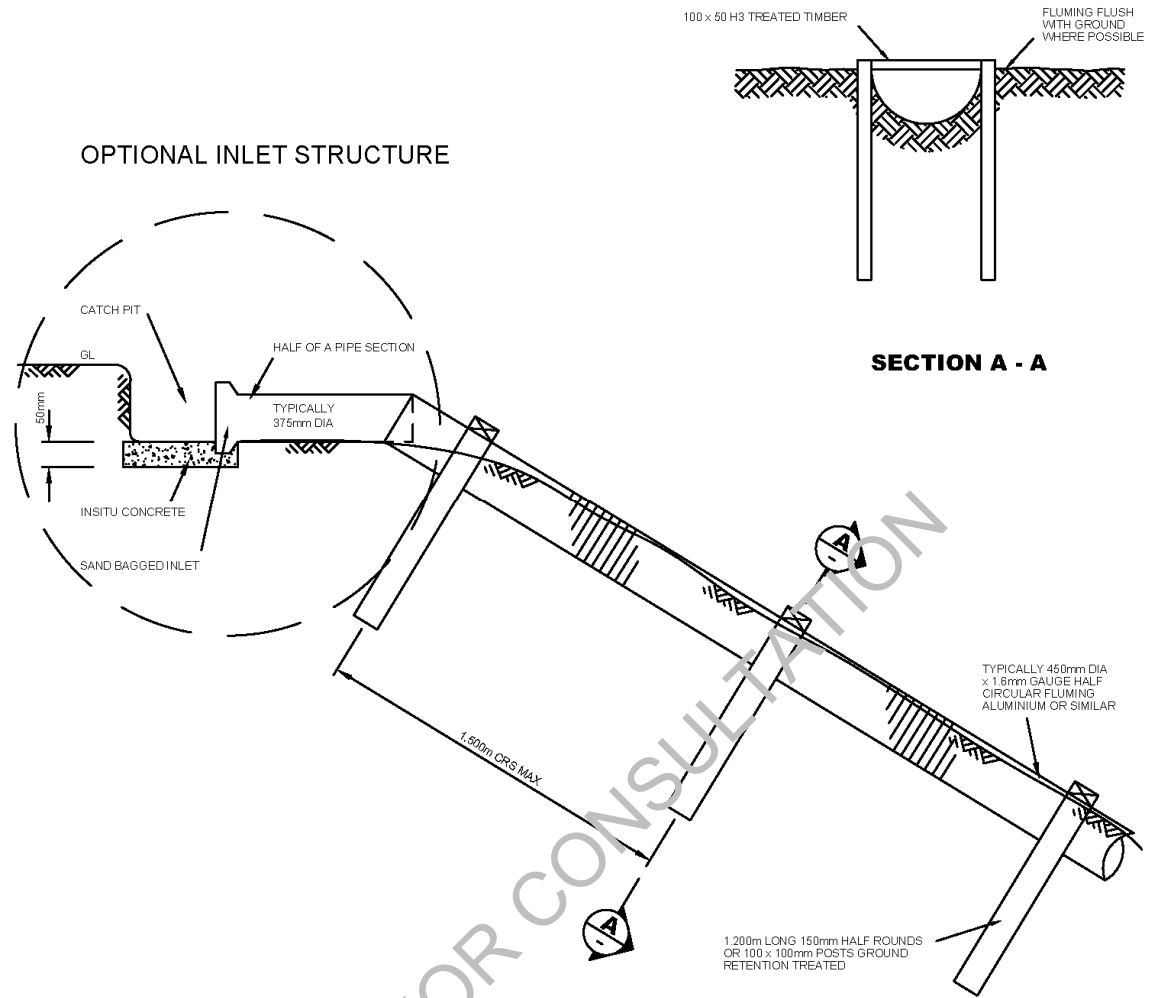

NOTES –

1. This reflects an in ground flume. An above ground support structure is another option.
2. On very steep gradients a splash cover should be considered.
3. For uneven or very steep banks an anti-scour sock can be considered.

**Figure 3.2b - Flume in ground**



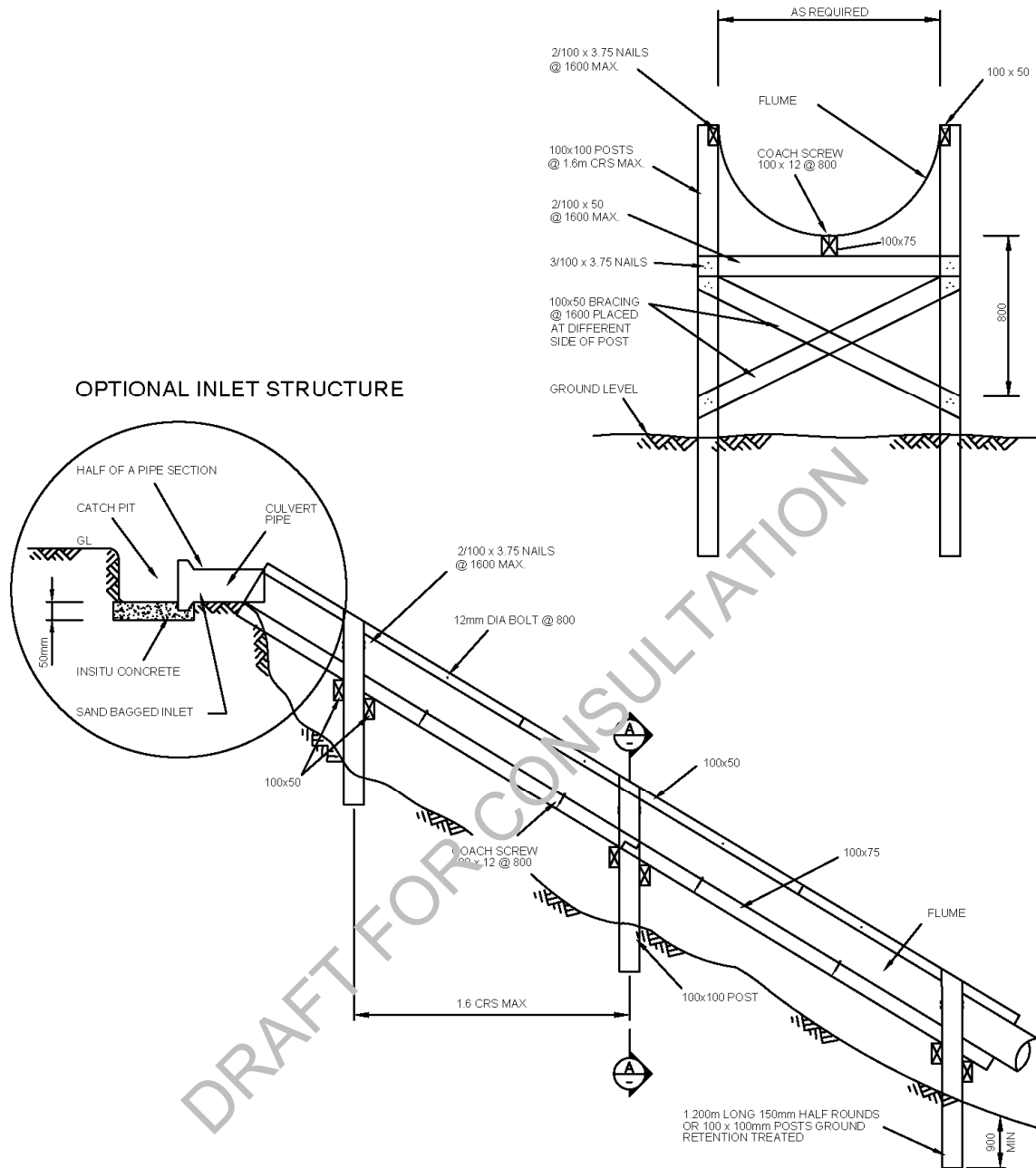

NOTES –

1. 100 x 50 bracing is only needed when the depth is more than 900mm.
2. On top, connection between flume is at different place of connection between post and 100 x 50 timber beam.
3. Flume diameter to be determined on site. Typically 1.6mm gauge half circular aluminium or UV resistant plastic.

Figure 3.2c – Flume out of ground

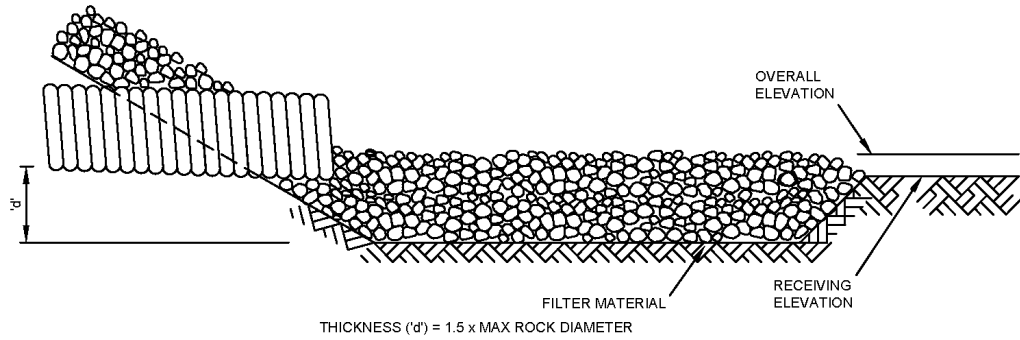

**SECTION**

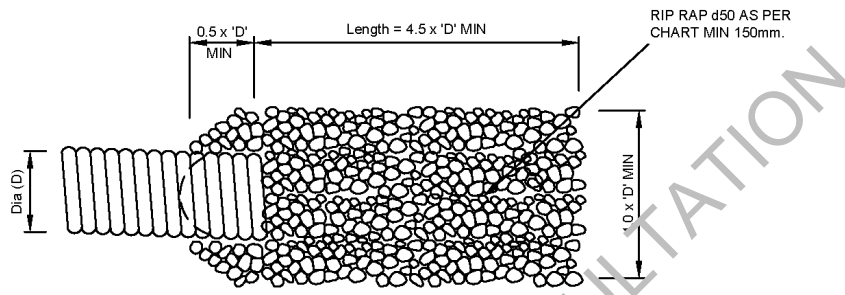

**PLAN**

**OUTLET PROTECTION**  
For a pipe flowing full with low tail water

**RIPRAP SIZE – D50 (mm)**  
**PIPE DIAMETER (MM)**

	300	375	450	525	600	675	750	900	1050	1200	1350	1500
85	100											
140	100											
220	125	100										
280	150	125	100									
340	200	150	150									
425	200	150	200	125								
480		200	200	125								
570		250	250	150	125							
710		300	300	150	150							
850				200	200	150						
1130				300	250	200	150					
1410				400	300	250	200	150				
1700				450	400	300	250	200				
1980					450	375	300	200				
2270					500	400	375	250	200			
2550						450	400	300	250			
2830						500	450	300	250			
3540						600	500	400	300	250		
4250							600	500	475	300	250	
5670								600	500	450	375	300

**NOTES –**

1. Apron shall be set at a zero grade and aligned straight.
2. Geotextile filter fabric beneath stone base on undisturbed soils or 150mm of 100mm metal free of fine clays, silts.

**Figure 3.2d - Energy dissipater**

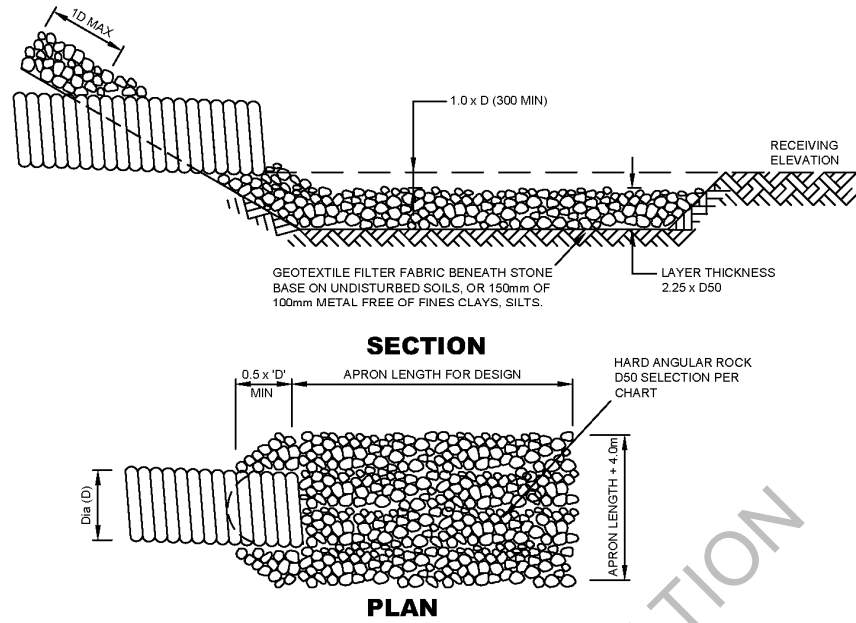

**OUTLET PROTECTION**  
For a pipe flowing full with low tail water  
**RIPRAP SIZE – D50 (mm)**  
**PIPE DIAMETER (MM)**

	300	375	450	525	600	675	750	900	1050	1200	1350	1500
85	100											
140	100											
220	125	100										
280	150	125	100									
340	200	150	150									
425	200	150	200	125								
480		200	200	125								
570		250	250	150	125							
710		300	300	150	150							
850				200	200	150						
1130				300	250	200	150					
1410				400	300	250	200	150				
1700				450	400	300	250	200				
1980					450	375	300	200				
2270					500	400	375	250	200			
2550						450	400	300	250			
2830						500	450	300	250			
3540						600	500	400	300	250		
4250							600	500	475	300	250	
5670								600	500	450	375	300

**MINIMUM LENGTH OF APRON (metres)**  
**PIPE DIAMETER (mm)**

	300	375	450	525	600	675	750	900	1050	1200	1350	1500
85	2.4											
140	2.4											
220	3.4	3.0										
280	4.3	3.7	3.0									
425	5.5	4.9	4.3	3.7								
570		5.5	5.5	4.9	3.7							
850			6.7	6.1	5.5	4.9						
1130			7.9	7.3	7.3	6.1	5.5					
1410				7.9	7.9	7.3	6.7	5.5				
1980					9.1	9.1	8.5	7.6				
2830						11.0	11.0	10.1	8.2			
4250						12.8	12.8	12.8	11.6	10.1	8.5	
5670								14.6	13.7	12.8	11.3	9.8

**NOTES -**

1. Consult with TRC if fish passage will be inhibited during low flows.
2. In defined channels, apron shall extend full width of bottom and 300mm above max. tail water or up to bank full, whichever is less.

**Figure 3.2e - Pipe outlet protection**

### 3.3.16 Private ways, private roads, and other private accesses

Access to all lots, dwellings, or multi-unit developments shall be considered at the time of subdivision/development and should where possible be formed at that time.

Where access to the lot is to a garage or car deck to be constructed as part of the buildings this shall be noted on the design drawings. This is likely to have been considered as part of the resource consent process.

Accesses shall be designed and constructed to the following requirements or in accordance with the TA's specific requirements, unless alternative designs by the developer's professional advisor are approved by the TA.

#### 3.3.16.1 Plan and gradient design

Table 3.2 should be used as a guide for the widths of elements required for accesses.

A maximum 3-point turning head in the common area shall be provided at the end of all accesses serving three or more rear lots or dwelling units. Circular, L, T, or Y shaped heads are acceptable. Suitable dimensions are shown in Figures 3.3 and 3.4.

For accesses serving fewer than three lots or dwelling units, turning heads in the common area are not required where it can be shown that adequate turning area is available within each lot or private area.

Centre line grades should:

- (a) Not be steeper than 1 in 5 although gradients of 1 in 4.5 may be used on straight lengths of access over distances of up to 20 m. The first 5 m of any access shall be not steeper than 1 in 8. A greater length of transition shall be provided where necessary on non-residential accesses;
- (b) Not be less than 1 in 250.

All accesses shall be shaped with either crown or crossfall of not less than 2%.

*Splays may be required for safety where right of ways connect with public roads at the discretion of the TA.*

To allow vehicles to pass, accesses shall have widening to not less than 5.5 m over a 15 m length at not more than 50 m spacing. Rural accesses may have passing bays at up to 100 m distances where visibility is available from bay to bay.

#### 3.3.16.2 Stormwater design

All shared urban accesses shall be surfaced and have their edges defined by a structural edge. The design shall demonstrate consideration of a sustainable approach to stormwater management rather than kerbed collection, channelling, and disposal, if possible.

Rural accesses shall be formed with safe water tables/edge drains along but adequately clear of each side of the access.

Accesses sloping up from the road shall have a stormwater collection system at the road reserve boundary so as to avoid stormwater run-off and debris migration onto the public road. Except in rural areas, stormwater shall discharge via an appropriately sized and designed stormwater system acceptable to the TA (see Figure 3.8 for examples of typical sump to driveway or right of way). Rural side drains may discharge directly to the roadside drain or where accesses pass over the side drain they shall be provided with a culvert of size appropriate for the design flow but not less than 300 mm diameter.

Accesses that slope down from the road shall be designed to ensure that road stormwater is not able to pass down the access. Side drainage in context with the area shall be provided to stop the concentration and discharge of stormwater and debris onto adjacent properties or any land which could be at risk of instability or erosion. Where an overland flow path departs from the road reserve, accesses shall be designed to direct secondary flow away from building floors and to follow designed overland flow paths.

Commercial and industrial accesses shall drain from their sumps through a lead directly or through a stormwater treatment device to a public stormwater main *if a stormwater connection has been approved by the TA - refer to clause 4.3.11 for details around the connection to the public system.*

**3.3.16.3 Pavement design**

Private pavements shall be designed as for public roads but no residential or rural pavement shall have a minimum formation thickness of less than 150 mm for flexible pavements or 100 mm for concrete pavements.

Commercial and industrial pavement shall be provided with adequate supporting design to ensure that it will have a life of 20 years.

Acceptable surfacing for accesses includes asphaltic concrete (25 mm minimum thickness), chip seals, in situ concrete or concrete pavers. *Also refer to Table 3.3 Recommended surfacing standards for more details.*

DRAFT FOR CONSULTATION

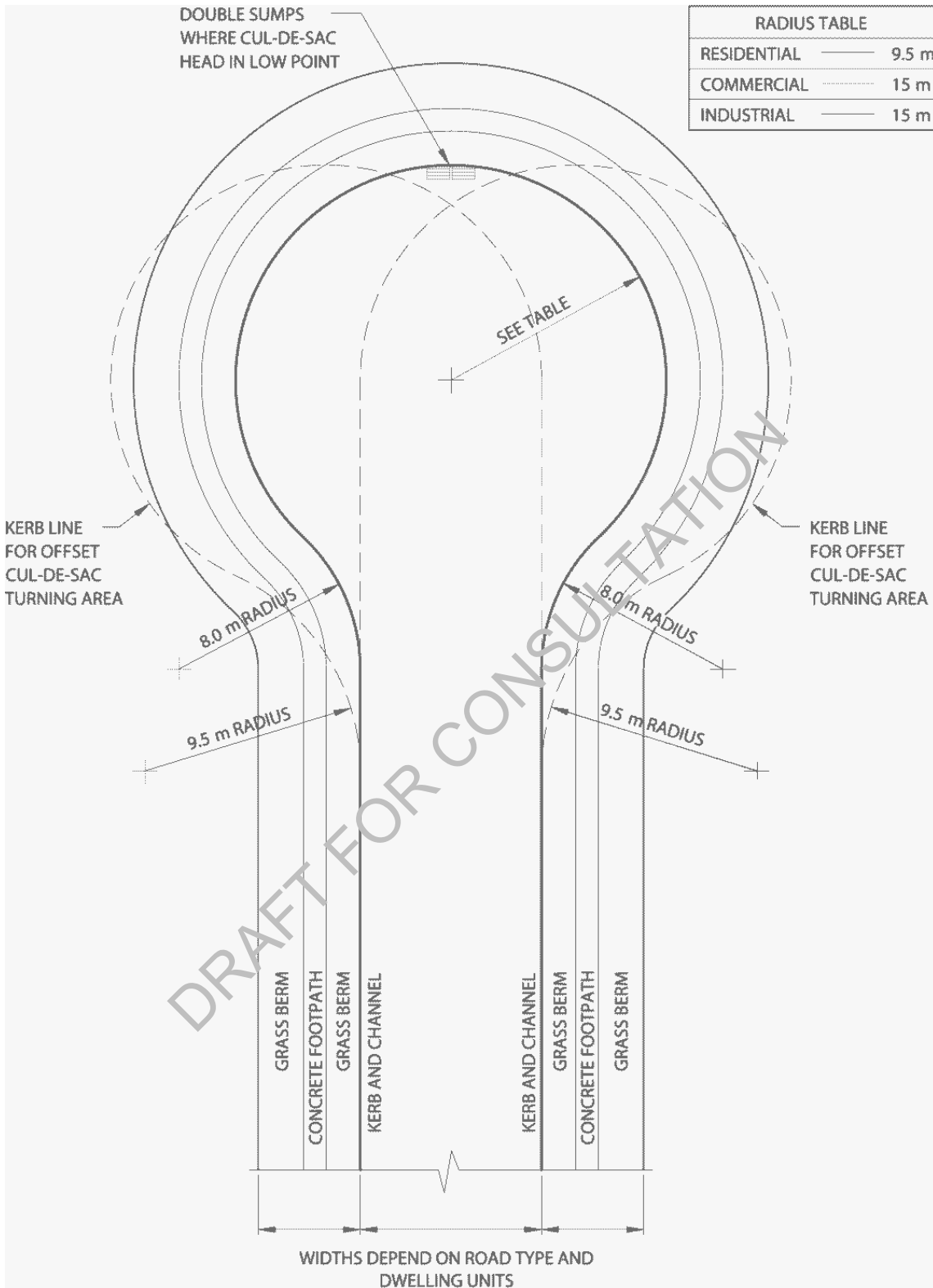
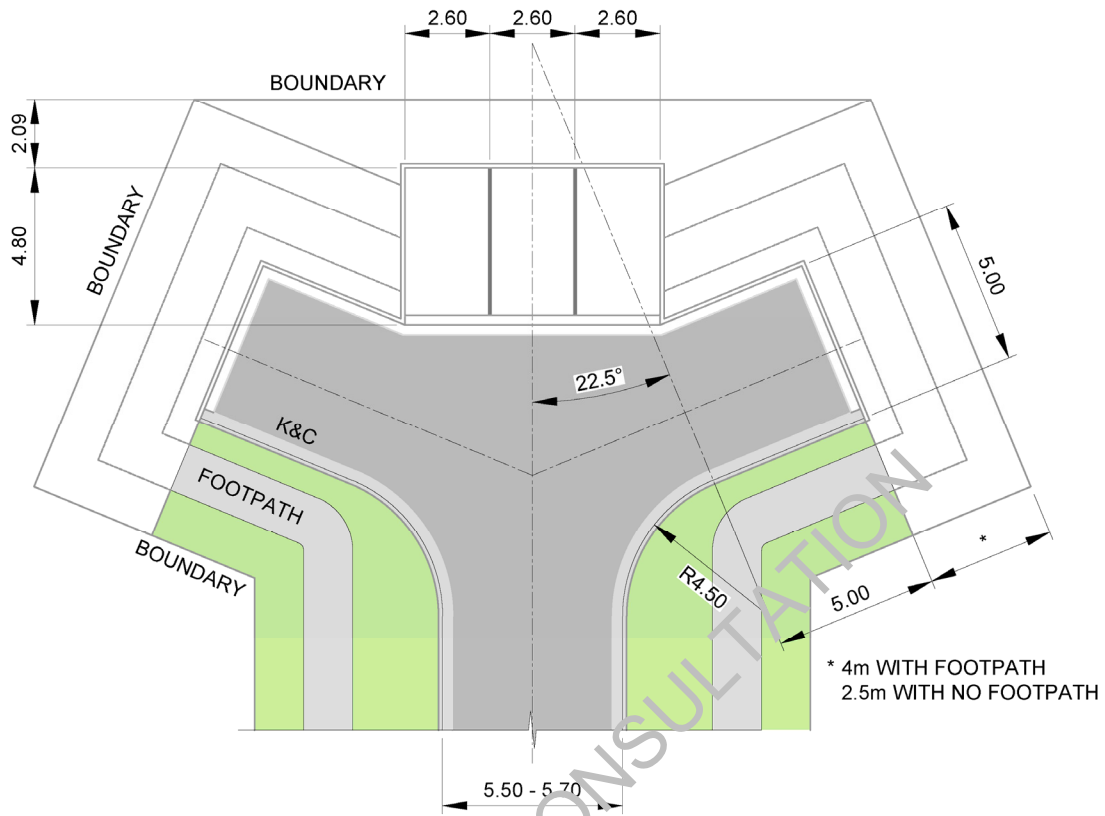

Figure 3.3 - Circular turning head: dimensions of no-exit road turning areas



NOTE –

Only for use where the standard circular head is unsuitable or where approved by the TA.

Figure 3.3a – Y Turning: dimensions of non-exit road turning areas

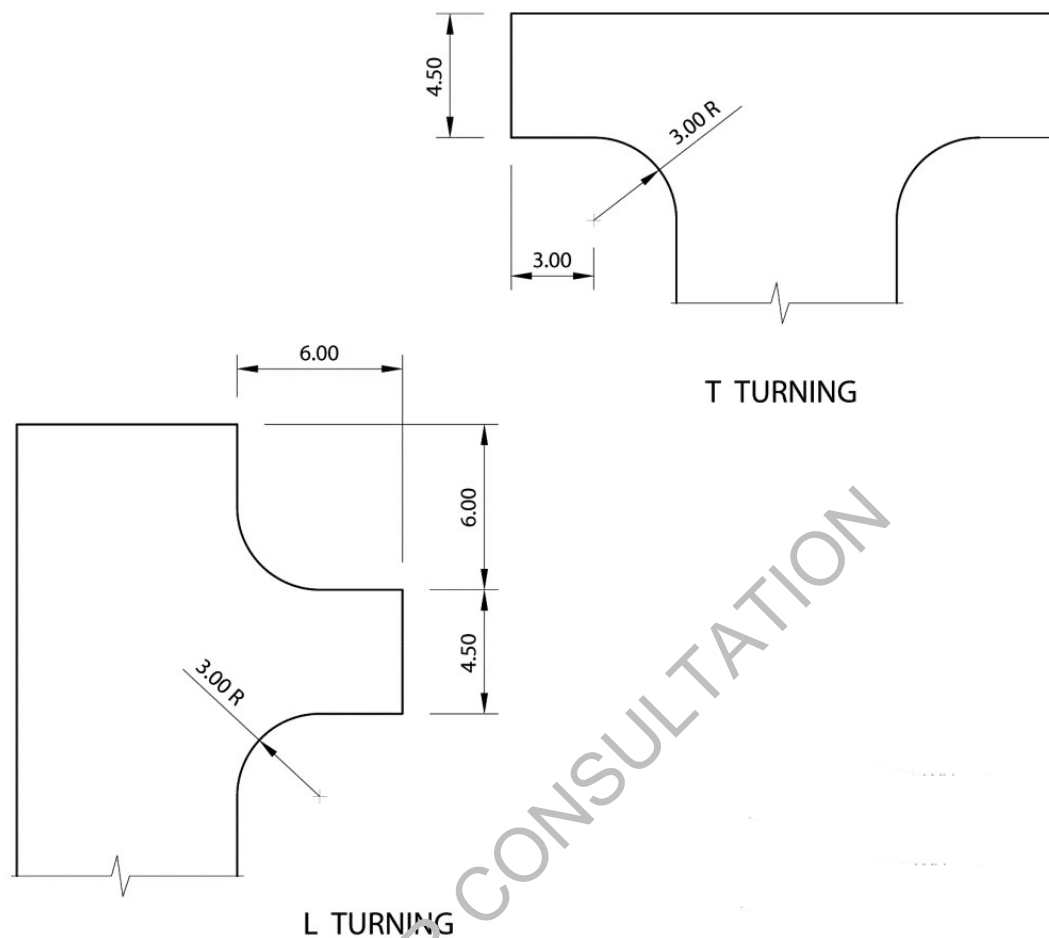

NOTE – All dimensions are in metres.

Figure 3.3b - Turning areas for private no-exit roads

### 3.3.17 Crossings

#### 3.3.17.1 Urban

Vehicle crossings shall be provided between the edge of the movement lane and the road boundary at the entrance to all private ways and lanes and to any lots, front or rear where access points are clearly identifiable at the subdivision or development stage.

Where access points are not clearly identifiable at the subdivision or development stage, crossings shall be constructed at the building consent stage.

Vehicle crossings shall be designed to enable the 90<sup>th</sup> percentile car to use them without grounding any part of the vehicle, and shall be designed in accordance with the NZTA *Pedestrian planning and design guide*. Figure 3.4f shows details satisfying this requirement. Structural design shall be adequate to carry the loads to be expected over its design life. All crossings shall be constructed with concrete or as approved by the Council.

Where stormwater drainage is provided by swale or open drain, crossings shall be provided as specified in 3.3.17.2.



Mobility crossings shall be provided at all road intersections. The crossings shall be sited to facilitate normal pedestrian movements in the road and where possible sumps shall be sited so as to reduce the flow of stormwater in the channel at the crossing entrance. Mobility and wheelchair crossings shall satisfy the NZTA *Pedestrian planning and design guide*.

*When the ADT on the street exceeds 5000vpd and/or traffic on the vehicle crossing exceeds 100vpd, a dish channel has to be provided at the channel as a minimum or an intersection type access be provided.*

*When turning movements at the vehicle crossing exceed 400vpd a deceleration lane or specific design has to be provided.*

*Figure 3.4 shows a mobility crossing.*

*Figure 3.4a shows the accepted detail of a standard urban crossing.*

*Figure 3.4b shows the accepted detail of an urban slot vehicle crossing.*

*Figure 3.4c shows the accepted detail of an urban plate vehicle crossing.*

*Figure 3.4d shows the cross sections of standard urban crossings.*

*Figure 3.4e shows the urban vehicle crossing widths for double garages.*

*Figure 3.4f shows maximum breakover angles for vehicular access to property.*

*Figure 3.4g shows rural vehicle crossings.*

DRAFT FOR CONSULTATION

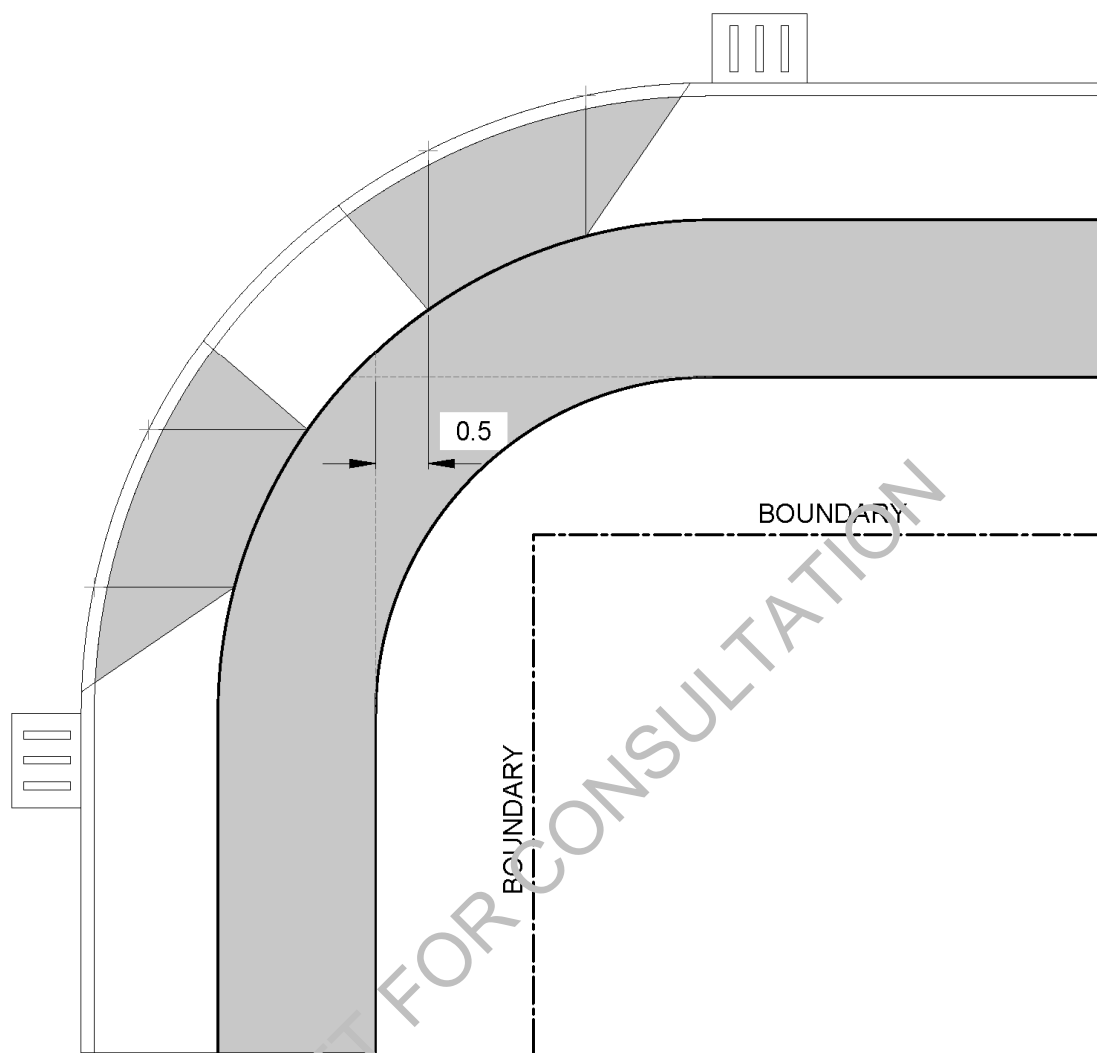

**NOTES –**

1. Mobility crossings to be constructed as per NZS4404:2010 with amendment 1, Section 3.3.17.1.
2. Tactile pavers as required by the TA.

**Figure 3.4 – Mobility crossing**

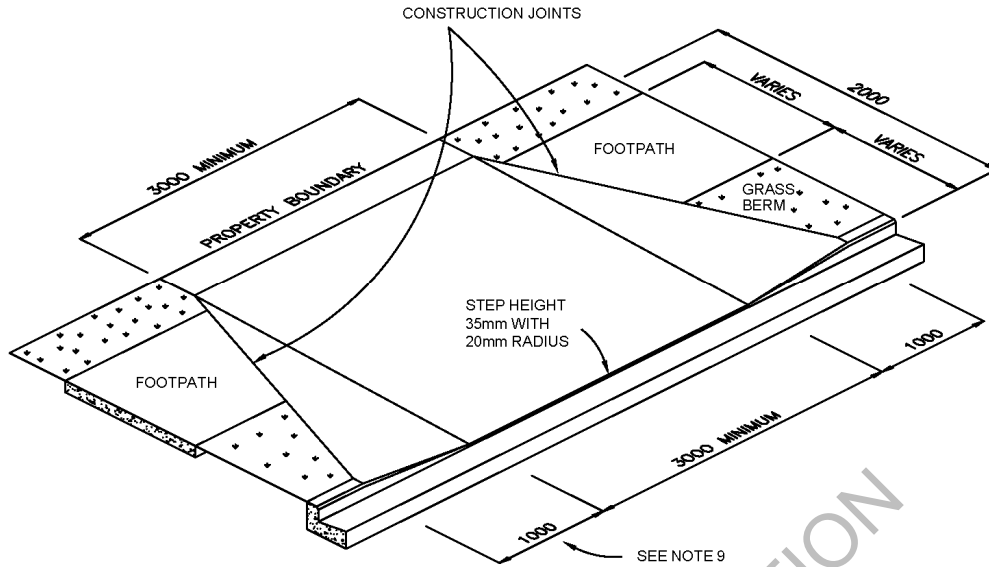

**NOTES -**

1. Construction joint required from any service boxes within crossing.
2. Concrete to be 20 MPa.
3. Residential crossing serving a single dwelling to be 100mm thick minimum in New Plymouth District and 125mm thick in South Taranaki District.
4. Commercial/light industrial/multi-residential crossings to be 150mm thick with HRC 665 reinforcing steel mesh placed mid-depth within the concrete pad in New Plymouth District only. Crossings shall also have three D12 rods in dished kerb and channel.
5. Heavy industrial crossings to be 200mm thick with five D12 rods in dished kerb and channel with HRC 665 reinforcing steel mesh shall then be placed mid-depth within the concrete pad.
6. Concrete finish to NZS 3114 U5 (hard or soft bristle broom).
7. All weak subgrade ground conditions are to be removed and replaced with AP40 compacted granular material to achieve designed subgrade level.
8. On the engineer's approval, the spray for heavy industrial crossings may be increased sufficiently to ensure all vehicle movements in/out of the private property do not cross the existing carriageway centreline.
9. All broken concrete edges to be sawcut.
10. Wing dimensions shall be 1000mm in New Plymouth District and 500mm in South Taranaki District.

**Figure 3.4a - Standard urban vehicle crossing**

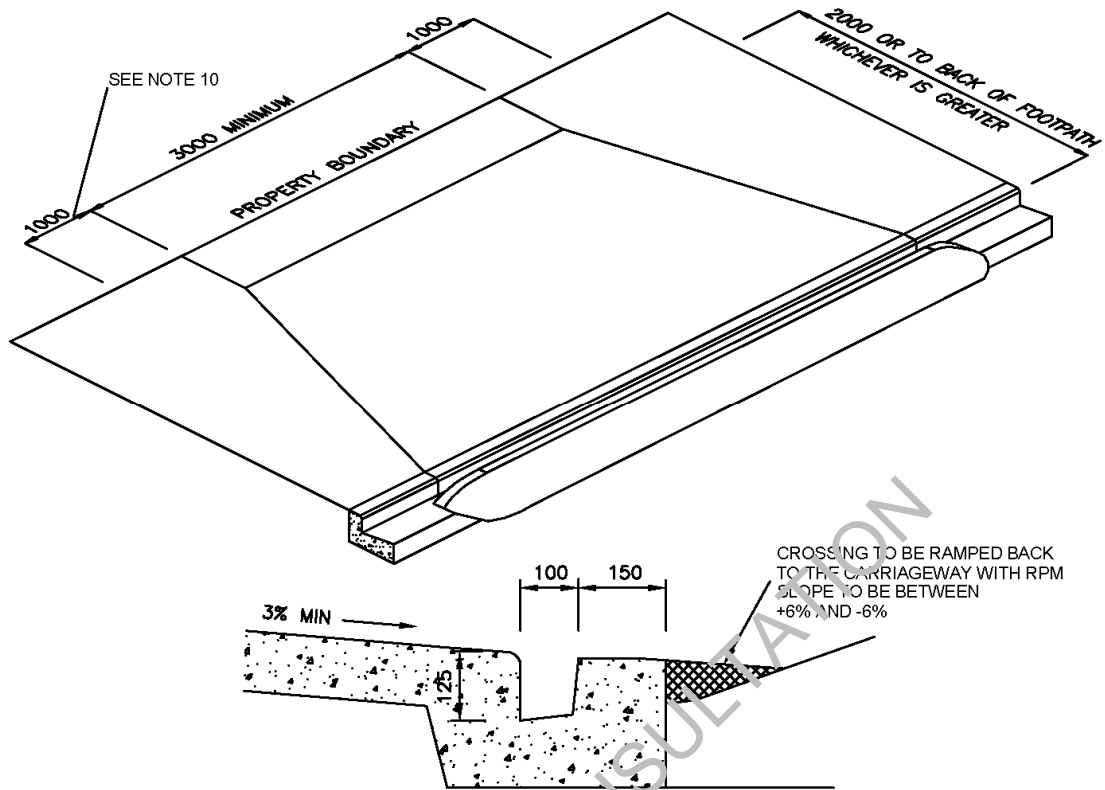

**Figure 3.4b - Urban slot vehicle crossing**

See notes on Figure 3.4a

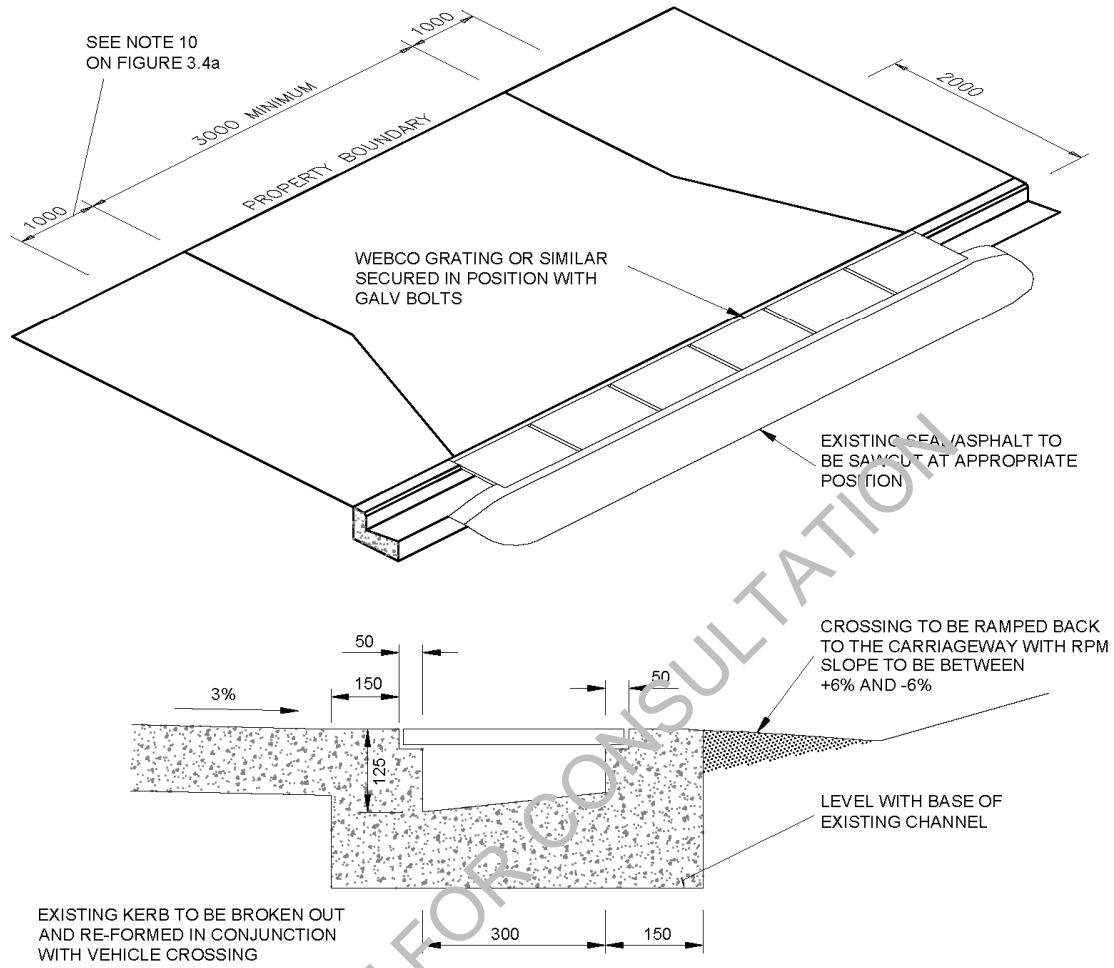

**Figure 3.4c - Urban plate vehicle crossing**

See notes on Figure 3.4a

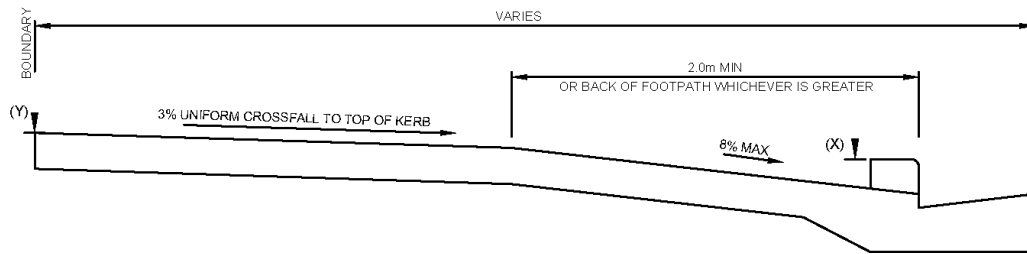

### 1. STANDARD CROSS SECTION

1. THE LEVEL AT THE BOUNDARY (Y) SHALL BE DETERMINED BY A LINE RISING AT 3% FROM THE NOMINAL TOP OF KERB LEVEL (X).

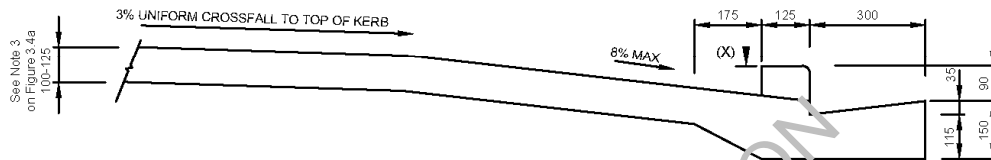

### 2. DETAIL OF SINGLE RESIDENTIAL CROSSING



### 3. MULTI RESIDENTIAL CROSSING

REINFORCING= 3x D12 BARS (NPDC ONLY) PLUS 665 MESH, 75mm COVER  
Refer to Note 4 on Figure 3.4a

#### NOTES -

##### Vehicle crossing details:

1. A maximum driveway gradient of 20% is permitted for up to 2.0m inside the property boundary.
2. Where the topography does not permit a crossing within the limits, it will normally be necessary to undertake additional works within the property.

##### Figure 3.4d - Standard urban vehicle crossing detail

See notes on Figure 3.4a

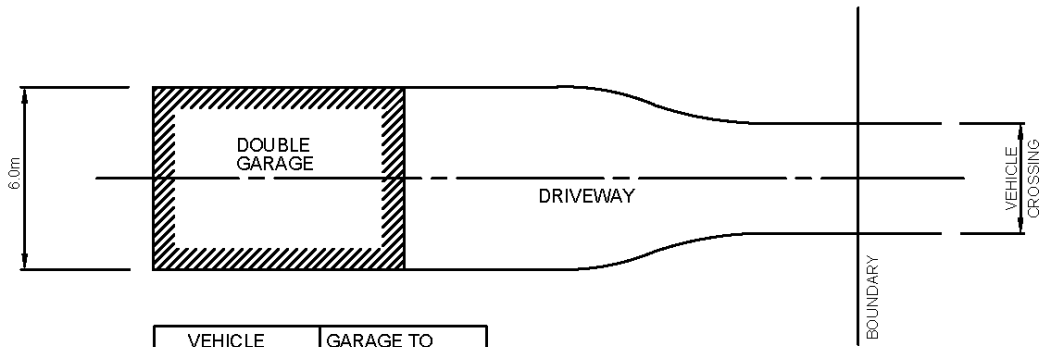

VEHICLE CROSSING WIDTH	GARAGE TO BOUNDARY DIST. (m)
3.0m	12.0m →
4.0m	10.0 - 12.0
5.0m	8.0 - 10.0
6.0m	0.0 - 8.0

## CENTRAL DRIVEWAY

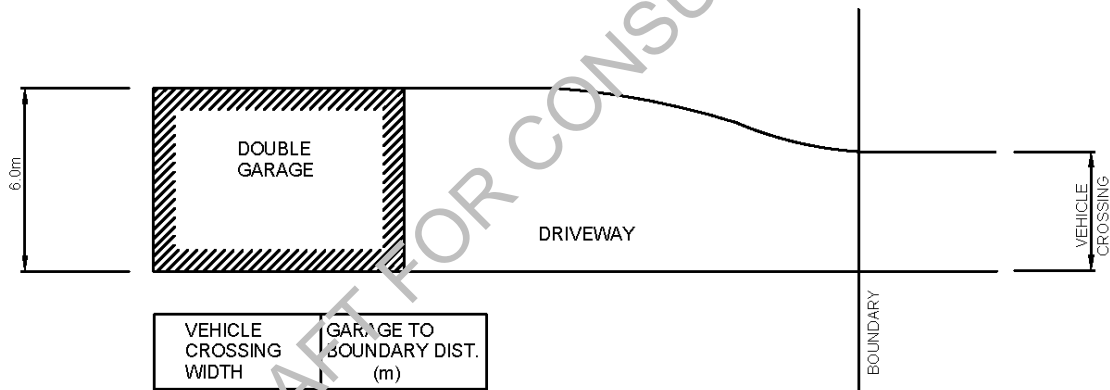

VEHICLE CROSSING WIDTH	GARAGE TO BOUNDARY DIST. (m)
3.0m	14.0m →
4.0m	11.0 - 14.0
5.0m	10.0 - 11.0
6.0m	0.0 - 10.0

## OFFSET DRIVEWAY

Figure 3.4e - Urban vehicle crossings for double garages

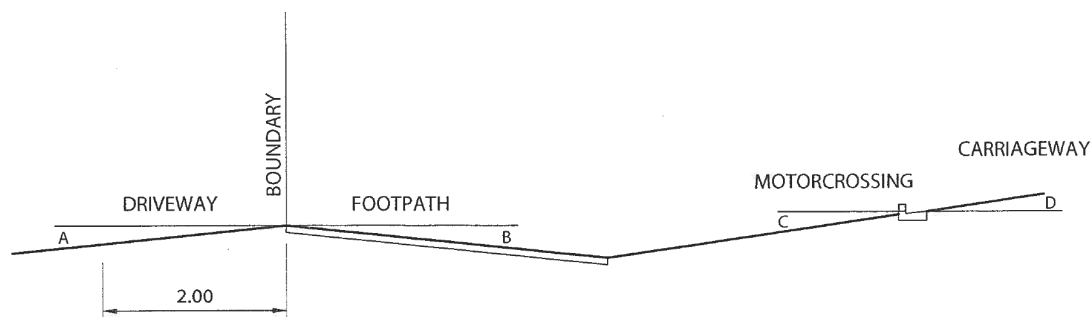

MAXIMUM CHANGE OF GRADE:  $A + B \leq 10\%$  (or  $5.7^\circ$ )  
 $C - D \leq 10\%$  (or  $5.7^\circ$ )  
 $B + C \leq 17\%$  (or  $9.6^\circ$ )

### LOW LEVEL FOOTPATH

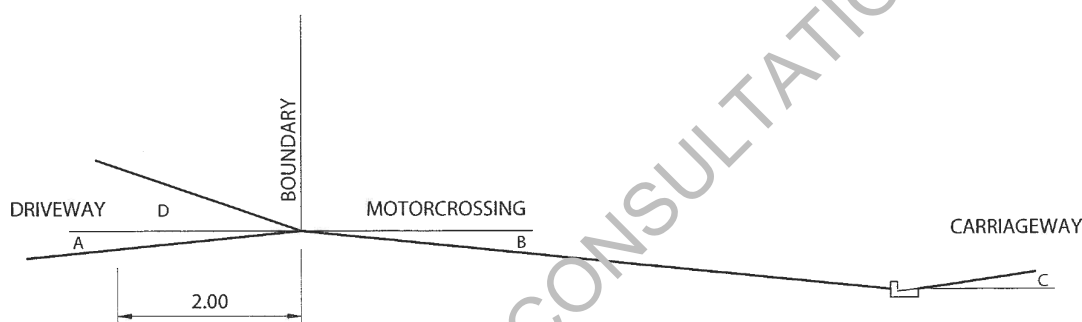

MAXIMUM CHANGE OF GRADE:  $A + B \leq 10\%$  (or  $5.7^\circ$ )  
 $D - B \leq 17\%$  (or  $9.6^\circ$ )  
 $B + C \leq 17\%$  (or  $9.6^\circ$ )

### STANDARD FOOTPATH

#### NOTES –

1. A, B, C and D refer to the gradients expressed either as a percentage or in degrees.
2. Low slung cars with ground effect features may not meet the criteria assumed in this design guide.
3. LTSA document *Light Vehicle Sizes and Dimensions: Street Survey Results and Parking Space Requirements – Road and Traffic Standards Information No. 35 (June 1994)* contains more information about the 90<sup>th</sup> and 99<sup>th</sup> percentile vehicles.
4. Buses are permitted lower clearance value of (A+B) of 6% or  $3.4^\circ$ .

BASED ON 90<sup>TH</sup> PERCENTILE CAR AS AT 1990.

**Figure 3.4f - Maximum breakover angles for vehicular access to property**



**3.3.17.2 Rural**

*All shared crossings in the South Taranaki District shall be installed at the time of subdivision, unless otherwise approved by the TA. Other crossings shall be installed at the building consent stage.*

*All right of ways in the New Plymouth and Stratford districts and anywhere the location is obvious at the design stage shall be installed at the time of subdivision. Other crossings shall be installed at the building consent stage.*

Crossings shall be provided between the surfaced road edge and the lot boundary at a defined and formed access point to every rural lot. The crossing shall be sealed to not less than the standard of the road surface and to the road boundary. If the access slopes up from the road the crossing shall be sealed to a minimum distance of 6 m from the edge of the carriageway *in accordance with Figure 3.4g.*

The crossing shall not obstruct the side drain. Where the side drain is shallow and only carries small flows during rain, the crossing may pass through the side drain. Where the side drain is of an unsuitable shape or carries flows for significant parts of the year the side drain shall be piped under the crossing. Pipes and end treatments shall be sized appropriately for the catchment intercepted but shall be a minimum of 300 mm diameter.

Rural crossings shall be designed so that vertical curvature transitions are suitable for the passage of the 90<sup>th</sup> percentile car and control of stormwater and debris run-off.

*Figure 3.4g shows the accepted detail of a rural vehicle crossing.*

DRAFT FOR CONSULTATION

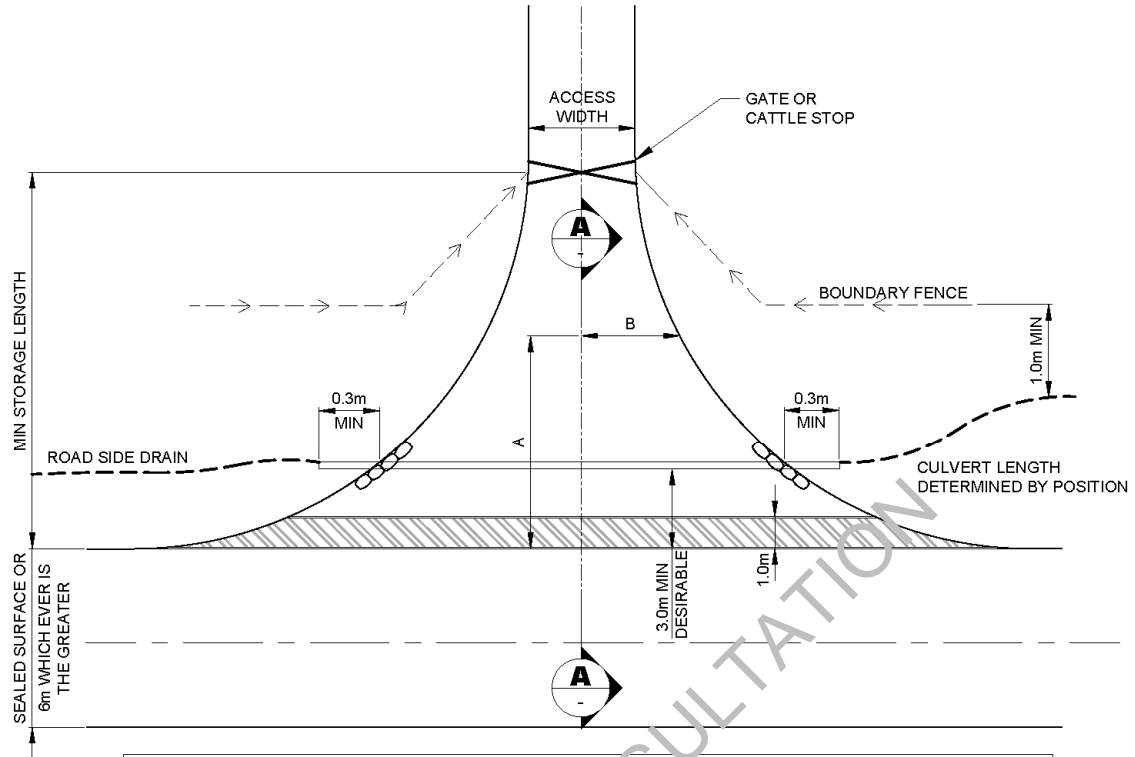

	DIMENSIONS AND SETOUT TABLE					
	TYPE F URBAN RESIDENTIAL OR RURAL FIELD CROSSING		TYPE G RURAL RESIDENTIAL OR MEDIUM SERVICE		TYPE H TANKER OR HEAVY SERVICE	
ACCESS WIDTH (MIN)	3.0m		3.6m		4.0m	
STORAGE LENGTH OF GATE SETBACK (MIN)	6.0m		6.0m		15.0m	
RADIUS R (MIN)	4.0m		6.0m		15.0m	
CURVE SETTING OUT DETAIL (MIN)	A	B	A	B	A	B
	0.00	5.50	0.00	7.80	0.00	17.00
	2.00	2.04	2.00	3.33	5.00	5.82
	4.00	1.50	4.00	2.14	10.00	2.86
			6.00	1.80	15.00	2.00

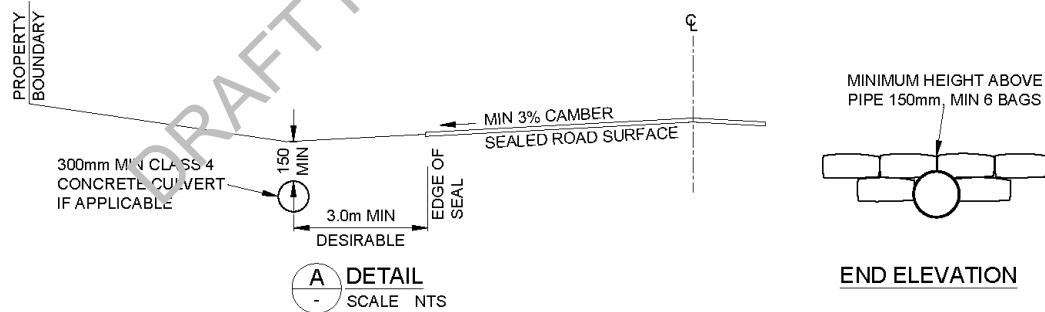

**NOTES –**

1. Culvert ends to be protected by a head wall or concrete filled bags splayed to match the radius and depth as shown in end elevation.
2. Shaded area to be constructed with 200mm (min depth) basecourse remainder of entrance to be constructed with 150mm (min depth) basecourse. The entire crossings shall be sealed with a two coat chipseal. These are minimum requirements. Site specified design may be required.
3. All fencelines must be set back a minimum of 1.5m from any width indicated in the table.

**Figure 3.4g - Rural vehicle crossings**

### 3.3.18 Fencing

Fencing shall be provided along the road reserve boundaries of all rural subdivisions unless agreed otherwise by the TA. Standards and requirements shall be in accordance with the TA's fencing policy at the time. This shall also apply to fencing of pedestrian, cycle, and reserve accesses in rural areas.

### 3.3.19 Road run-off

#### 3.3.19.1 Integration of road run-off with development stormwater system

Stormwater management for a subdivision needs to integrate the control of stormwater from the proposed roading network with the overall stormwater system for the land development phase and final subdivision layout. Such planning needs to integrate the control of stormwater peak flows and pollutant removal as set out in section 4 of this Standard with the aim of minimising downstream negative effects and mitigating road instability and erosion problems. Some guidance on integrated catchment management is set out in NZTA *Stormwater treatment standard for state highway infrastructure*.

#### 3.3.19.2 Design

For stormwater run-off design see section 4 of this Standard.

#### 3.3.19.2.1 Minimum size of Drainage Pipes in Rural Areas

*Roading drainage pipes and culverts shall be concrete and shall meet the following minimum sizing requirements:*

- 375 mm internal diameter for road drainage in New Plymouth District
- 300 mm internal diameter for road drainage in South Taranaki District
- 300 mm diameter under vehicle crossings

#### 3.3.19.3 Subsurface drains

Where considered necessary by the TA or the developer's professional advisor, piped subsurface drainage shall be provided to protect road formations from deterioration or loss of strength caused by a high water table and as part of swale stormwater systems. Design shall be in accordance with NZTA specification F/2.

Piped subsurface drains shall be provided on each side of all urban roads where the natural subsoils have inadequate permeability or unacceptably high water table to enable long term strength of the new pavement to be maintained. Piped subsurface drains shall be provided on the upslope side of all urban roads in hill areas and on the down side also where the down slope is in cut.

All piped subsurface drains shall discharge by gravity into a suitable component of the public stormwater system or approved discharge point.

For two typical details of under-kerb drainage and subsoil drainage see Figure 3.5.

#### 3.3.19.4 Side drains/water tables

Rural roads shall have normal camber (see Tables 3.2 and 3.2a) to side drains/water tables formed on each side of the carriageway except where the road is on embankment above adjacent land without available formed drains. In such cases the road may be designed so as to provide for sheet run-off to the adjacent land surface provided natural pre-existing drainage patterns are not altered.

For all situations where side drains are required they shall be sized to suit the flows discharging to them. Side drains shall be intercepted at regular intervals and discharge via open drains or pipes to an appropriate discharge point. All discharge points shall have outlets protected from scour and shall be located to minimise the risk of slope instability.

Such discharges shall be subject to the approval of affected property owners and be shown to be neither diverting catchments nor significantly changing peak flows or flow patterns.

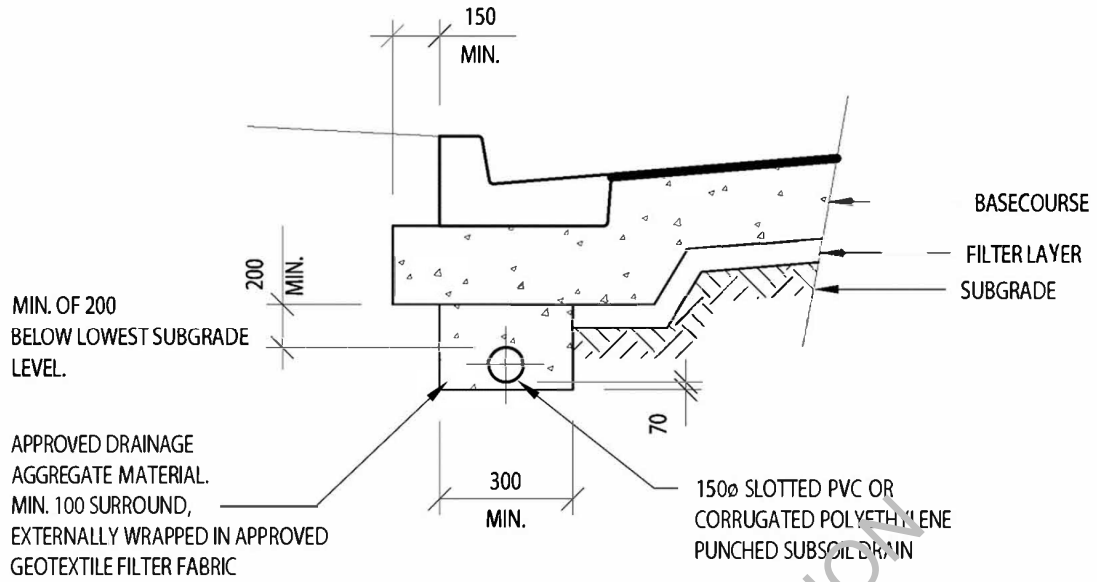

UNDER KERB DRAINAGE

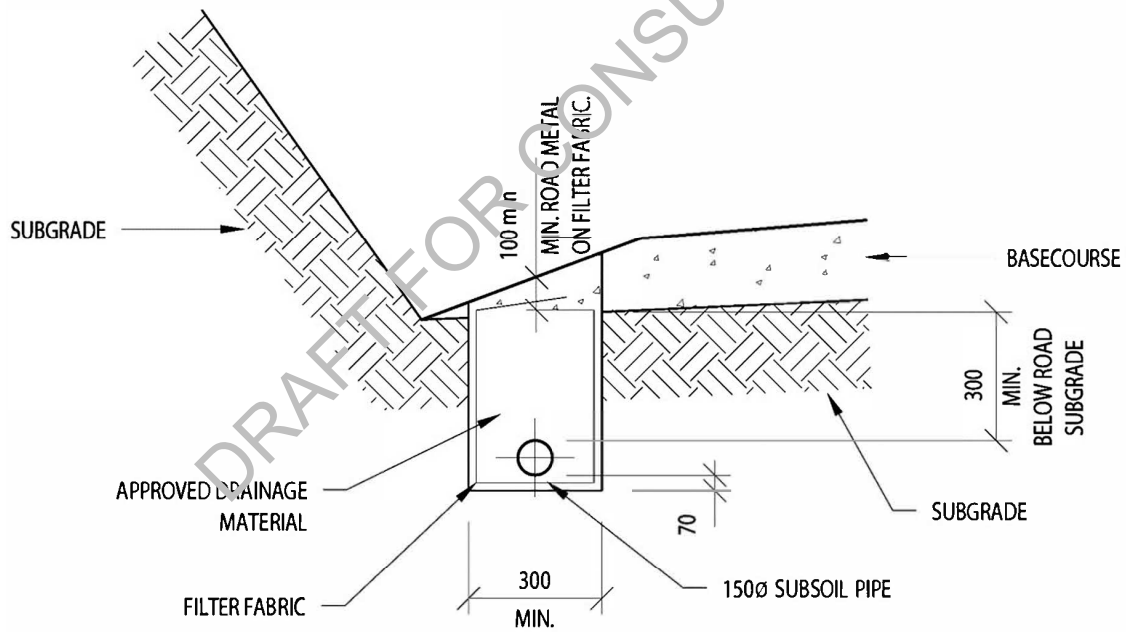

SUBSOIL DRAINAGE

All dimensions are in millimetres.

Figure 3.5 - Subsoil drains

**3.3.19.5 Swales**

Swales should be used wherever appropriate to allow for infiltration to reduce peak discharge flows and to provide stormwater treatment. They can be located either in the berm area or in the centre of the road, and must be of sufficient width to accommodate services (if needed), plant growth and maintenance (see 7.3.5).

Where swales are used they shall be designed by a suitably qualified person in accordance with TA requirements. *Typical details that may be used in swale design are shown in Figure 3.6. Further information to be discussed with the relevant TA can be found in Christchurch City Council's Rain Garden Design, Construction and Maintenance Manual, May 2016.*

See 4.3.7.6 for swale design and section 7 on landscaping design and practice.

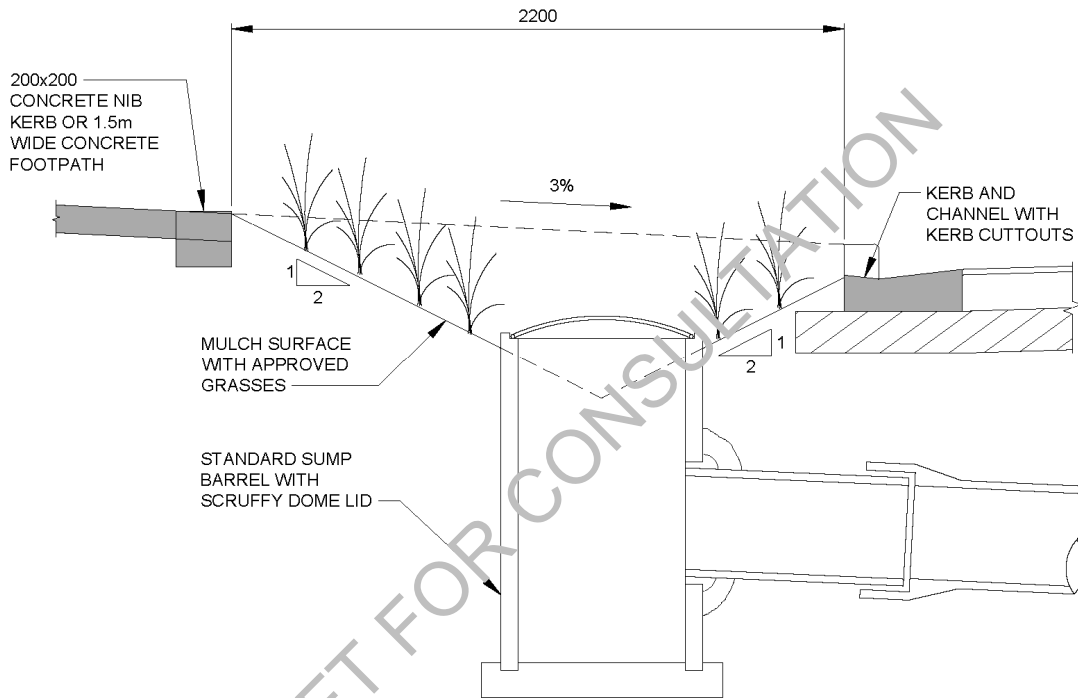

**NOTES –**

1. Effective catchment area drained = impervious area + 0.72 x pervious area.
2. To be sized for conveyance of 10% AEP event.
3. Existing ground is regraded, compacted, topsoiled (100mm depth) and grassed.

**Figure 3.6 – Swale cross section – urban design (for reticulated systems only)**

**3.3.19.6 Kerbs and channels**

Where kerbs and channels are to be provided on carriageways they should comply with Figure 3.7. Mountable or nib kerbs, or their slip-formed equivalent may be used subject to the approval of the TA. Mobility crossings should be provided for disability access at regular intervals and at locations where pedestrians are reasonably expected to transition between footpaths and the street.

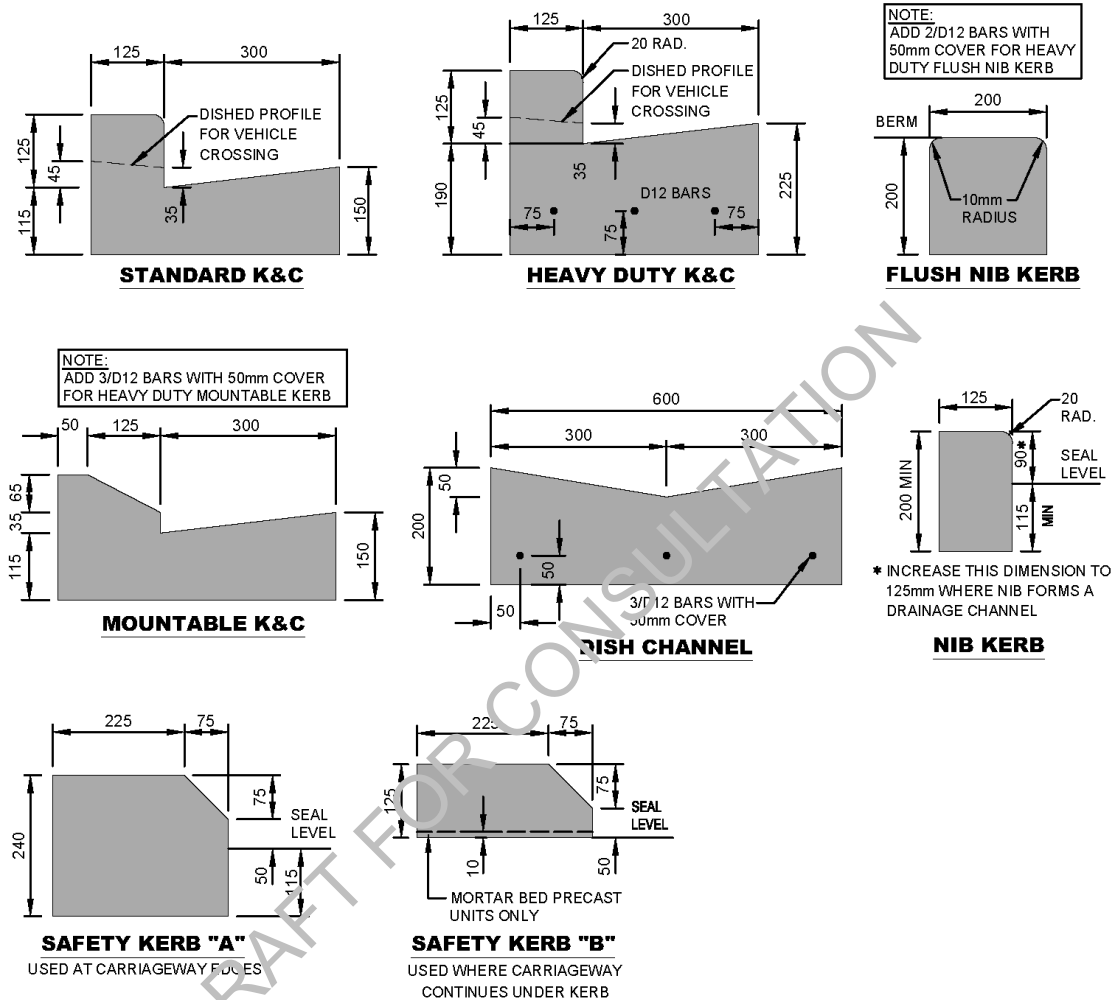

**NOTES –**

1. All concrete shall be 20 MPa ready-mixed.
2. Heavy duty kerb and channel shall be used for all radius kerb at intersections and elsewhere as required by the Code of Practice, or as directed by the TA.
3. The minimum width for wheelchair crossing dishes shall be 1.5m with a transition to adjacent kerb over 1.0m each side. Wider crossings shall be used where the footpath intersects the kerb at a sharp angle.
4. The layout of footpath and mobility crossings at intersections shall be determined to suit each case and will be subject to specific approval.

**Figure 3.7 - Kerbs and dished channels**

**3.3.19.7 Sumps**

Sumps used in all public places shall comply with the TA's current standard details.

Stormwater sumps are classified as three types according to the design of their inlets:

- (a) Grated only inlet sumps: Grated inlets are effective in intercepting gutter flows. They also provide access openings for maintenance. Grated inlets are prone to blockage and problems of increased pavement maintenance in the immediate vicinity of the inlet, therefore, their use in street gutters are discouraged. They are suitable for non-kerbed situations such as yards, end of ditches, open car parks, accessways, driveways, medians, and ponding areas. Figures 3.8 and 3.9 show details of common types of grated inlet;
- (b) Back entry inlet sumps: Back entry inlets are less affected by blockage, and they are more effective in intercepting flows in sag areas;
- (c) Combined grates and back entry inlet sumps: This system of combining a back entry with the traditional grated inlet significantly improves flow intake and is less prone to blockage from debris. This type of inlet should be used in all situations where possible. Figures 3.10 to 3.14 show typical examples of this type of inlet.

Figure 3.8 shows an acceptable detail for sumps in accessways, footpaths, and rights of way. A flat channel or yard sump and various styles of hillside sump are shown in Figures 3.9, 3.10, 3.11, 3.12, and 3.13.

A double back-entry sump for road low points is shown in Figure 3.14.

With different dimensions for a standard kerb and a mountable kerb, the vertical alignment of the top of kerb and kerb face horizontal alignment has to be maintained across the sump. Sumps with a mountable kerb shall be constructed in accordance to Figure 3.10.

**3.3.19.7.1 Sump location**

Sumps shall be located:

- (a) To ensure that the total system design flow enters the pipe system and that surface flows across intersections are minimised. In hill areas the total design flow shall include run-off from any upslope hillsides that are not specifically drained. In many cases this will mean the use of closely spaced or specially designed sumps to ensure that the flow to which the pipe system is designed can actually get into the system;
- (b) At all points in a surface system where a change in gradient is liable to result in ponding due to change in flow velocities or on bends where there may be a tendency for water to leave the kerb and channel;
- (c) Not further apart than 90 m along any surface system.

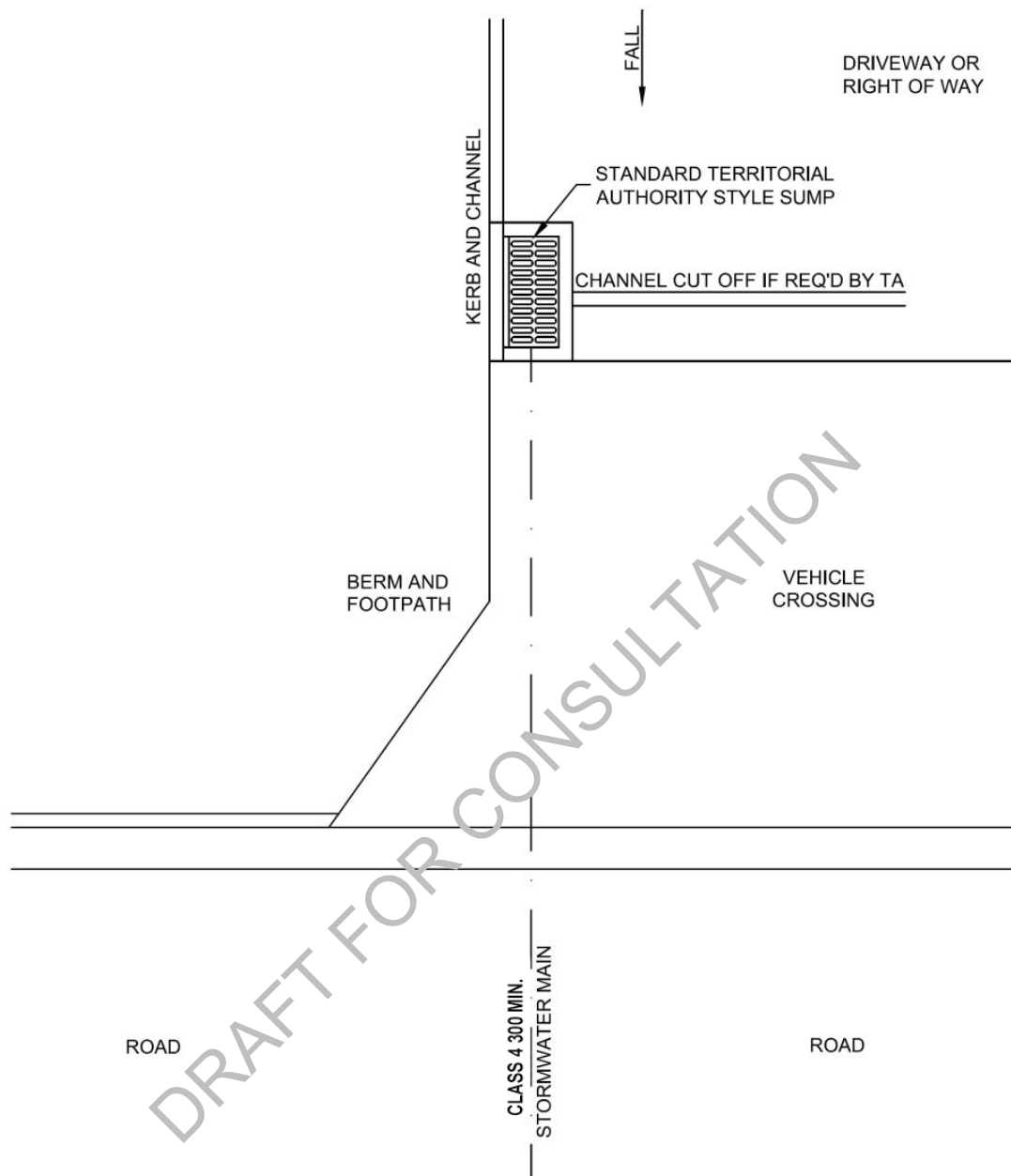

NOTES –

1. All dimensions are in millimetres.
2. Disposal of stormwater to soak holes or connection to public drain if approved by the TA (refer clause 4.3.11).
3. Class 4 pipe to be used as minimum. Higher rating classes may be required depending on conditions and cover of pipe.

**Figure 3.8 - Typical sump to driveway or right of way**



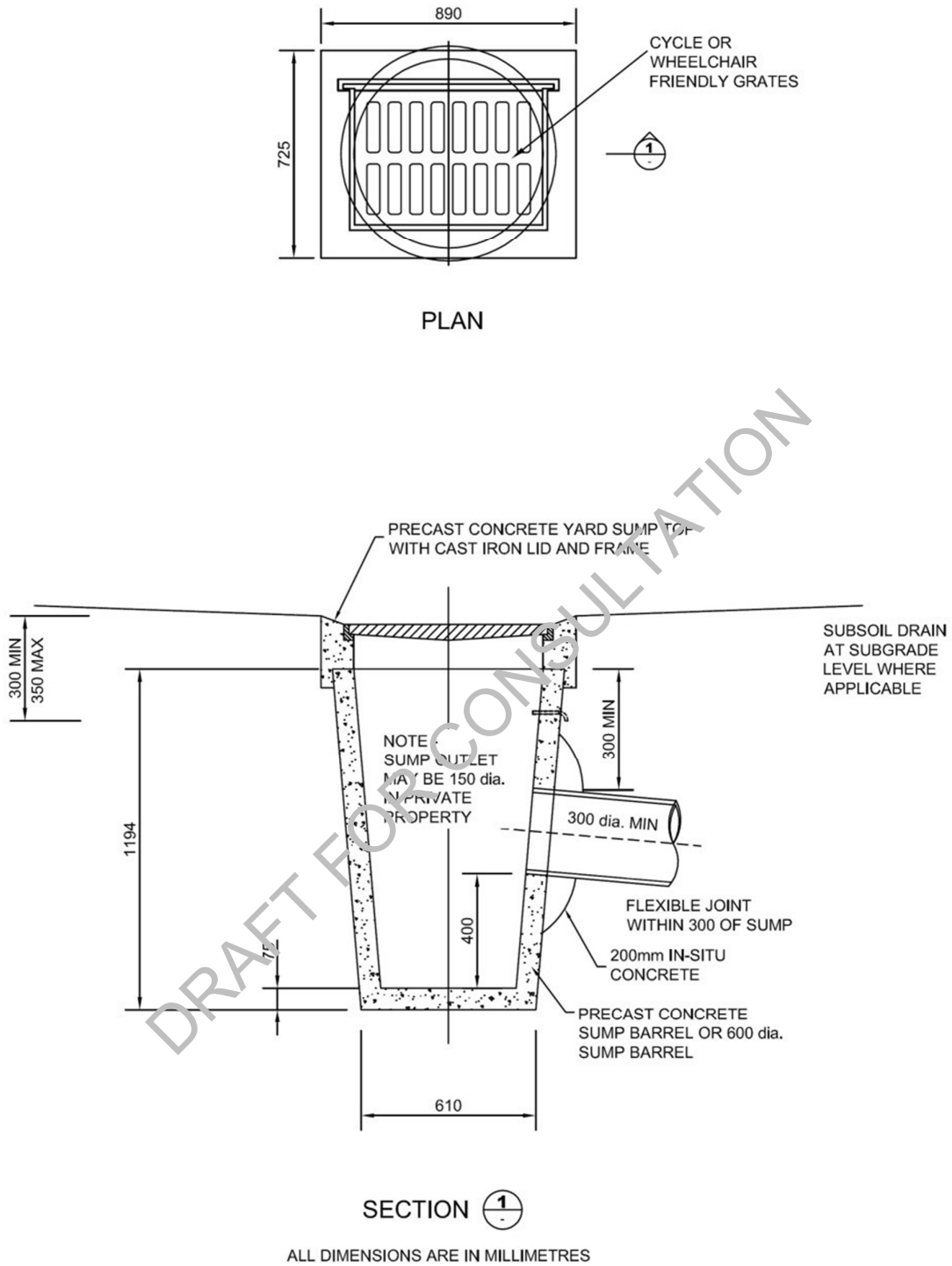
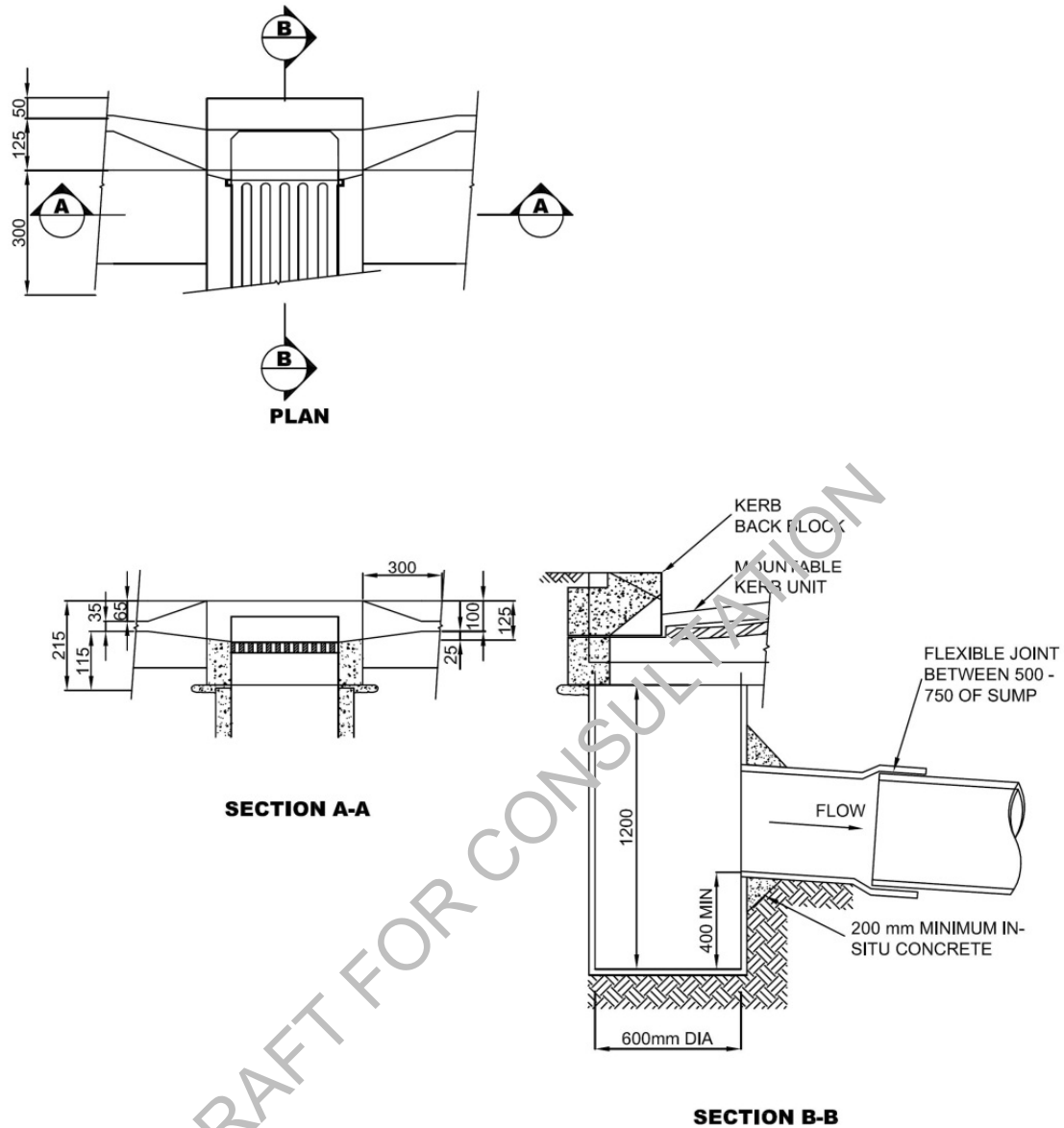

Figure 3.9 - Flat channel or yard sump



**NOTES –**

1. Tilt sump cover, grade and back block to the back to make up for height difference between standard and mountable kerb.
2. Kerb top vertical alignment and kerb face horizontal alignment is to be maintained across the sump.
3. Dimensions on the drawing are for a standard mountable kerb and channel.

**Figure 3.10 - Mountable kerb sump and grate detail**

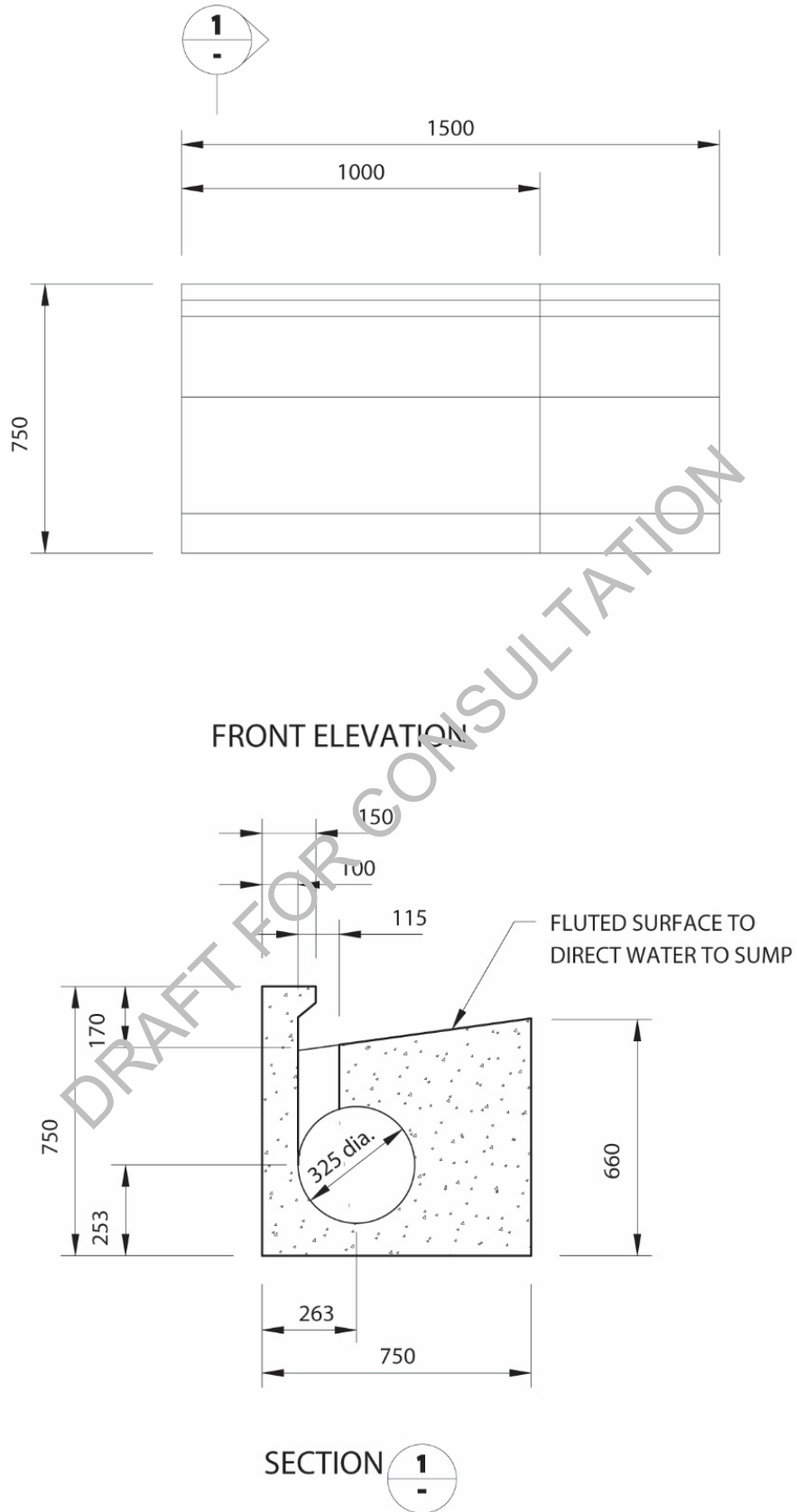
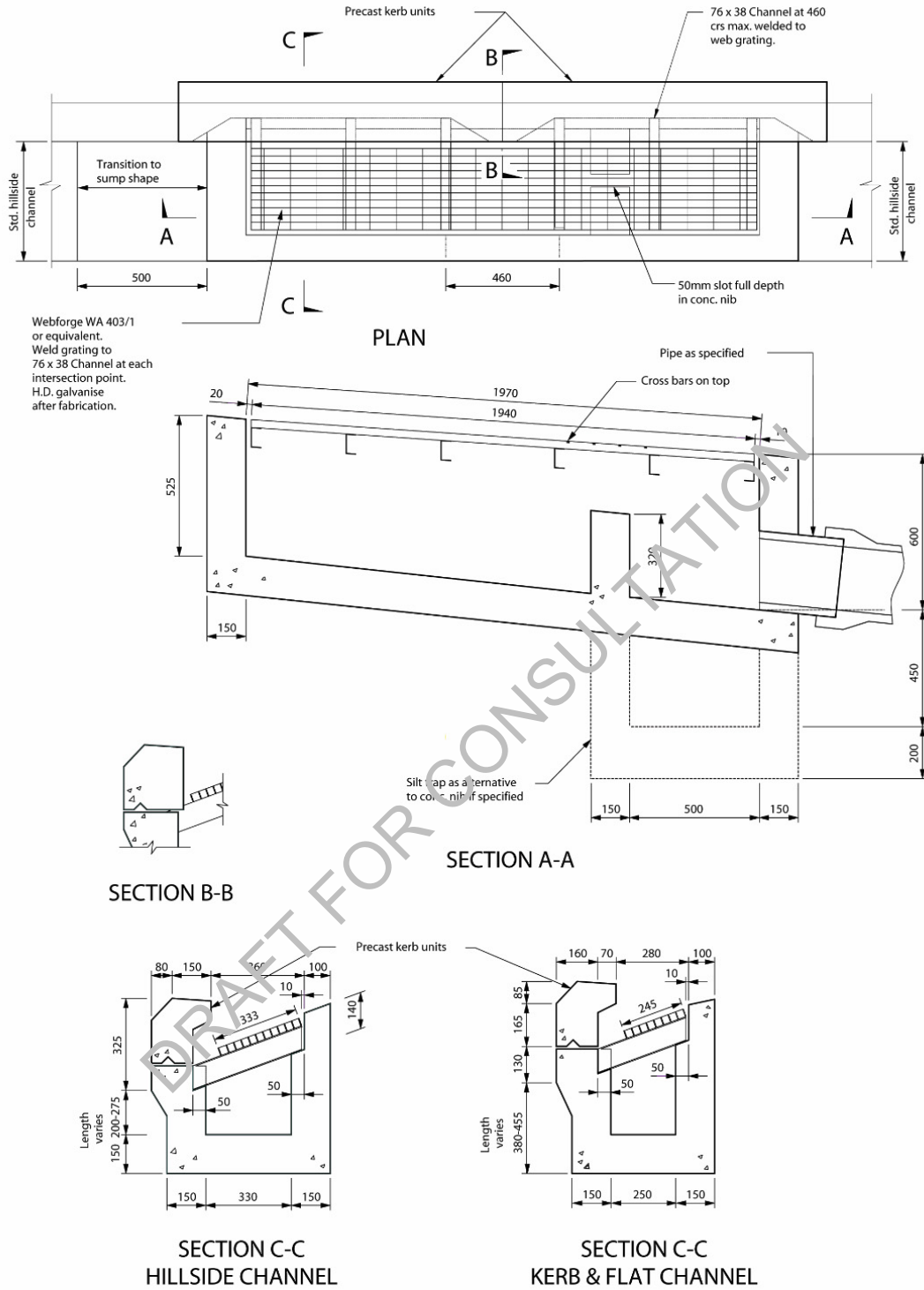
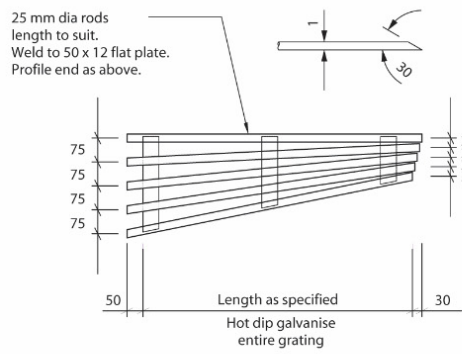
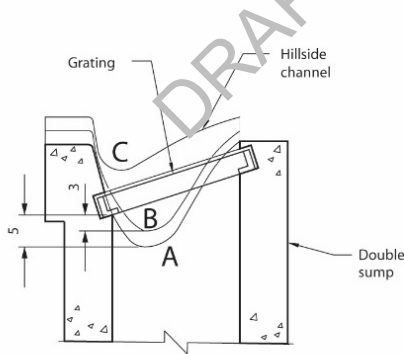
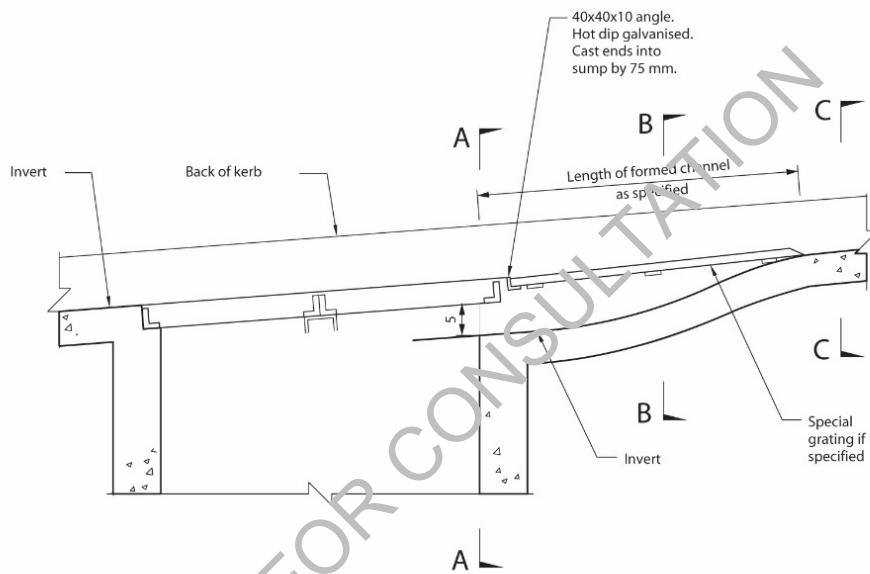
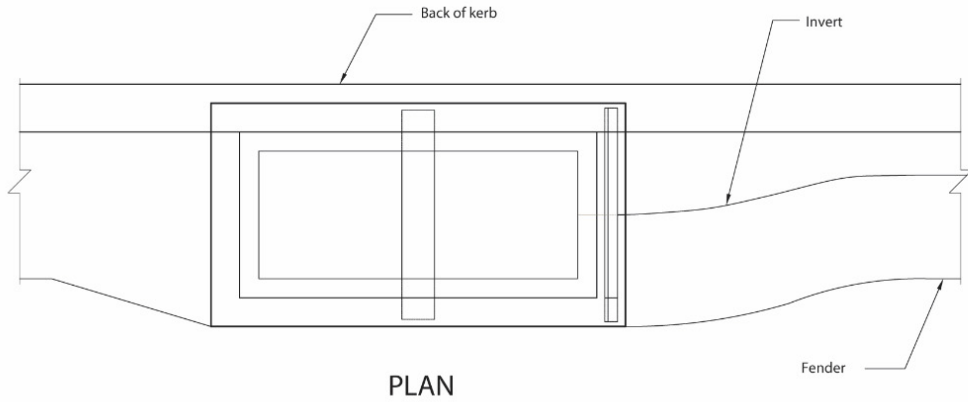

Figure 3.11 - Add-on to back-entry sump for hillside situations



ALL DIMENSIONS ARE IN MILLIMETRES

Figure 3.12 - An alternative sump for hillside situations



**NOTES –**

1. Further cross-bars on grate may be required for cycle safety.
2. All dimensions are in millimetres.

**Figure 3.13 - Special entry to double sump in hillside channel**

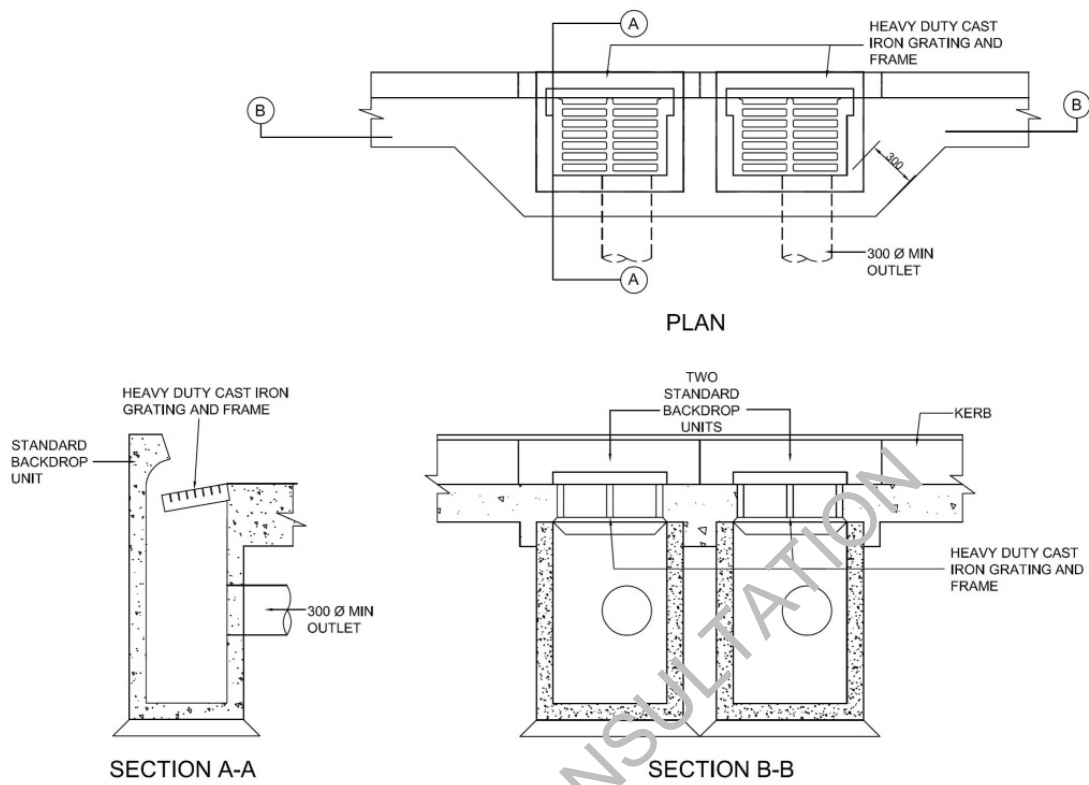

ALL DIMENSIONS ARE IN MILLIMETRES

**Figure 3.14 - Double back-entry sump for road low points**

**3.3.19.7.2 Sump design**

Sumps should be designed to intercept and convey stormwater run-off flow from design storm of the AEP set out by the TA, or otherwise stated in section 4 of this Standard, while allowing a reasonable frequency and degree of traffic interference. Depending on the road classification, as specified by the TAs, portions of the road may be inundated during major storm events. See 4.3.4.2 for allowable floodwater depths.

The following general guidelines should be used in the design of sumps:

- (a) General safety requirements
  - (i) Provide for the safety of the public from being swept into the stormwater system; the maximum allowable opening shall not exceed 100 mm in width
  - (ii) Openings are sufficiently small to prevent entry of debris that would clog the stormwater system
  - (iii) Openings be sized and oriented to provide for safety of pedestrians and cyclists. Cycle-friendly sump grates shall be used where required by the TAs. These grates may be built either with bars transverse to the side channel direction or closely spaced bars in a wavy pattern in a longitudinal direction;
- (b) Sump inlet capacities
 

Inlet capacities of any sump used should be determined using manufacturers' and suppliers' data which should be based on either rational analysis or first principle calculations, otherwise sump inlet capacities should be calculated using approved design methods where applicable. When no proper data is available, the capacity of the single 600 dia back entry sump with standard grating should be limited to 25 L/s.

The calculated sump inlet capacities should be reduced to account for partial blockage of the inlet with debris as follows:

On-grade grated back entry sump	10% reduction
On-grade grated sump	50% reduction
On-sag grated sump	50% reduction
On-sag grated back entry sump	Include back entry capacity only

- (c) The use of silt traps is encouraged in all sumps to provide partial treatment to stormwater at the source, but in all cases, trapped sumps should be used where discharge to a soakage device is permitted.

**3.3.19.7.3 Sump grating**

Sump grating areas shall be sized generously to allow for partial blockage to ensure that side-channel water does not bypass sumps when velocities are high.

Cycle-friendly sump grates shall be used where cyclists can be expected or when required by the TA. These gratings may be built either with bars transverse to the side-channel direction or closely spaced bars in a wavy pattern in a longitudinal direction.

**3.3.19.7.4 Sump leads**

Leads should be designed to be of sufficient size to convey all the design capacity of the sump to the system. *The minimum size of a sump lead shall be 300mm diameter.* For double sumps and other high capacity sumps the minimum size of lead required is 300 mm diameter.

**3.3.19.7.5 Secondary flow provisions**

At all points where sump blockage may occur, or where design capacity may be exceeded, which could lead to overflow into private property, the provision of designed secondary flow paths protected by public ownership or easement shall be made (see 4.3.4.2). *Secondary flow paths shall be shown on engineering plans submitted for approval.*

## 3.4 Construction

### 3.4.1 Introduction

These requirements apply to flexible pavements. For rigid pavements, such as concrete pavements refer to Austroads guides, and the *Guide to residential streets and paths* as listed in Referenced Documents.

Road construction shall be carried out to the alignments and standards detailed in the approved drawings and with the specified materials so as to provide the intended design life.

The road construction includes all associated construction required to complete adjacent footpaths, berms, and road reserve areas.

### 3.4.2 Materials for flexible pavements

#### 3.4.2.1 Transition layer

A transition layer may be required for traffic loading in excess of  $1 \times 10^5$  ESA where the subgrade is soft, to prevent ingress of the soft soils into the pavement layers. The transition layer may be filter metal complying with appropriate NZTA specifications or an approved geotextile filter fabric. The transition layer shall be compatible with the grading of adjacent layers and be regarded as part of the total depth of the sub-base layer.

#### 3.4.2.2 Sub-base

The sub-base layer immediately beneath the basecourse shall have a permeability of at least  $10^{-4}$  m/s for a depth of at least 150 mm.

The material used as sub-base shall be hard rock material with the largest aggregate size not larger than 60% of the depth of the layer or 65 mm. The material shall be sufficiently free draining so as not to be susceptible to undue weakening at highest in-service moisture content.

*The sub-base material shall be free from all non mineral matter and shall have a CBR of at least 40 and a minimum crushing resistance of 65kN except for the provision of shell rock as used in the Patea/Waverley area.*

*Alternative products may be used with the approval of the TA. If non-mineral matter is proposed for sub-base it shall be free of biodegradable material.*

#### 3.4.2.3 Basecourse

The thickness of the basecourse layer when used with other metal aggregate layers shall not be less than 100 mm.

Acceptable basecourse specifications are:

- (a) NZTA approved regional basecourse  
This is a slightly lower quality material than NZTA specified M/4. It may be used for roads of connector/collector class. *The crushing resistance of TNZ M/4 is relaxed to 85kN; or*
- (b) Local basecourse acceptable to the TA  
This may be used for local roads in live and play areas and footpaths, kerb crossings, and shared accessways.

### 3.4.3 Road surfacing

#### 3.4.3.1 Acceptable surfacing materials

All movement lanes shall be provided with a permanent, hard wearing surfacing layer, which shall be either impermeable or formed over an impermeable base. The surfacing shall be capable of carrying all stresses expected during its lifetime.



Acceptable surfacing options may include:

- (a) Hot laid asphaltic concrete of minimum compacted thickness 30 mm, laid over a waterproofing sealcoat;
- (b) Other asphaltic concrete mixes such as friction course or macadam wearing mix laid over a waterproofing coat;
- (c) Chip seals of various types, providing the equivalent of two bound chip coatings;
- (d) *Running course, a free flowing stone aggregate with a maximum material size of 19.0mm, is an acceptable road surfacing option for gravel/unsealed roads and rural right of ways carrying out farming activities;*
- (e) Concrete block pavers; and
- (f) Stone block surfacing where designed for aesthetic effects.

Options (d), (e) and (f) are subject to TA approval.

To resist scuffing and local load effects, minimum surfacing standards as given in Table 3.3 shall apply to the named facilities.

Use of concrete or stone block paving in public traffic areas shall require the specific approval of the TA.

**Table 3.3 - Surfacing standards**

Facility	Minimum surfacing
Residential turning head	Segmental concrete pavers, concrete, 30 mm asphaltic concrete.
<i>Off street public carparks ( including recessed parking)</i>	Segmental concrete pavers, concrete, 30 mm asphaltic concrete
Commercial and industrial turning head	Segmental concrete pavers, concrete, 50 mm asphaltic concrete
Traffic islands and bus stops	Segmental concrete pavers, concrete, 50 mm asphaltic concrete
<i>All urban local roads in the New Plymouth District</i>	<i>30 mm asphaltic concrete or of a thickness that is fit for purpose subject to TA approval</i>

**3.4.3.2 Road surface tolerances and texture**

The finished surface of new roads shall have a NAASRA roughness satisfying the TA's standards at the time of construction. No abrupt or abnormal deviations shall occur and no areas shall pond water. The surface shall be of uniform texture expected by best trade practice and satisfy density standards applicable to the surfacing being used. The skid resistance and surface texture of roads where design speeds exceed 70 km/h, shall comply with NZTA specification T/10 and its accompanying notes.

Where hard surfacing is required for areas that are not movement lanes, alternative materials and porous pavements that achieve the durability, maintenance, and amenity requirements are acceptable with the approval of the TA.

**C3.4.3.2**

*In the cases of narrow traffic islands and bus stops, where loading is concentrated, the use of stabilised base course is also desirable.*

### 3.4.4 Road surfacing materials

All materials used in road surfacing shall comply with the appropriate NZTA specifications.

The following surfacing options will be acceptable for roads covered by the Standard.

#### 3.4.4.1 First and second coat chip seals

For first coat seals the chip size shall generally be grade 3 on all roads.

For second coat seals the chip size shall generally be grade 4. Cycle and parking lanes shall be grade 6.

#### 3.4.4.2 Double wet lock coat

First and second seals may be constructed in one operation with asphaltic cutback to NZTA M/1 and P/3 specifications.

The binder application rate for the seals shall be designed to suit the conditions and chip size.

Acceptable and compatible chip sizes are:

*Local and other roads*

First coat: grade 3, second coat: grade 5 or 6.

#### 3.4.4.3 Hot laid asphaltic concrete surfacing

Hot laid asphaltic concrete surfacing shall comply with NZTA specification M/10 or equivalent approved by the TA. The mix used shall be appropriate to the end use and thickness being placed.

A waterproofing seal coat, using asphaltic binder or emulsion, and grade 5 chip, with the requirement that the seal coat comprises a minimum of 1.0 L/m<sup>2</sup> of residual penetration grade bitumen, shall be laid prior to surfacing with asphaltic concrete of 50 mm or lesser thickness. No cut back shall be used in such coats as it can cause flushing of the asphalt overlay.

When using NZTA specification M/10 compliant mixes on roads of connector/collector class, NZTA guidelines on skid resistance and surface texture shall be incorporated in the mix design.

#### 3.4.4.4 Other asphaltic mixes

For special uses other asphalt-based hot mixes may be used such as open grade porous asphalt or macadam wearing mix. When used they shall be placed over a waterproof under layer and shall be designed according to current specifications and guides. In no case shall the laid thickness be less than 30 mm.

#### 3.4.4.5 Concrete

All concrete for roads shall come from a special grade plant as defined in NZS 3109. Concrete of not less than 30 MPa 28-day strength shall be used for any road or crossing slabs.

Concrete for kerbs and channel, *and vehicle crossings* shall be of not less than 20 MPa, 28-day strength.

#### 3.4.4.6 Concrete pavers

Design and material standards shall comply with NZS 3116. Paver thickness shall be as defined in NZS 3116 for the appropriate traffic loading classification.

When used in roads the basecourse underlayer shall be given a waterproofing seal coat before the sand and pavers are laid, except where part of a porous pavement is approved by the TA.

When used for bus stops or at raised crossings the basecourse shall be cement stabilised under the raised zone and for at least 3 m on either side of the raised zone.

Pavers shall be laid to 5 mm above the lips of channels and other draining features.

### 3.4.5 Subgrade checking

Where the extent of cut or fill for the project is too great to make subgrade CBR testing feasible at the design stage, it should be done on completion of earthworks when subgrade levels have been exposed. Even in cases where the subgrade has been tested as part of the design its condition shall be reviewed on exposure during construction and pavement thicknesses adjusted accordingly.

The results of such testing or review along with any consequent adjustments to pavement layer thicknesses shall be advised to the TA before placing of pavement layers commences.

Any identified wet spots in the subgrade shall be drained to the under-channel drainage system. Where the wet area is below the level of the under-channel drain, it shall be drained using approved filter drainpipes connected to the nearest stormwater system.

Between the date the subgrade is completed and the application of the first metal-course aggregate, the subgrade shall be maintained true to grade and cross section. Should potholes, soft spots or ravelling develop in the subgrade, the area so affected shall be scarified and clean material added and recompacted.

### 3.4.6 Spreading and compaction of metal course aggregates

The metal course aggregates shall be placed on the prepared subgrade in layers. The aggregate layers shall be of adequate thickness and stiffness to ensure that with adequate compaction the minimum required deflections are achieved.

### 3.4.7 Sub-base

Sub-base material shall be placed in layers thin enough to ensure requisite compaction and CBR standards are achieved. Sub-base shall be compacted in accordance with NZTA B/2 specification to achieve a mean of 95% of maximum dry density (MDD) and a minimum of 92% of MDD.

The layers shall be so placed that when compacted they will be true to the grades and levels required. The laying procedure shall be arranged to minimise segregation. Grader use shall be restricted to essential shaping and final trimming, with minimum working of the final surface.

The sub-base layer may be used by construction traffic, but such traffic shall be managed to ensure no detrimental effects to the final road construction.

### 3.4.8 Basecourse

Basecourse shall be placed in layers not exceeding 150 mm. It shall be placed and compacted to NZTA B/2 specification density requirements to achieve a mean of 98% MDD and a minimum of 95% MDD.

Where approved by the TA, cement stabilised basecourses should be placed and compacted in accordance with the NZTA B/5 specification.

To assist compaction, water may be added as a fine mist spray to achieve optimum moisture content. Particular care shall be taken to avoid excess water reaching the formation or sub-base course.

Fine aggregate may be hand spread in a comparatively dry state over any open textured portion of the final compacted aggregate surface. The fine aggregate shall be vibrated or rolled into the interstices of the basecourse. The use of such surface choking material shall be kept to a minimum. Special attention shall be paid to the consolidation of the edges of the basecourse.

The construction of the basecourse shall be carried out in a manner that will ensure the production of a stone mosaic surface after sweeping.

### 3.4.9 Maintenance of basecourse

The finished aggregate surface shall be maintained at all times true to grade and cross section by placement of a 'running course', watering as required, trimming, planning, rolling, and taking appropriate measures to ensure the even distribution of traffic.

Every precaution shall be taken to ensure that the surface of the basecourse does not pothole, ravel, rut or become uneven, but should any of these conditions become apparent, the surface shall be patched with suitable aggregate and completely scarified and recompacted. The basecourse shall be maintained to the specified standards until covered with an impermeable surfacing layer.

### 3.4.10 Basecourse preparation for surfacing

Any loose or caked material shall be removed from the surface without disturbing the compacted base, and the material so removed shall be disposed of. The surface shall then be swept clean of any dust, dirt, animal deposits, or other deleterious matter. The surface of the road at the time of surfacing shall be clean, dry and uniform, tightly compacted, and shall present a stone mosaic appearance. Immediately prior to any form of surfacing a strip 600 mm wide contiguous to each channel or seal edge shall be sprayed with an approved ground sterilising weed killer at the manufacturer's recommended rate of application.

For second coat sealing, repairs shall be carried out prior to sealing. Areas to be patched shall be cleaned and loose material removed before application of an emulsion tack coat and asphaltic patching material. The repairs shall provide a finished surface flush with the levels and grades of the surrounding pavement, and shall not hold water.

Prior to commencement of sealing the surface preparation shall be inspected by the TA.

### 3.4.11 Deflection testing prior to surfacing

Where required by the TA prior to placing the surfacing layer (except for cast in situ concrete roads) deflections shall be tested by the Benkelman beam method (see Table 3.4). At least 95% of all tests shall comply with the standards appropriate to the road type. Where the TA does not have its own deflection standards Table 3.4 shall be considered as a minimum standard. In addition no test shall give deflections greater than 25% above the specified maximum.

**Table 3.4 - Benkelman beam standards**

<i>Residential and recreational areas</i>	<b>Deflections</b>		<i>All other areas</i>	<b>Deflections</b>	
	<b>Average</b>	<b>Maximum</b>		<b>Average</b>	<b>Maximum</b>
Lane	1.50 mm	1.80 mm	Lane	1.00 mm	1.20 mm
Local road	1.50 mm	1.80 mm	Local road	1.00 mm	1.20 mm
Connector/collector	1.25 mm	1.50 mm	Connector/collector	1.00 mm	1.20 mm

Readings shall be taken in the wheel path in both lanes and at a maximum interval of 10m.

### 3.4.12 Surfacing specification

Chipsealing construction standards shall comply with NZTA specifications P/3 and P/4.

Asphaltic concrete construction standards shall comply with NZTA specification P/9.

### 3.4.13 Bitumen application rate

Bitumen application rate for chipseals and tack coats shall be assessed based on current NZTA design methods and ambient weather conditions at the time of construction.

### 3.4.14 Footpaths and cycle paths

#### 3.4.14.1 Concrete

*Concrete footpaths and cycle paths shall be formed over not less than 100 mm of compacted metal.* Concrete footpaths and cycle paths shall be formed over in-situ volcanic ash or not less than 100 mm of compacted metal. The formation is to be thoroughly compacted by rolling before any concrete is placed. Porous areas shall be blinded with sand prior to placing concrete.

The foundation shall be evenly trimmed to a crossfall of 1 in 50. If the foundation is dry, it shall be moistened in advance of placing concrete.

The concrete paths shall be laid with construction joints at intervals of not greater than 3 m. If paths are constructed by continuous pour techniques, clean, true, well-oiled 5 mm thick steel strips at least 40 mm deep shall be inserted at 3 m intervals to facilitate controlled cracking. These strips shall be carefully removed after the concrete has set. Alternatively, the joints may be cut by means of a concrete-cutting saw. In this case the cutting shall be carried out not more than 48 hours after pouring and shall be to a depth of 40 mm. These joints may also be typically tooled into the concrete when the concrete is still plastic.

Minimum concrete thickness for paths is 100 mm. Concrete in both footpaths and kerb and channel shall be cured for at least 7 days during dry weather.

Concrete used in footpaths shall be of at least 20 MPa, 28-day strength. Concrete for crossings shall be 20 MPa, 28-day strength as detailed in 3.4.4.5.

Where required, vehicle and mobility crossings shall be constructed in accordance with the TA standard details. Tactile pads may be required at pedestrian kerb crossings.

*Ensure that the construction joint spacing for K&C and footpaths are multiples of each other so that joints can line up, preferably 3 m, 6 m and 12 m centres, where practical.*

#### 3.4.14.2 Asphaltic concrete

Asphaltic concrete footpaths and cycle paths shall be placed over not less than 100 mm of compacted basecourse after removal of all organic and soft subgrade. Asphaltic concrete shall be laid in a minimum layer thickness of 25 mm of mix M/10 material. Asphalt concrete paths shall not puddle water and shall be edged with either concrete or ground treated timber where abutting berms or other grassed areas.

#### 3.4.14.3 Concrete pavers

Concrete pavers for footpaths shall be placed over not less than 100 mm of compacted basecourse after removal of all organic and soft subgrade. Laying shall be in accordance with NZS 3116. Pavers shall be laid to 5 mm above tops of channels and other drainage features.

#### 3.4.14.4 Surface finish, tolerances

Surface finish and tolerances on footpaths shall comply with the appropriate design requirements.

### 3.4.15 Kerb and channel

*Kerb and channel shall be extruded. Cast in situ is only permitted with prior TA approval.*

For cast in situ kerb and channel, formwork shall be clean dressed timber or steel sections adequately oiled or otherwise treated to allow ease of striking without staining or damaging of the stripped concrete surface.

No formwork shall be stripped until at least 2 days have elapsed from time of pouring concrete.

For extruded kerb and channel, concrete used shall be of such consistency that after extrusion it will maintain the kerb shape without support. The extrusion machine shall be operated to produce a well compacted mass of concrete free from surface pitting.

Concrete used in kerbs and channels shall be of at least 20 MPa, 28-day strength. Finished tolerances and standards shall satisfy the design standards.

*All kerb and channel shall be constructed on top of a compacted layer of an acceptable material with a minimum thickness of 100mm and preferably have construction joints placed in all un-reinforced kerb and channel at 6.0m centres. Ensure that the construction joint spacing for K&C and footpaths are multiples of each other so that the joins can line up, preferably 3 m, 6 m and 12 m centres, where practical.*

### **3.4.16 Berms and landscaping**

Berms shall be formed after all other construction has been completed. Grassed and planted areas shall have a 100 mm thick layer of topsoil free of weeds, stones, and other foreign matter and shall finish 15 mm above adjacent footpath level to allow for settlement.

After topsoiling, the berm shall be either sown or planted, or both, and maintained free of weeds for the contract maintenance period. The seed mix shall be approved by the TA.

When sown, rather than planted, grass coverage of not less than 90% shall be achieved within 1 month of sowing and before completion documentation will be accepted for processing by the TA.

For additional requirements for swales see 3.3.19.5.

Any landscaping in the road reserve shall be in accordance with section 7 of this Standard.

### **3.4.17 Surface finish and tolerances on kerbs, paths, and accessways**

#### **3.4.17.1 Kerbs and channel**

*All curves both horizontal and vertical shall be tangential to straights and the lines and levels of kerbs shall be such as to give the finished kerbs smooth lines free of kinks and angles. Construction joints shall be placed in all unreinforced kerb and channel at 10 m centres.*

Workmanship standards shall be such that, on straights, kerbing shall not deviate from a straight line by more than 6 mm in any length of 3 m. Similar standards shall apply to the gradient line. No visible ponding in new channels shall occur.

The exposed faces of the kerb and channel shall present smooth, uniform appearance free from honey-combing or other blemishes to at least U3 standard in NZS 3114.

#### **3.4.17.2 Paths and accessways**

Concrete paths and accessways shall be finished with a crossfall to shed water and an even non-skid brush surface to finish U5 in NZS 3114.

The surface of other paths/accessways shall be of uniform texture as would be expected from best trade standards for the surfacing used. Crossfalls of 2% shall be provided.

The surface of all paths/accessways shall not deviate by more than 6 mm from a 3 m straight edge at any point and no abrupt changes in line or level shall occur. No path/accessway shall pond water.

### **3.4.18 Progress inspections**

*The contractor shall give notice to the TA to allow the conduct of all inspections required to facilitate eventual acceptance of the project by the TA.*

**3.4.19 Installation of traffic services, road furniture, benchmarks**

Traffic lines and utility services shall be painted and marked after initial surfacing and sweeping has been completed. Road furniture and survey reference marks shall be installed, prior to final inspections being made by the TA.

**3.4.20 As-built and completion documentation**

On completion of construction, information and documents as required by the TA shall be provided by the developer's professional advisor. (See Schedule 1D for further information). The information provided shall provide sufficient detail to enable the TAs to complete the road assessment and maintenance management database input.

DRAFT FOR CONSULTATION

## **4 STORMWATER**

### **4.1 Scope**

This section sets out requirements for the design and construction of stormwater systems for land development and subdivision. The significant issues for stormwater management are the protection of people, property, infrastructure, and the receiving environment. Stormwater management requires the integration of land use, roading, and ecological factors. A catchment-based approach is required with consideration of changes in catchment hydrology, rainfall patterns, and sea level rise from climate change effects.

Opportunities exist with stormwater design to use or replicate the natural drainage system. Swales, natural or artificial waterways, ponds and wetlands, for example, may in certain circumstances be not only part of the stormwater system, but also a preferred solution especially if low impact on receiving waters downstream is critical. Low impact design is the preferred approach, particularly where there is a requirement to replicate the pre-development hydrological regime. Nevertheless piped stormwater systems will often be required either in support of low impact systems or as the primary system.

Stormwater systems serve a number of purposes including the management of storm surface water run-off, treatment of such run-off, and groundwater control. All aspects need to be considered in design and achieved with minimal adverse effects on the environment.

### **4.2 General**

#### **4.2.1 Objectives**

The primary objective of a stormwater system is to manage storm surface water run-off to minimise flood damage and adverse effects on the environment.

The stormwater system shall include provision for:

- (a) A level of service to the TA's customers in accordance with the authority's policies;
- (b) Minimised adverse environmental and community impact;
- (c) Protection from potential adverse effects to aquatic ecosystems;
- (d) Compliance with environmental requirements;
- (e) Adequate system capacity to service the fully developed catchment;
- (f) Long service life with consideration of maintenance and life-cycle cost;
- (g) Application of low impact design solutions.

#### **4.2.2 Legislation and guidance manuals**

Referenced legislation is listed in the Referenced Documents section of this Standard.

A selection of guidance manuals which may provide a useful resource or basis for stormwater design and management is set out in Referenced Documents and Related Documents. They are non-statutory in themselves but may be required to be complied with under regional or district plan rules.

#### **4.2.3 Territorial authorities' requirements**

The requirements of relevant regional and district plans on stormwater shall be met. Regional plan requirements will generally be limited to effects of stormwater on the natural environment. The TA exercises control over infrastructure associated with land development and subdivision.

Authorisation will be required from the regional council for the discharge of stormwater unless the discharge is to an existing and consented stormwater system and meets any conditions which apply to the existing system. Other activities often associated with stormwater infrastructure which need to



be authorised by the regional council include: the diversion of natural water during construction, the permanent diversion of natural water as a consequence of the development, activities in the bed or on the banks of a natural waterway, and damming waterways.

The discharge of clean stormwater and other activities where effects are considered minor may be authorised as a permitted activity subject to certain conditions in the regional plan. Authorisation may also be by way of a comprehensive consent held by the TA for a large area or entire catchment.

In other circumstances site specific discharge permits and water permits shall be obtained. Advice should be sought from the TAs at the earliest stage of planning for stormwater infrastructure and receiving waters.

Discharge and temporary water permits required during construction shall be applied for by the developer and exercised in the name of the developer.

#### C4.2.3

*The division of responsibilities between TAs and regional councils is set out in the Resource Management Act.*

### 4.2.4 Catchment management planning

Stormwater management planning should be carried out on a sub-catchment or catchment-wide basis. Where the proposed development is in an area covered by a territorial authority comprehensive catchment management plan, designers will be required to comply with the design philosophy in the plan.

If there is no catchment management plan for the area of the proposed development, the stormwater planning requirements should be discussed with the TAs at an early stage.

The implications of future development on adjoining land should be on the basis of replicating the pre-development hydrological regime whereby the maximum rate of discharge and peak flood levels post-development are no greater than pre-development.

Any catchment management planning issues should be discussed with TAs at an early stage.

*See Section 4.6 for details required in a Catchment Management Planning Report.*

### 4.2.5 Effects of land use on receiving waters

Impervious surfaces and piped stormwater systems associated with development have an effect on catchment hydrology. Faster run-off of storm flows, reduction in base flows, and accelerated channel erosion and depositions alter the hydrology and adversely affect the quality of receiving waters. Development should aim to minimise the increase in the frequency at which pre-development discharges are exceeded across a range of design rainfall events as this has implications for the biodiversity of the aquatic biological community.

The effects of rural development on receiving waters are generally less significant. The modification to stream hydrology is generally minor. However, any reduction in riparian vegetation increases sediment loads and nutrient concentrations are likely to reduce aquatic biodiversity.

### 4.2.6 System components

The stormwater system conveys storm surface run-off and shallow groundwater from the point of interception to soakage areas, attenuation areas, or the point of discharge to receiving waters. Components of the primary system may include roadside channels, swales and sumps, stormwater pipelines, subsoil drains, outlet structures, soakage areas, wetlands, ponds, and water quantity and quality control structures. Secondary surface flow paths to convey primary system overflows will also be required.

These different system components are set out on standard construction drawings contained in Appendix B. The drawings are copyright waived and may be adapted by subdivision developers for incorporation into specific designs.

#### **4.2.7 Catchments and off-site effects**

All stormwater systems shall provide for the management of stormwater run-off from within the land being developed together with any run-off from upstream catchments. In designing downstream facilities the upstream catchment shall be considered to be fully developed to the extent defined in the operative district plan or structure plan unless the TA advises that the upstream catchment will be required to be controlled for off-site effects at the time of its development.

For all land development infrastructure (including projects involving changes in land use or coverage) the design of the stormwater system shall include the evaluation of stormwater run-off changes on upstream and downstream properties. This evaluation will be required at the resource consent stage and may be linked to a requirement to replicate the pre-development hydrological regime.

Upstream flood levels shall not be increased by any downstream development unless any increase can be shown to have not more than a minor impact on the upstream properties.

Downstream impacts could include (but are not limited to) changes in flow peaks and patterns, flood water levels, contamination levels and erosion or silting effects, and effects on the existing stormwater system. Where such impacts are more than minor, mitigation measures such as peak flow attenuation, velocity control, and treatment devices will be required.

Fish passage shall be maintained. This is likely to be a requirement of any authorisation from the regional council.

#### **4.2.8 Water quality**

Stormwater treatment devices may be required to avoid adverse water quality effects on receiving waters. The type of potential contaminants should be identified and then treatment devices designed to address the particular issues. The need for treatment devices should be considered for every discharge even when it is not a direct discharge to a receiving water, for instance where the discharge is to an existing network. In this instance specific approval from the TA will be required.

*The use of appropriate on site treatment systems provides for options to treat stormwater runoff to minimise the impact on downstream receiving waters. Specifically the potential for point discharges and downstream erosion effects are to be considered and any appropriate measures designed for. The Taranaki Regional Fresh Water Plan may provide other requirements that must be adhered to for many natural waters.*

*Operations and Maintenance guidelines shall be provided for any water quantity and/or quality control structures and formed features such as ponds. The guidelines shall describe the design objectives of the structure, describe all major features, explain operations such as recommended means of sediment removal and disposal, identify key design criteria, and identify on going management requirements such as plant establishment, vegetation control and nuisance control and the manual shall be provided to the TA upon vesting of the stormwater assets.*

#### **4.2.9 Climate change**

Climate change is expected to increase the intensity and frequency of heavy rainfall events, even in areas where mean annual rainfall is predicted to decrease. In low-lying coastal areas higher sea levels will also affect rivers, streams, and stormwater outfalls. The performance of stormwater systems in these areas will need to take into account higher predicted downstream sea levels.

Rainfall design charts shall be adjusted to take into account the predicted increase in rainfall intensities from the effects of climate change.

**C4.2.9**

Refer to the following Ministry for the Environment publications for guidance on climate change:

*'Preparing for climate change – A guide for local government in New Zealand' for guidance on adjusting rainfall design charts at selected locations within each regional council area.*

*'Preparing for coastal change – A guide for local government in New Zealand' for guidance on coastal hazards and climate change.*

*'Tools for estimating the effects of climate change on flood flow – A guidance manual for local government in New Zealand' for incorporating climate change in flood flow estimation.*

*'Preparing for future flooding – A guide for local government in New Zealand' provides an overview of the expected impacts of climate change on flooding.*

Refer also to NIWA publication "Impacts of Climate Change on Urban Infrastructure and the Built Environment".

**4.3 Design****4.3.1 Design life**

All stormwater systems shall be designed and constructed for an asset life of at least 100 years. Some low impact design devices such as rain gardens and other soakage systems may require earlier renovation or replacement.

**4.3.2 Structure plan**

The TA may provide a structure plan setting out certain information to be used in design, such as flows, sizing, upstream controls, pipe layout, treatment, or mitigation requirements. Catchment management plans should detail the appropriate stormwater management options for the given structure plan area. Where a structure plan is not provided, the designer shall determine the information by investigation using any catchment management plan for the area, this Standard, and any requirements of the TA, as appropriate.

**4.3.3 Future development**

Where further subdivision, upstream of the one under consideration, is provided for in the district or regional plan, the TA may require stormwater infrastructure to be constructed to the upper limits of the subdivision.

Additionally, the TA may require further capacity to be provided in the TA stormwater system to cater for existing or future development upstream.

**4.3.4 System design****4.3.4.1 Primary and secondary systems**

Stormwater systems shall be considered as the total system protecting people, land, infrastructure, and the receiving environment.

A stormwater system consists of:

- (a) A primary system designed to accommodate a specified design rainfall event; and
- (b) A secondary system to ensure that the effects of stormwater run-off from events that exceed the capacity of the primary system are managed, including occasions when there are blockages in the primary system.

**4.3.4.2 Secondary systems**

Secondary systems shall consist of ponding areas and overland flow paths to manage excess run-off. Where possible, secondary systems shall be located on land that is, or is proposed to become public

land. If located on private land, the secondary system shall be protected by legal easements in favour of the TA or by other encumbrances prohibiting earthworks, fences, or other structures, as appropriate.

Secondary systems shall be designed so that erosion or land instability will not occur. Where necessary the design shall incorporate special measures to protect the land against such events.

*Ponding or secondary flow on local roads shall be limited to a velocity such that the carriageway is passable by an 85<sup>th</sup> percentile vehicle in a 5% AEP design storm avoiding water entering private property.*

The TA should be consulted to confirm design requirements.

#### C4.3.4.2

*The Austroads 'Guide to road design – Part 5: Drainage design' provides more information on major and minor stormwater design and acceptable volume and velocity for surface flow.*

#### 4.3.4.3 Building Over/Near Pipelines

For the purposes of this Standard any proposal to build over a Council stormwater drain will be considered as though the stormwater drain is a sewer and is subject to the requirements of the council's bylaws.

*The location of buildings or structures over or near an existing sewer is subject to the requirements of the relevant TA's bylaws.*

*No building shall be built over any buried public services whether on public or private land within the New Plymouth district.*

#### 4.3.5 Design criteria

When the design process includes the use of a hydrological or hydraulic model, all underlying assumptions (such as run-off coefficients, time of concentration, and catchment areas) shall be clearly stated so that a manual check of calculations is possible. A copy of the model may be required by the TA for either review or records or both.

The designer shall undertake the necessary design and prepare design drawings compatible with the TA's design and performance parameters. Designers shall ensure the following aspects have been considered and where appropriate included in the design:

- (a) The size of pipes, ponds, swales, wetlands, and other devices in the proposed stormwater management system;
- (b) How the roading stormwater design is integrated into the overall stormwater system;
- (c) The type and class of materials proposed to be used;
- (d) System layouts and alignments including:
  - (i) Route selection;
  - (ii) Topographical and environmental aspects (see 5.3.4.3);
  - (iii) Easements;
  - (iv) Clearances from underground services and structures (see 5.3.7.9 and 5.3.7.10);
  - (v) Provision for future extensions;
  - (vi) Location of secondary flowpaths;
- (e) Hydraulic adequacy (see 4.3.9.5); and
- (f) Property service connection locations and sizes (see 4.3.11).

The designer should liaise with the TA, prior to commencement of design, to ensure that sufficient prerequisite information is available to undertake the design.

For catchments less than 50 ha, surface water run-off using the Rational Method will generally be accepted. For larger catchments, or where significant storage elements (such as ponds) are incorporated, surface water run-off should be determined using an appropriate hydrological or hydraulic model.

The New Zealand Building Code (NZBC) clause E1/VM1 provides guidance in the design of pipes, culverts, and open channel hydraulics.

#### 4.3.5.1 Design storms

All new stormwater systems shall be designed to provide level of service and level of protection in the design storm as follows:

a) *Level of Service*

*Primary flow path (pipelines and open channels) shall be provided to convey Stormwater to an appropriate discharge using gravity flow. They shall have sufficient capacity to convey flows from the storm events according to land use set in Table 4.1*

b) *Level of Protection*

*Secondary flow paths shall be identified and controlled so that the requirements for freeboard to floor levels is achieved by a combination of flow in Primary and secondary flow paths for the storm events according to land use set as follows in Table 4.1.*

*Where it is not possible to achieve the level of protection by use of secondary flow paths, then the primary flow path shall be increased in capacity until the level of protection can be achieved.*

**Table 4.1 - Minimum AEP for design storms**

<b>Function</b>	<b>AEP (%)</b>	<b>Return Period (years)</b>
<b>LEVEL OF SERVICE</b>		
<i>Parks, Reserves, Sports Grounds</i>	20	5
<i>Residential Land (New Plymouth District)</i>	20	5
<i>Residential Land (South Taranaki and Stratford District)</i>	10	10
<i>Commercial Land</i>	10	10
<i>Industrial Areas</i>	10	10
<i>Public Buildings</i>	10	10
<i>Road Culverts</i>	10	10
<i>Bridges</i>	1	100
<b>LEVEL OF PROTECTION</b>		
<i>Parks, Reserves, Sports Grounds</i>	20	5
<i>Residential Land and Accessory Buildings (New Plymouth District)</i>	20	5
<i>Residential Land and Accessory Buildings (South Taranaki and Stratford District)</i>	10	10
<i>Residential Floors</i>	1	100
<i>Commercial Floors</i>	1	100
<i>Industrial Floors</i>	1	100
<i>Public Buildings</i>	1	100
<i>Road Culverts</i>	2	50
<i>Bridges</i>	1	100

**C4.3.5.1**

*NIWA's High Intensity Rainfall Design Systems (HIRDS) data is the rainfall design dataset to be used with the assumption of RCP 6.0 Scenario for the period 2081-2100.*

**4.3.5.2 Freeboard**

The minimum freeboard height additional to the computed top water flood level of the 1% AEP design storm should be as follows or as specified in the district or regional plan:

<b><u>Freeboard</u></b>	<b><u>Minimum height</u></b>
Habitable dwellings (including attached garages)	0.5 m
Commercial and industrial buildings	0.3 m
Non-habitable residential buildings and detached garages	0.2 m

The minimum freeboard shall be measured from the top water level to the building platform level or the underside of the floor joists or underside of the floor slab, whichever is applicable.

**4.3.5.3 Tidal areas**

In tidal areas, design criteria should be discussed with the TAs at an early stage. Storm surge, tsunami hazards, climate change, and sea level rise need to be taken into account in accordance with the proposed NES on sea level rise and assessed in line with the Ministry for the Environment guidance manual *Coastal hazards and climate change – A guidance manual for local government in New Zealand*.

**4.3.5.4 Hydraulic design of stormwater systems**

*The hydraulic design of stormwater pipes should be based on either the Colebrook-White formula or the Manning formula. The coefficients to be applied for pipe roughness shall be  $k = 1.5$  for Colebrook-White or  $n = 0.013$  for Manning's. These coefficients shall be used irrespective of the pipe material. Open channel system capacity shall be determined from the Colebrook-White or Manning coefficients as shown in Table 4.2. The Colebrook-White and Manning formulae can be found in *Metrication: Hydraulic data and formulae (Lamont)*. Manufacturers' specifications should also be referred to.*

**Table 4.2 - Manning's "n"**

<b>Description</b>	<b>Condition of Channel Surface</b>	<b>"n" value</b>
Concrete		0.014
Asphalt Concrete		0.016
Chipseal		0.025
Timber	Well-planned, fitted continuous	0.01
	Well-fitted but not planned	0.012
	Old, Badly fitted, not planned	0.015
Stoneware	Glazed	0.01
Masonry, brick work	Neatly plastered	0.01
	Sand / Cement plaster	0.012
	Well laid brick and dressed ashlar	0.013
	Rough brick work, well dressed stone	0.013
	Rubble masonry	0.017
Metal	Enamelled	0.01
	Riveted, slight tuberculation	0.015
Gravel	Fine	0.017
	Coarse but well rammed	0.02
Earth	Good uniformity and condition	0.017
	Ordinary condition	0.025
	Poor, weeds, shingle banks, pools	0.03 - 0.035
	Bad, turbulent flow, obstructions, tree in channel, etc	0.04 - 0.15
UPVC	Typical undulations	0.009 - 0.01
Corrugated plastics	Clean	0.014 - .018
Stony bottom	Smooth Stone	0.035
	Rough Stone	0.04
Flood Plain	Pasture	0.032
	Cultivated	0.035
	Brush	0.06
	Trees	0.1
Weeds	Grass & weeds little or no Bush	0.03 - 0.035
	Dense weeds, water just over weeds	0.035 - 0.05
	Some weeds, light brush on banks	0.035 - 0.05
	Some weeds, heavy brush on banks	0.05 - 0.07
	Some weeds, dense willow on banks	0.060 - 0.08
<i>For trees &amp; branches submerged in Flood add another 0.01 to 0.02</i>		
<i>For irregular channels, pools, meanders, etc, add a further 0.01 to .02</i>		

#### 4.3.5.5 Energy loss through structures

Energy loss is expressed as velocity head:

$$\text{Energy loss } H_e = kV^2/2g$$

where k is the entrance loss coefficient and V is velocity.

The entrance loss coefficient table and energy loss coefficient graph in NZBC clause E1/VM1 provide k values for flow through inlets and access chambers respectively.

**4.3.5.6 Determination of water surface profiles**

Stormwater systems shall be designed by calculating or computer modelling backwater profiles from an appropriate outfall water level. On steep gradients both inlet control and hydraulic grade line analysis shall be used and the more severe relevant condition adopted for design purposes. For pipe networks at MHs and other nodes, water levels computed at design flow shall not exceed finished ground level while allowing existing and future connections to function satisfactorily.

In principle, each step in the determination of a water surface profile involves calculating a water level upstream ( $h_2$ ) for a given value of discharge and a given start water level downstream ( $h_1$ ).

This can be represented as:

$$h_2 + V_2^2 / 2g = h_1 + V_1^2 / 2g + H_f + H_e$$

where V is velocity,

$H_f$  is head loss due to boundary resistance within the reach (for pipes, unit head loss is read from Manning's flow charts, for example),

$H_e$  is head loss within the reach due to changes in cross section and alignment (see Table 4.3 for loss coefficients).

**Table 4.3 – Loss coefficients for bends**

Bends	k
MH properly benched with radius of bend 1.5 x pipe diameter	0.5 to 1.0
Bend angle	
90°	0.90
45°	0.60
22.5°	0.25

**4.3.6 Stormwater pumping**

Stormwater pumping should be avoided wherever possible. However, in certain circumstances for low lying areas, and where gravity drainage is difficult to achieve, stormwater pumping may be required to achieve the appropriate levels of service and protection.

The consequences and risk of pump malfunction and power outages should be considered carefully.

*Acceptance of stormwater pumping is at the sole discretion of the TA.*

**C4.3.6**

*Sea level rise scenarios may need to be assessed in line with the proposed NES on sea level rise. Such assessments are likely to indicate the need to design for or at least plan for stormwater pumping in the future to ensure levels of service are maintained throughout asset life.*

**4.3.7 Low impact design**

Low impact design aims to use natural processes such as vegetation and soil media to provide stormwater management solutions as well as adding value to urban environments. The main principles of low impact design are reducing stormwater generation by reducing impervious areas, minimising site disturbance, and avoiding discharge of contaminants. Stormwater should be managed as close to the point of origin as possible to minimise collection and conveyance. Benefits include limiting discharges of silt, suspended solids, and other pollutants into receiving waters, and protecting and enhancing natural waterways.



Effective implementation of LID principles typically requires more planning and design input than piped stormwater systems. Aspects in the design process requiring specific consideration include provision of secondary flow paths, land requirements, and provision for effective operation and maintenance.

*LID is synonymous with Water Sensitive Design in the New Plymouth District.*

**C4.3.7**

*Useful guidance on low impact design practices can be found in the following Auckland Regional Council (ARC) publications: 'Low impact design manual for the Auckland region, Technical Publication 124'; 'Application of low impact design to brownfield sites, Technical Report 2008-20'; and 'Integration of low impact design, urban design and urban form principles, Technical Report 2009-83'.*

**4.3.7.1 Low impact design stormwater system**

Low impact design is a type of stormwater system that aims to minimise environmental impacts by:

- (a) Reducing peak flow discharges by flow attenuation;
- (b) Eliminating or reducing discharges by infiltration or soakage;
- (c) Improving water quality by filtration;
- (d) Installing detention devices for beneficial reuse.

**4.3.7.2 Low impact design process**

Key design considerations include:

- (a) Design objective. The need to be clear about what is being designed for is important to informing decisions on the type of device and maintenance approach that is appropriate in a given context. Low impact devices offer many opportunities to deliver multiple outcomes in addition to their stormwater functionality;
- (b) Device selection. The proper design and position of a product or device within the stormwater treatment train is important. It is critical to select a device or product that is fit for purpose, robust, and effective for delivering the design objective over its design life. Problems with the operation and maintenance of a device can occur when it is inappropriate for a given location or is undersized for its purpose. The respective position of the various components in the treatment train is an important consideration in ensuring the sustained effectiveness of the system;
- (c) Integrated approach. Ensure that those who will become responsible for the ongoing operation and maintenance of low impact devices are involved in the design process. This is critical to informing the development of a practical design that will enable ease of maintenance and develop ownership for ensuring the device performs as it was intended;
- (d) Design for maintenance. Maintenance of devices shall be considered early in the design process. This will assist in the identification of features that will facilitate the ease and efficiency of ongoing operation and maintenance of devices. Elements to consider in the design for the maintenance and operation of the systems include:
  - (i) Access;
  - (ii) Vegetation;
  - (iii) Mulch;
  - (iv) Sediment;
  - (v) Mechanical components;
  - (vi) Vandalism and safety.

**4.3.7.3 Low impact design devices**

The types of low impact design devices that could be considered for use include:

- (a) Detention ponds;
- (b) Wetlands;
- (c) Vegetated swales;
- (d) Rain gardens;
- (e) Rainwater tanks;
- (f) Soakage pits and soak holes;
- (g) Filter strips;
- (h) Infiltration trenches/basins;
- (i) Permeable paving;
- (j) Green roofs;
- (k) Tree pits.

**4.3.7.4 Detention ponds**

Stormwater ponds are an accepted method of improving stormwater quality and reducing peak downstream flow rates to replicate the pre-development hydrological regime.

Detention ponds can be of the 'dry' or 'wet' type and can be 'on-line' or 'off-line'. The type of pond required should be discussed with the TA at an early stage.

Specific matters to be considered in pond design include:

- (a) Side slope stability;
- (b) Shallow ledges or batters for safety;
- (c) Ease of access and maintenance including mowing and silt clean out;
- (d) Shape and contour for amenity and habitat value;
- (e) Effectiveness of inlet and outlet structures;
- (f) Overflow design and scour protection;
- (g) Fish passage;
- (h) Pest control (for example mosquitoes and blue-green algae);
- (i) Species to be planted;
- (j) Potential effect on downstream aquatic ecology and habitat;
- (k) Maintenance requirements.

If the TA is to be responsible for pond maintenance it shall be located on land owned by, or to be vested in, the TA or protected by an appropriate easement.

**4.3.7.5 Wetlands**

Constructed wetlands can be designed to provide flood protection, flow attenuation, water quality improvement, recreational and landscape amenity, and provision for wildlife habitat.

Specific matters to be considered in wetland design include:

- (a) Catchment area greater than 1 ha;
- (b) Size calculated to achieve water quality volume;
- (c) Forebay to capture coarse sediments;

- (d) Depth not to exceed 1 m;
- (e) Sufficient hydraulic capacity for flood flows;
- (f) Sufficient detention time for sediment retention;
- (g) Species to be planted.

If the TA is to be responsible for wetlands maintenance it shall be located on land owned by, or to be vested in, the TA or protected by an appropriate easement.

#### 4.3.7.6 Vegetated swales

Vegetated swales are stormwater channels that are often located alongside roads or in reserves. While their primary function is conveyance, filtration through the vegetation provides some water quality treatment.

Specific matters to be considered in swale design include:

- (a) Catchment area not greater than 4 ha;
- (b) Longitudinal slope 1% – 5%;
- (c) Slopes flatter than 1% may require underdrains;
- (d) Capacity for a 10% AEP event;
- (e) Velocity not greater than 1.5 m/s in a 10% AEP event unless erosion protection is provided;
- (f) *Refer to the relevant TA for a list of appropriate species.*

An option for swales with very flat longitudinal slopes and high water tables is a wetland swale.

Typical details that may be used in swale design are shown in *Figure 3.6*. *Further information to be discussed with the relevant TA can be found in Christchurch City Council's Rain Garden Design, Construction and Maintenance Manual, May 2016.*

#### 4.3.7.7 Rain gardens

Rain gardens are engineered bio-retention systems designed to use the natural ability of flora and soils to reduce stormwater volumes, peak flows, and contamination loads. Rain gardens also provide value through attractive design and planting. *Further information to be discussed with the relevant TA can be found in Christchurch City Council's Rain Garden Design, Construction and Maintenance Manual, May 2016.* Specific matters to be considered in rain garden design include:

- (a) System designed to manage a 10% AEP event without significant scour or erosion;
- (b) Overland flow paths to accommodate flows in excess of the design storm;
- (c) Entry and overflow positions to restrict short circuiting;
- (d) Geotextile on side walls;
- (e) An underdrain with a minimum of 50 mm gravel cover;
- (f) Pavement design in vicinity of device;
- (g) Soil composition;
- (h) A ponding area;
- (i) *Refer to the relevant TA for a list of appropriate species.*
- (j) Access for maintenance.

#### 4.3.7.8 Rainwater tanks

Rainwater tanks can be designed to harvest water for non-potable uses such as toilet flushing and watering the garden. This can significantly reduce the demand on the potable water supply from the TA. Where required by the TA rainwater tanks can be configured to provide peak flow attenuation, to reduce stream channel erosion and the load on the stormwater system, with or without reuse.

Specific matters to be considered in rainwater tank design include:

- (a) Capacity: Typically 2,000 L – 5,000 L for domestic reuse and 6,000 L – 9,000 L for dual reuse and attenuation;
- (b) Primary screening to keep out leaves and other coarse debris;
- (c) First-flush diverters to collect first 0.4 mm for slow release to ground through a small chamber;
- (d) Backflow prevention;
- (e) Low level mains top-up valve;
- (f) Overflow outlet;
- (g) Gravity or pumped;
- (h) Tight-fitting cover;
- (i) Cool location;
- (j) Aesthetics and convenience.

#### **4.3.7.9 Soakage devices**

Soakage devices such as soak pits and soak holes, filter strips, infiltration trenches/basins, permeable paving, green roofs, and tree pits can also be considered for managing stormwater from roofs, parking areas, and roads.

Specific matters to be considered in soakage system design include:

- (a) Capacity adequate for a 10% AEP event;
- (b) Rate of soakage determined through a soakage test with an appropriate reduction factor (at least 0.5) applied to accommodate loss of performance over time;
- (c) Capacity to accommodate the maximum potential impermeable area;
- (d) Overland flow paths to accommodate flows in excess of the design storm;
- (e) Confirmation that the soakage system will not have an adverse effect on surrounding land and properties from land stability, seepage, or overland flow issues;
- (f) Soakage system to be located above static groundwater level;
- (g) Pre-treatment device to minimise silt ingress may be required;
- (h) Interception of hydrocarbons;
- (i) Access for maintenance.

For guidance on disposal using soakage on individual lots refer to NZBC clause E1/VM1.

The TA may require a geotechnical assessment to be carried out by an appropriately qualified geotechnical professional to determine the suitability of soil and groundwater characteristics for any proposed soakage system.

A discharge permit may be required from the regional council for discharge to soakage.

#### **C4.3.7.9**

*National and international references that may be able to be used in the design and maintenance of such systems are listed in Referenced Documents and Related Documents.*

#### **4.3.8 Natural and constructed waterways**

Where waterways are to be incorporated in the stormwater system, they shall be located within a reserve of sufficient width to contain the full design storm flow with a minimum freeboard of 500 mm.

Grass berms in reserves shall have a maximum side slope of 1 in 5 and additionally include a vehicular access berm for maintenance purposes.

Reserves should be designed to accommodate off-road pedestrian and cycle access for recreational use. Planted riparian margins should be provided each side of the waterway (see 7.2.4).

All channel infrastructure shall include protection against scour and erosion of the stream banks and stream bed.

If the watercourse is to be in private property and be maintained by the TA it shall be protected by an easement.

*Easements shall also be provided in favour of council over land set aside as secondary flow paths.*

### **4.3.9 Pipelines and culverts**

#### **4.3.9.1 Location and alignment of public mains**

The preferred location of public mains shall be within the road reserve or within other public land.

Where required by the TA easements shall be provided for stormwater pipelines located on private property.

A straight alignment between manholes (MHs) is required unless there are special circumstances. See 5.3.7.6 and 5.3.7.7 for further guidance on curved alignments for stormwater pipelines.

*Easements shall be provided in favour of the Council where any Council owned pipeline crosses private property, or to provide access over private property to the Council's assets, and around Council assets for the purposes of maintenance and operation.*

*Such easements shall be 3 metres wide in the case of pipelines or access, and shall provide at least 2 metres clearance around other Council assets e.g. manholes.*

*Where the pipes are laid to a depth of 2 metres or more, greater easement width may be required to facilitate maintenance.*

#### **4.3.9.2 Materials**

Appendix A sets out acceptable system uses for various pipe materials. Stormwater pipe types as listed, or as amended may be used for stormwater infrastructure.

For materials for which there is no New Zealand or Australian Standard the specific approval of the TA is required.

#### **4.3.9.3 Minimum pipe sizes**

*Minimum pipe sizes for pipes vested in council shall be:*

- (a) 300mm internal diameter for sump outlets.
- (b) 300mm internal diameter for stormwater mains.

#### **4.3.9.4 Minimum cover**

*Minimum cover to pipes shall be in accordance with manufacturer's recommendations, but not less than the following unless approved by the TA:*

- *Non trafficable - Road berms, reserves, grassed areas, private property: 600mm*
- *Trafficable - Carriageway (including shoulder and parking) and right of way: 900mm*
- *Sump Outlets: 450mm*

**4.3.9.5 Minimum gradients and flow velocities**

In flat areas gradients should be as steep as possible to control silt deposition. The minimum velocity should be at least 0.6 m/s at a flow of half the 50% AEP design flow. For velocities greater than 3.0 m/s see 5.3.5.6.

**4.3.9.6 Culverts**

In designing culverts the effects of inlet and tailwater controls shall be considered.

Culverts under fills shall be of suitable capacity to cope with the design storm with no surcharge at the inlet, unless the fill is part of a stormwater detention device or has been designed to act in surcharge. All culverts shall be provided with adequate wingwalls, headwalls, aprons, scour protection, removable debris traps or pits to prevent scouring or blocking. Special consideration shall be given to the effects of surcharging or blocking of culverts under fill.

Fish passage through culverts shall always be maintained.

Refer to the NZTA Bridge *manual* for waterway design at bridges and culverts.

**4.3.9.7 Inlets and outlets**

Where a pipeline discharges into a natural or constructed waterway, or vice versa, consideration shall be given to energy dissipation or losses, erosion control, and land instability. This is often achieved by an appropriately designed headwall structure.

For outlets the design shall ensure non-scouring velocities at the point of discharge. Acceptable outlet velocities will depend on soil conditions, but should not exceed 2m/s without specific provision for energy dissipation and velocity reduction.

Where inlets or outlets are located on or near natural waterways their appearance in the riparian landscape and likely effect on in-stream values shall be considered. Methods could include cutting off the pipe end at an oblique angle to match soil slope, constructing *concrete headwalls and wingwalls*, planting close to the structure, and locating outlets well back from the water's edge.

Direct discharge to a waterway or the sea may require a discharge consent from the regional council unless authorised by a comprehensive consent held by the TA, or is a permitted activity in a regional plan.

**4.3.9.8 Outfall water levels**

Where a pipeline or waterway discharges into a much larger system the peak flows generally do not coincide. Backwater profiles should produce satisfactory water levels when assessed as follows:

- (a) Determine the time of concentration and set the design rainfall event for the smaller system;
- (b) Determine the peak flow for the design event;
- (c) Determine receiving waterway peak water level for the design rainfall event in (a);
- (d) Starting with the level from (c) determine the smaller system profile at a flow of 75% of the flow from (b);
- (e) Determine the receiving waterway mean annual flood water level;
- (f) Starting with the level from (e) determine the smaller system water profile at the flow from (b);
- (g) Select the higher of the two profiles determined for design purposes.

Similarly, for tidal outfalls, peak flow may or may not coincide with extreme high tide levels. A full dynamic analysis and probability assessment may be required.

Sea level rise shall be taken into account (see 4.3.5.3).

**4.3.9.9 Subsoil drains**

Subsoil drains are installed to control groundwater levels. Perforated or slotted pipe used under all areas subject to vehicular traffic loads shall comply with NZTA specification F/2 and NZTA F/2 notes. It is good practice to provide regular inspection points.

Bedding and backfill material around a subsoil drain pipe shall be more free-draining than the in situ soil. If filter fabrics are used their susceptibility to clogging, thereby reducing the through flow, should be considered.

Groundwater control shall always be considered when an open drain is piped.

In the absence of any other more appropriate criterion the design flow for subsoil systems shall be based on a standard of 1 mm/h (2.78 L/s/ha).

Refer to manufacturer’s literature for information on pipe materials, filter fabrics, bedding, and filter design.

**4.3.9.10 Bulkheads for pipes on steep grades**

Bulkheads, or anti-scour blocks, shall be detailed on the design drawings and shall be in accordance with Appendix B drawing CM – 003. Spacing of bulkheads shall be:

**Table 4.4 - Spacing of bulkheads for pipes on steep grades**

Grade (%)	Requirement	Spacing (S) (m)
15 – 35	Concrete bulkhead	$S = 100/\text{Grade} (\%)$
>35	Special design	Refer to TA
NOTE – On grades flatter than above where scour is a problem, sand bags may be used to stabilise the trench backfill.		

**4.3.9.11 Trenchless technology**

See 5.3.6.8 and 5.3.6.9 for guidance on the use of trenchless technology.

**4.3.10 Manholes**

*Pipeline connections shall be made only at manholes.*

**4.3.10.1 Standard manholes**

Access chambers or MHs shall be provided at all changes of direction, gradient and pipe size, at branching lines and terminations and at a distance apart not exceeding 120 m unless approved otherwise. They shall be easily accessible and located clear of any boundary. All public mains shall terminate with a MH at the upstream end.

See 5.3.8.2 and 5.3.8.3 of this Standard for further guidance on the location of MHs.

On pipelines equal to or greater than 1 m diameter, the spacing of MHs may be extended with the approval of the TA.

Appendix B drawings CM – 004, CM – 005, and CM – 006 for manholes may be adopted for stormwater systems.

*All manholes greater than 5m depth shall be subject to specific design to ensure adequacy of structural strength and adequate safe access.*

*Stainless steel rungs or alternative access methods listed on Council's approved products list (Appendix A) shall be used. These rungs do not need to comply with the diameter of standard rungs. Refer to NZS/AS 1657.*

**4.3.10.2 Manhole materials**

*Manholes shall be reinforced concrete. Other materials may be considered on a case by case basis.*

**4.3.10.3 Size of manholes**

The standard internal diameter of circular MHs is 1050 mm and preferred nominal internal diameters are 1050 mm, 1200 mm, and 1500 mm. However, for shallow systems, DN 375/400 or 600 mm minimum diameter may be permitted (see 4.3.10.4).

When considering the appropriate MH diameter, consideration shall be given by the designer to the base layout to ensure hydraulic efficiency and adequate working space in the chamber. Where the effective working space is reduced by internal drop pipes, a larger diameter may be required. Where there are several inlets, consultation with the TA on the layout of the chamber is recommended.

The base layout of MHs shall comply with 5.3.8.4.2 of this Standard and Appendix B drawings CM – 004 and CM – 005.

**4.3.10.4 Shallow manholes (or mini manholes)**

For shallow systems (less than 1.2 m to invert) a DN 375/400 or 600 mm minimum diameter MH may be permitted subject to approval by the TA. Such small diameter MHs shall be classified as maintenance shafts (MSs) for the purposes of the spacing covered under this Standard. See Appendix B drawing CM – 005.

**4.3.10.5 Hydraulic flow in manholes**

In addition to the normal pipeline gradient all MHs on pipelines less than 1000 mm diameter shall have a minimum drop of 30 mm within the MH to compensate for the energy loss due to the flow through the MH. See 5.3.8.4.4 and 5.3.8.4.5 for further guidance.

**4.3.10.6 Manhole connections**

*All new connections into manholes shall be cut into the precast manhole wall by drilling or saw cutting. Breaking into a manhole by use of a heavy hammer or chisel is not permitted.*

Open cascade is permitted into MHs over 2.0 m in depth and for pipes up to and including 300 mm diameter providing the steps are clear of any cascade. Other situations may be considered and require TA approval.

The bases of all MHs shall be benched and haunched to a smooth finish to accommodate the inlet and outlet pipe.

New inlet pipes shall be cut back to the inside face of the MH and provided with a smooth finish. All chambers are to be made watertight with mortar around all openings.

Minor pipelines connecting to a MH at or below design water level in the MH shall do so at an angle of not greater than 90° to the main pipeline direction of inflow.

Minor pipelines connecting at above design water level may do so at any angle.

**4.3.10.7 Flotation**

In areas of high water table, all MHs shall be designed to provide a factor of safety against flotation of 1.25.

**4.3.10.8 Access**

*Access shall be provided to manholes which shall comply with the requirements AS/NZS2865:2001 Safe Working in a Confined Space NZS/AS1657 Fixed Platforms, Walkways, Stairways and Ladders Design Construction and Installation.*

*Where required by the TA, bolt-down metal access covers and grates (watertight type) shall be specified on MHs:*

- (a) *In systems where the possibility of surcharge exists; and*



- (b) *Along creeks subject to flooding above the level of the cover, in tidal areas, or in any location where surface waters could inundate the top of a MH.*

*Sealed entry holes with restricted access should be used in geothermal conditions and for deep manholes.*

#### **4.3.11 Stormwater Disposal**

- a) *Stormwater from Commercial, Industrial and Residential areas shall be directed to on site soakage, such as soakpits, vegetated swales, soakage basins, rainwater tanks, etc as approved by the TA.*
- b) *If ground conditions are unsuitable for on-site disposal or if on-site soakage can only be provided for a portion of the stormwater runoff from a Lot, the following will apply:*
- i) *Stormwater or excess stormwater shall be directed to manholes on Public mains, or to sumps as shown in Figure 4.2, or to kerb and channel as shown in Figure 4.1 if no Public stormwater reticulation is available as approved by the TA.*
  - ii) *Connection of stormwater to Public drainage will only be permitted where no other options exist and it can be demonstrated by the developer that the public system has sufficient capacity to take the additional flow without adverse effects.*
  - iii) *No discharge to the road reserve, parks, open spaces or to Public stormwater reticulation shall be made without the approval of the TA.*
  - iv) *Each connection shall be capable of serving all buildings and impervious areas within the Lot.*
  - v) *Unless otherwise approved by the TA, the minimum internal diameter of connections shall be:*
    - *100mm for residential lots.*
    - *150mm for commercial and industrial lots and connections serving two residential lots.*
    - *200mm for connections serving three or more residential lots.*
  - vi) *Where the stormwater pipeline is outside the lot to be served, a connection pipeline shall be extended inside the boundary of the lot and marked by a 50mm x 50mm timber stake extended 300mm above ground level and painted green.*
  - vii) *All connections shall be sealed by removable caps until such time as they are required.*
  - viii) *Connections shall be indicated accurately on as-built plans. Locations relative to boundaries, depth to invert and ground level shall be given as a minimum.*
  - ix) *The depth of the property connection shall be a minimum of 600mm at the property boundary.*

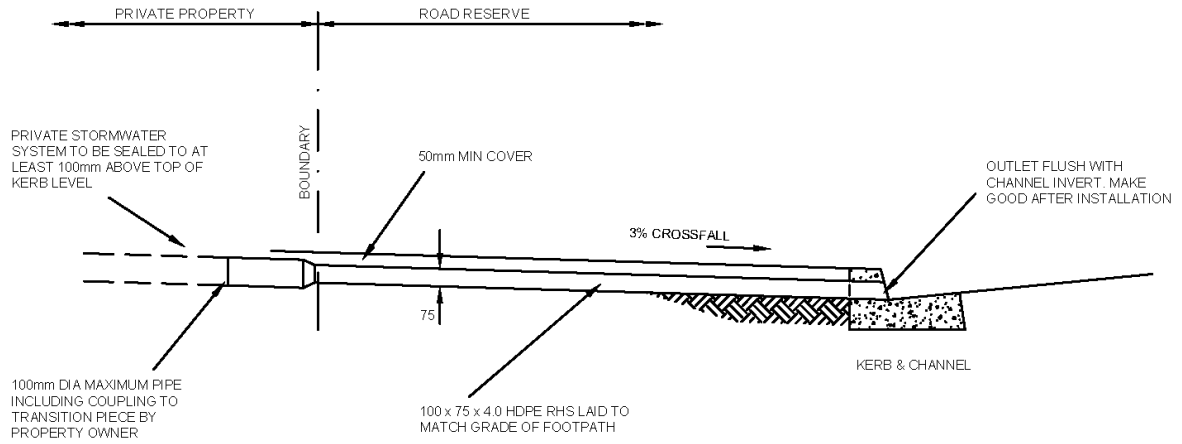

Figure 4.1 - Discharge to a kerb connection

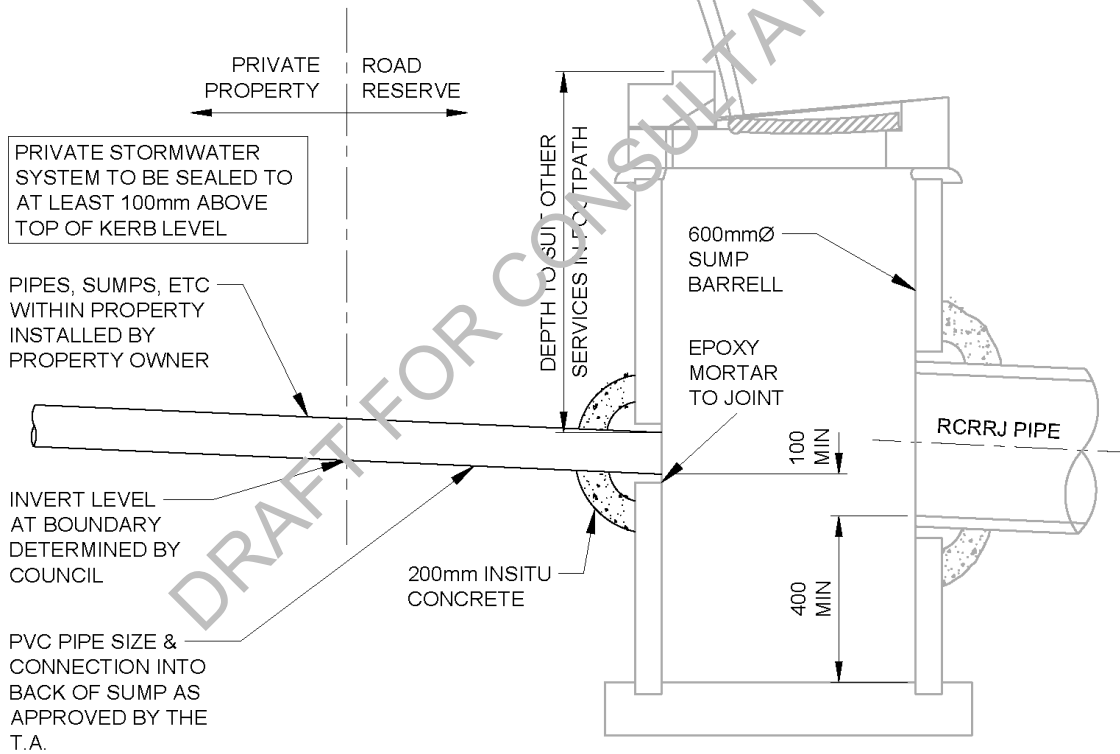

Figure 4.2 - Discharge to a sump

**4.3.12 Connection of lateral pipelines to public mains**

*All connections to stormwater mains will be via existing manhole or installation of a new manhole.*

**4.4 Approval of proposed infrastructure**

The approval process for land development and subdivision design and construction and documents and supporting information on stormwater drainage infrastructure to be provided at each stage of the process shall be in accordance with section 1 of this Standard.

**4.4.1 Approval process**

Stormwater infrastructure requires approval from the TA and unless the TA holds a comprehensive, or network consent for the catchment, consents from the regional council to discharge, divert, or dam water may also be required.

*In these circumstances developers are required:*

- (a) To consult with TAs prior to consent application;
- (b) To lodge applications with TAs at the same time so that land use and water-related resource consents can, if required, be dealt with at a joint hearing under s. 102 of the RMA.
- (c) *To delay the commencement of site works until a water/discharge permit from TRC has been granted, if required.*

**4.4.2 Information to be provided**

Specific information to be provided on any concept plans or scheme plans for development or subdivision incorporating stormwater infrastructure shall include:

- (a) The location of any natural waterways or wetlands within the site or in close proximity to a boundary. The location in plan and level of the water's edge and shoulder of the banks shall be indicated;
- (b) Typical pre-existing and post-development cross sections through any natural waterways or wetlands;
- (c) The proposed proximity of buildings to the water's edge or the shoulder of the banks, or both;
- (d) Clear identification of the extent of any river, stream, or coastal floodplains on, or in close proximity to the site and overland flow paths within the site; and
- (e) The level datum.

TAs may require some of the information following, particularly (h) and (i), in order to assess possible effects of a proposed development.

Applications for design approval shall include the information outlined in 1.8 of this Standard. In addition the following information shall be provided:

- (f) A plan showing the proposed location of existing and proposed stormwater infrastructure and flow paths;
- (g) Detailed long sections showing the levels and grades of proposed stormwater infrastructure in terms of datum;
- (h) Details and calculations prepared which demonstrate that agreed levels of service will be maintained. All applications to develop within a flood plain shall be supported by detailed calculations and plans to determine the floodplain boundaries and building floor levels to meet the freeboard requirements in 4.3.5.2;
- (i) Details and calculations prepared which clearly indicate any impact on adjacent area or catchment that the proposed infrastructure may have; and

- (j) Operations and maintenance guidelines for any water quantity and or quality control structures shall be submitted to the TA for design approval along with other documents. The guidelines should describe the design objectives of the structure, describe all major features, explain operations such as recommended means of sediment removal and disposal, identify key design criteria, and identify on-going management and maintenance requirements such as plant establishment, vegetation control, and nuisance control.

## **4.5 Construction**

### **4.5.1 Pipeline construction**

The construction of pipelines shall be carried out in accordance with the requirements of AS/NZS 2032 (PVC), AS/NZS 2033 (PE), AS/NZS 2566 Parts 1 and 2 (all buried flexible pipelines), or AS/NZS 3725 (concrete pipes).

### **4.5.2 Trenching**

Guidance is provided in Appendix B drawings CM – 001 and CM – 002.

Where a pipeline is to be constructed through areas with unsuitable foundations such material shall be removed and replaced with other approved material or alternatively, other methods of construction shall be carried out to the approval of the TA to provide an adequate foundation, and side support if required, for the pipeline.

### **4.5.3 Reinstatement**

Areas where construction has taken place shall be reinstated to the condition required by the TA.

### **4.5.4 Inspection and acceptance**

Pipe systems of 1200 mm diameter or less shall be inspected using closed circuit television (CCTV) prior to acceptance by the TA.

CCTV inspections and deliverables shall be in accordance with New Zealand pipe inspection manual and the requirements of the TA.

The TA may, at its discretion, also require a water test to be carried out. Testing shall be carried out as specified in Appendix C.

## **4.6 Catchment Management Plan – Sample Contents**

### *INTRODUCTION*

*What is a CMP? (Description of process)*

*Reasons of this study*

*Reference for previous studies*

*Past flooding (Description / data on significant past flood events and their effects)*

*Planning Framework (Zoning, existing consents)*

*Existing standards (Stormwater design, flood protection)*

### *CATCHMENT AREA*

*Catchment Description (Location, catchment map, features)*

*Geotechnical Assessment (Soils, stability, erosion, occurring or potential)*

*Level of Development (Definition of existing development and growth scenarios to be considered)*

### *CALCULATION OF PEAK FLOWS*

*Hydrological Analysis*

*Local Rain gauges*

*Derivation of depth-duration-frequency data*

*Local stream gauging data*

*Rainfall loss rates*  
*Hydrologic modelling*  
*Calibration of hydrologic model*  
*Sensitivity analysis*  
*Discussion of results*

#### **CALCULATION OF PEAK WATER LEVELS**

*Hydraulic modelling*  
*Calibration (Comparison with known flood levels)*  
*Influence of bridges and culverts*  
*Tidal effects*  
*Greenhouse effects*  
*Design flood levels (for each development scenario)*  
*Discussion of results*

#### **ASSESSMENT OF EXISTING SYSTEM**

*Pipe Reticulation (Capacity / Condition)*  
*Open channels*  
*Hydraulic structures*

#### **STORMWATER QUALITY ISSUES / OPPORTUNITIES**

*Water quality (Sampling and analysis, benthic indicators. Comparison with relevant standards)*  
*Ecological assessment*  
*Opportunity for stormwater treatment*

#### **MANAGEMENT OPTIONS**

*Non-structural options (Policy, District Plan rules, etc.)*  
*Structural options (One section of report for each option discussing feasibility, costs, advantages, disadvantages, etc)*

#### **SUMMARY AND RECOMMENDATIONS**

*Appendices*  
*Tables of peak water levels at each cross-section for each scenario / management option*  
*Summary of existing buildings at risk*  
*Flood hazard maps (May need separate plans for each development scenario / management option)*  
*Estimated costs of management options*  
*Record of consultation and major outcomes*

*The final management plan will cover similar items to those above but will generally be specifically tailored to a single preferred management strategy. The preferred strategy will be confirmed during the consultation and political input occurring between the two phases.*

## 5 WASTEWATER

### 5.1 Scope

This section sets out requirements for the design and construction of wastewater systems for land development and subdivision. Section 5 primarily addresses reticulated systems, but reference is also made to on-site wastewater systems where applicable.

If the scope of the development is sufficiently large to include its own pumping station, then reference should be made to WSA 04.

### 5.2 General

#### 5.2.1 Objectives

The objectives of the design are to ensure that the wastewater system is functional and complies with the requirements of the TA's wastewater systems.

In principle the wastewater system shall provide:

- (a) A single gravity connection for each property;
- (b) A level of service to the TA's customers in accordance with the authority's policies;
- (c) Minimal adverse environmental and community impact;
- (d) Compliance with environmental requirements;
- (e) Compliance with statutory OSH requirements;
- (f) Adequate hydraulic capacity to service the full catchment;
- (g) Long service life with minimal maintenance and least life-cycle cost;
- (h) Zero level of pipeline infiltration on commissioning of pipes;
- (i) Low level of pipeline infiltration/exfiltration over the life of the system;
- (j) Resistance to entry of tree roots;
- (k) Resistance to internal and external corrosion and chemical degradation;
- (l) Structural strength to resist applied loads; and
- (m) 'Whole of life' costs that are acceptable to the TA.
- (n) *Sewers deeper than 2.5 metres are to be avoided because of maintenance reasons.*
- (o) *Sewer networks must be designed to ensure that the length of sewer laterals is the shortest possible distance, perpendicular to the sewer drain.*

#### 5.2.2 Referenced documents and relevant guidelines

Wastewater designs shall incorporate all the special requirements of the TA and shall be in accordance with the most appropriate Standards, codes, and guidelines including those set out in Referenced Documents. Related Documents lists additional material that may be useful.

### 5.3 Design

#### 5.3.1 Design life

All wastewater systems shall be designed and constructed for an asset life of at least 100 years. Some components such as pumps, valves, and control equipment may require earlier renovation or replacement. Refer to WSA 02 for the classification of life expectancy for various components in conventional gravity systems.

### 5.3.2 Structure plan

The TA may provide a structure plan setting out certain information to be used in design, such as flows, sizing, upstream controls, recommended pipe layout, or particular requirements of the TA. Where a structure plan is not provided, the designer shall determine this information by investigation using this Standard and engineering principles.

### 5.3.3 Future development

Where further subdivision, upstream of the one under consideration, is provided for in the district or regional plan, *the TA shall require wastewater infrastructure* to be constructed to the upper limits of the subdivision to provide for the needs of this development.

Additionally, the TA may require additional capacity to be provided in the wastewater system to cater for existing or future development upstream. Peak flows and cleansing velocities should be taken into account when designing for additional latent capacity.

All infrastructure proposed to service future development will require the approval of the TA.

### 5.3.4 System design

#### 5.3.4.1 Catchment design

Pipes within any project area shall be designed to be consistent with the optimum design for the entire catchment area and any future extension of the system shall be accommodated. This may affect the pipe location, diameter, depth, and maintenance structure location and layout. Designers shall adopt best practice to ensure a system with lowest life-cycle cost.

Pipes shall be designed with sufficient depth and capacity to cater for all existing and possible development of the catchment. Where future extension of the pipe is possible, it may be necessary to carry out preliminary designs for large areas of subdivided and unsubdivided land. This design shall use safety factors defined by the TA for hypothetical subdivision and service for layouts to determine the necessary depth and diameter for an extension.

#### 5.3.4.2 Extent of infrastructure

Where pipes are to be extended in the future, the ends of pipes shall extend past the far boundary of the development by a distance equivalent to the depth to invert and be capped off, unless otherwise agreed to by the TA. This ensures that a future extension of the pipe does not require unnecessary excavation within lots or streetscapes already developed.

#### 5.3.4.3 Topographical considerations

In steep terrain the location of pipes is governed by topography. Gravity pipelines operating against natural fall create a need for deep installations which may require trenchless installation. The pipe layout shall conform to natural fall as far as possible.

#### 5.3.4.4 Geotechnical investigations

The designer shall take into account any geotechnical requirements determined under section 2 of this Standard.

### 5.3.5 Design criteria

#### 5.3.5.1 Design flow

The design flow comprises domestic wastewater, industrial wastewater, infiltration, and direct ingress of stormwater.

The design flow shall be calculated by the method nominated by the TA. In the absence of information from the TA the following design parameters are recommended:

- (a) Residential flows
  - (i) *ADWF to be 250 L/p/day*

- (ii) Dry weather diurnal PF of 2.5
- (iii) Dilution/infiltration factor of 2 for wet weather
- (iv) Number of people per dwelling = 2.6;

For undeveloped zoned land the design flows shall be calculated by allowing 30% of the land area for associated infrastructure and dividing the remaining land area by the minimum lot size allowable under the District Plan.

**C5.3.5.1(a)**

For small contributing catchments, PFs can be significantly higher but, due to the requirement for a minimum pipe size of DN 150, such flows will not govern the design.

- (b) Commercial and industrial flows  
Where flows from a particular industry or commercial development are known they should be used as the basis of design. Where there is no specific flow information available and the TA has no design guide, Table 5.1 is recommended as a design basis. These flows include both sanitary wastewater and trade wastes and include peaking factors.

**5.3.5.2 Hydraulic design of pipelines**

The hydraulic design of wastewater pipes should be based on either the Colebrook-White formula or the Manning formula. The coefficients to be applied for pipe roughness shall be  $k = 1.5$  for Colebrook-White or  $n = 0.013$  for Manning's. These coefficients shall be used irrespective of the pipe material.

**5.3.5.3 Minimum pipe sizes**

**C5.3.5.3**

For infill situations, particularly where upgrading of existing DN 100 connections in sound condition and at reasonable grades would be impractical, it is common practice for up to six dwelling units to use the existing connection (maximum of four dwellings in the Stratford District). However, such connections would not normally be taken over as public pipes by the TA.

**Table 5.1 - Commercial and industrial flows**

Industry type (Water usage)	Design flow (Litre/second/hectare)
Light	0.4
Medium	0.7
Heavy	1.3

**Table 5.2 – Deleted (Guide to roughness coefficients for gravity sewer lines)**

**Table 5.3 - Minimum pipe sizes for wastewater reticulation and property connections**

Pipe	Minimum size DN (mm)
Connection servicing 1 lot	100
Connection servicing more than 1 lot	150
Connection servicing commercial and industrial lots	100 <sup>1</sup>
Reticulation servicing residential lots	150
NOTE – In practical terms, in a catchment not exceeding 250 dwelling units, and where no pumping station is involved, DN 150 pipes laid within the limits of Tables 5.4 and 5.5 will be adequate without specific hydraulic design.	
<sup>1</sup> Connections serving commercial and industrial lots are to have minimum pipe size determined by flow data.	



**5.3.5.4 Limitation on pipe size reduction**

In no circumstances shall the pipe size be reduced on any downstream section.

**5.3.5.5 Minimum grades for self-cleaning**

Self-cleaning of grit and debris shall be achieved by providing minimum grades specified in Tables 5.4 and 5.5.

*The minimum velocity for any pipeline shall not be less than 0.6m/s under full pipe conditions.*

*Rising mains shall be designed with a minimum flow velocity of 1 m/s at peak pumping rate.*

**Table 5.4 - Minimum grades for wastewater pipes**

Pipe Size	Absolute minimum Grade
DN	%
150	0.67
225	0.44
300	0.33

**Table 5.5 - Minimum grades for property connections and permanent ends**

Situation	Minimum grade (%)
DN 100 property connections	1.25
DN 150 property connections	1.20
Permanent upstream ends of DN 150, 200, and 300 pipes in residential areas with population $\leq$ 20 persons	1.00

**5.3.5.6 Maximum velocity**

The preferred maximum velocity for peak wet weather flow is 3.0 m/s. Where a steep grade that will cause a velocity greater than 3.0 m/s is unavoidable refer to WSA 02 for precautions and design procedures.

*Rising mains shall be designed with a maximum flow velocity of 2m/s at peak pumping rate.*

**5.3.5.7 Gravity wastewater applications**

See Appendix A for appropriate gravity pipe Standards for wastewater.

The pipe shall be designed to:

- Have adequate capacity, grades, and diameters;
- Have adequate grade for self-cleaning;
- Be deep enough to provide gravity service to all lots;
- Comply with minimum depth requirements to ensure mechanical protection and safety from excavation;
- Avoid all underground services, while maintaining all the necessary clearances; and
- Allow for various drops and losses through MHs.

**5.3.5.8 Pressure and vacuum wastewater applications**

The introduction of pressure or vacuum systems into a network requires approval from the TA. See Appendix A for appropriate pressure pipe and fittings Standards for wastewater. See also 5.3.12.

Design of pressure and vacuum wastewater applications shall consider the following:

- (a) Selection of pipe material and PN class shall take account of design for dynamic operation stresses (fatigue), and water temperature. Refer to Plastics Industry Pipe Association of Australia Ltd (PIPA) guidelines for PVC and PE pipes (<http://www.pipa.com.au>), or WSA-07;
- (b) Sump and pump design;
- (c) Maintenance requirements;
- (d) Access for servicing and maintenance.

**5.3.6 Structural design****5.3.6.1 General**

The design shall be in accordance with AS/NZS 2566.1, or AS/NZS 3725, including the structural design commentary AS/NZS 2566.1 Supplement 1. Details of the final design requirements shall be shown on the drawings.

**5.3.6.2 Seismic design**

All pipes and structures shall be designed with adequate flexibility and special provisions to minimise risk of damage during earthquake. Historical experience in New Zealand earthquake events suggests that suitable pipe options, in seismically active areas, may include rubber ring joint PVC or PE pipes. Specially designed flexible joints shall be provided at all junctions between pipes and rigid structures.

**5.3.6.3 Structural consideration**

Pipelines shall be designed to withstand all the forces and load combinations to which they may be exposed including internal forces, external forces, temperature effects, settlement, and combined stresses.

**5.3.6.4 Internal forces**

Pipelines shall be designed for the range of expected pressures, including transient conditions (surge and fatigue) and maximum static head conditions. In the case of transient conditions, the amplitude and frequency shall be estimated. Mains subject to negative pressure shall be designed to withstand a transient pressure of at least 50 kPa below atmospheric pressure.

**5.3.6.5 External forces**

The external forces to be taken into account shall include:

- (a) Trench fill loadings (vertical and horizontal forces due to earth loadings);
- (b) Surcharge;
- (c) Groundwater;
- (d) Dead weight of the pipe and the contained water;
- (e) Other forces arising during installation;
- (f) Traffic loads;
- (g) Temperature (expansion/contraction).

The consequences of external forces on local supports of pipelines shall also be considered.

**5.3.6.6 Geotechnical investigations**

The designer should take into account any geotechnical requirements determined under section 2 of this Standard. Where required, standard special foundation conditions shall be referenced on the drawings.

**5.3.6.7 Pipe selection for special conditions**

Pipeline materials and jointing systems shall be selected and specified to ensure:

- (a) Structural adequacy for the ground conditions and water temperature;
- (b) Water quality considering the lining material;
- (c) Compatibility with aggressive or contaminated ground;
- (d) Suitability for the geotechnical conditions;
- (e) Compliance with the TA's requirements.

**5.3.6.8 Trenchless technology**

Trenchless technology may be preferable or required by the TA as appropriate for alignments passing through or under:

- (a) Environmentally sensitive areas;
- (b) Built-up or congested areas to minimise disruption and reinstatement;
- (c) Railway and major road crossings;
- (d) Significant vegetation;
- (e) Vehicle crossings.

Wastewater pipes used for trenchless installation shall have suitable mechanically restrained joints, specifically designed for trenchless application, which may include integral restraint, seal systems, or heat fusion welded joints.

Trenchless installation methods may include:

For new pipes:

- (f) Horizontal directional drilling (HDD) (PVC with restraint joint/fusion welded PE)
- (g) Uncased auger boring/pilot bore microtunnelling/guided boring (PVC with restraint joint/fusion welded PE)
- (h) Pipe jacking (GRP/ vitrified clay (VC)/ reinforced concrete)

For pipe rehabilitation/renovation:

- (i) Slip lining/grouting (PVC with restraint joint/fusion welded PE)
- (j) Closed slip lining (PVC with restraint joint/fusion welded PE)
- (k) Static pipe bursting (PVC with restraint joint/fusion welded PE)
- (l) Reaming/pipe eating/inline removal (PVC with restraint joint/fusion welded PE)
- (m) Soil displacement/impact moling (fusion welded PE)
- (n) Cured in place pipe (thermoset resin with fabric tube)

Any trenchless technology and installation methodology shall be chosen to be compatible with achieving the required gravity pipe gradient – refer to manufacturer's and installer's recommendations.

The following details including location of access pits and exit points shall be submitted to the TA for approval:

- (o) Clearances from services and obstructions;
- (p) The depth at which the pipeline is to be laid to ensure minimum cover is maintained;
- (q) The pipe support and ground compaction;
- (r) How pipes will be protected from damage during construction;

- (s) Any assessed risk to abutting surface and underground structures.

*The design gradient for near horizontal bores shall not be less than 1.5%*

**C5.3.6.8**

*Further information on trenchless technologies may be found in 'Trenchless technology for installation of cables and pipelines' (Stein), 'Trenchless technology – Pipeline and utility design, construction, and renewal' (Najafi), and 'Guidelines for horizontal directional drilling, pipe bursting, microtunnelling and pipe jacking' (Australasian Society for Trenchless Technology).*

**5.3.6.9 Marking tape or pipe detection tape**

Appropriate marking tape or detection tape shall be installed at the top of the embedment zone, or tied to the pipe during HDD, to aid future location of the pipe. Refer to AS/NZS 2032 Section 5.3.15 and Figure 5.1.

**5.3.7 System layout**

**5.3.7.1 Pipe location**

The preferred layout/location of pipes within roads, public reserves, and private property may vary and shall be to the requirements of each TA.

Pipes should be positioned as follows:

- (a) Within the street according to the locally applicable utilities allocation code. In the absence of a code, a location clear of carriageways is preferred;
- (b) Within public land with the permission of the controlling authority;
- (c) Within reserves outside the 1 in 100-year flood area;
- (d) Within private property parallel to front, rear, or side boundaries.

*Easements shall be provided in favour of the Council where any Council owned pipeline crosses private property, or to provide access over private property to the Council's assets, and around Council assets for the purposes of maintenance and operation.*

*Such easements shall be 3 metres wide in the case of pipelines or access, and shall provide at least 2 metres clearance around other Council assets e.g. manholes.*

*Where the pipes are laid to a depth of 2 metres or more, greater easement width may be required to facilitate maintenance.*

**5.3.7.2 Materials**

Appendix A sets out various acceptable pipe and fittings materials for wastewater system uses.

**5.3.7.3 Pipes in reserves and public open space**

Pipes in reserves and public open space shall be located in accordance with the TA's requirements.

Crossings of roads, railway lines, waterways, and underground services shall, as far as practicable, be at right angles.

**5.3.7.4 Pipes in private property**

Where pipes are designed to traverse any vacant or occupied public or private properties, the design shall as far as practicable allow for possible future building plans, preclude maintenance structures and specify physical protection of the pipe within or adjacent to the normal building areas and all engineering features (existing or likely) on the site, such as retaining walls.

The design shall allow access for all equipment required for construction and future maintenance. Except where obstructions or topography dictate otherwise, pipes shall run parallel to boundaries at minimum offsets of 1.5 m.

Where pipes are designed to traverse properties containing existing structures such as retaining walls, buildings, and swimming pools, the current and future stability of the structure shall be considered. Pipes adjacent to existing buildings and structures shall be located clear of the 'zone of influence' of the foundations. If this is not possible, protection of the pipe and associated structures shall be specified for evaluation and approval by the TA.

*Where pipes to be vested to the TA are designed to traverse private properties, they shall be protected by legal easements in gross. Where there are no easements, all pipes for public drainage are protected under the Local Government Act 2002.*

**5.3.7.5 Minimum cover**

*In the New Plymouth District pipelines shall have minimum cover of 900mm in all Council owned land and private property.*

*Where minimum cover cannot be achieved specific design will be required and reduced minimum cover shall be subject to TA approval.*

**5.3.7.6 Horizontal curves**

*Horizontal curves will not generally be accepted except where site conditions do not allow straight alignments. They will not be accepted solely on the grounds of cost saving.* Horizontal curves shall only be used where authorised by the TA.

The term 'curved pipes' is used to describe either cold bending of flexible pipe during installation or small deflections at joints for rubber ring jointed flexible and rigid pipes. The radius of curvature and pipe deflection shall meet manufacturer's specifications. Curved alignments are used in curved streets to conform with other services and to negotiate obstructions, particularly in easements. The use of curves in locations other than curved street alignments shall be justified by significant savings in life-cycle cost. The straight line pipe is usually preferred as it is easier and cheaper to set out, construct, locate, and maintain in the future.

**5.3.7.7 Vertical curves**

Vertical curves may be specified where circumstances provide a significant saving or where maintenance structures would be unsuitable or inconvenient. The curvature limitations for vertical curves are the same as those for horizontal curves in 5.3.7.6.

*Vertical curves will not generally be accepted except where site conditions do not allow straight alignments. They will not be accepted solely on the grounds of cost saving.*

**5.3.7.8 Underground services**

The location of underground services affecting the proposed pipe alignment shall be determined. Where pipes will cross other services, the depth of those services shall be investigated, and exposed where necessary. Services upstream of the project area may affect the design. A future extension of the pipe that will cross existing and proposed upstream services may determine the level for the current project infrastructure.

**5.3.7.9 Clearance from underground services**

Where a pipe is designed to be located in a road which contains other services, the clearance between the pipe and the other services shall comply with SNZ HB 2002, unless the TA has its own specific requirements.

For normal trenching and trenchless technology installation, clearance from other service utility assets shall not be less than the minimum vertical and horizontal clearances shown in Table 5.6. Written agreement on reduced clearances and clearances for shared trenching shall be obtained from the TA and the relevant service owner.

**Table 5.6 - Clearances between wastewater pipes and other underground services**

Utility (Existing service)	Minimum horizontal clearance for new pipe size $\leq$ DN 300 (mm)	Minimum vertical clearance <sup>(1)</sup> (mm)
Gas mains	300 <sup>(2)</sup>	150
Telecommunication conduits and cables	300 <sup>(2)</sup>	150
Electricity conduits and cables	500	225
Drains	300 <sup>(2)</sup>	150
Water mains	1000 <sup>(3)</sup> /600	500
NOTE –		
(1) Vertical clearances apply when wastewater pipes and other underground services cross one another, except in the case of water mains when a vertical separation shall always be maintained, even when the wastewater pipe and water main are parallel. The wastewater pipe should always be located below the water main to minimise the possibility of backflow contamination in the event of a main break.		
(2) Clearances can be further reduced to 150 mm for distances up to 2 m when passing installations such as poles, pits, and small structures, providing the structure is not destabilised in the process.		
(3) When the wastewater pipe is at the minimum vertical clearance below the water main (500 mm) maintain a minimum horizontal clearance of 1000 mm. This minimum horizontal clearance can be progressively reduced to 600 mm as the vertical clearance increases to 750 mm.		

**5.3.7.10 Clearance from structures**

Pipes adjacent to existing buildings and structures shall be located clear of the 'zone of influence' of the building foundations. If this is not possible, a specific design shall be undertaken to cover the following:

- (a) Protection of the pipeline;
- (b) Long term maintenance access for the pipeline; and
- (c) Protection of the existing structure or building.

The protection shall be specified by the designer for evaluation and acceptance by the TA.

*The location of buildings or structures over or near an existing sewer is subject to the requirements of each council's bylaws.*

*No building shall be built over any buried public services whether on public or private land within the New Plymouth District.*

**5.3.7.11 Bulkheads for pipes on steep grades**

For bulkheads, or anti-scour blocks, see 4.3.9.10 and Appendix B drawing CM – 003.

**5.3.8 Maintenance structures****5.3.8.1 General**

This describes the requirements for structures which permit access to the wastewater system for maintenance.

Maintenance structures include:

- (a) Manholes (or maintenance holes) (MHs);
- (b) Maintenance shafts (MSs); and
- (c) Terminal maintenance shafts (TMSs).

*Maintenance Shafts and Terminal Maintenance Shafts are not acceptable in New Plymouth District. Maintenance Shafts and Terminal Maintenance Shafts are accepted in South Taranaki District.*

**5.3.8.2 Location of maintenance structures**

The selection of a suitable location for maintenance structures may influence the pipe alignment. Generally, a minimum clearance of 1.0 m should be provided around maintenance structures clear of the opening to facilitate maintenance and rescue. The TA may determine other specific requirements subject to the individual site characteristics.

The design shall include maintenance structures at the following locations:

- (a) Intersection of pipes except for junctions between mains and property connections;
- (b) Changes of pipe size;
- (c) Changes of pipe direction, except where horizontal curves are used;
- (d) Changes of pipe grade, except where vertical curves are used;
- (e) Combined changes of pipe direction and grade, except where compound curves are used;
- (f) Changes of pipe invert level;
- (g) Changes of pipe material, except for repair/maintenance locations;
- (h) Permanent or temporary ends of a pipe;
- (i) Discharge of a pressure main into a gravity pipe.

Table 5.7 summarises maintenance structure options for wastewater reticulation.

**Table 5.7 - Acceptable MH, MS, and TMS options for wastewater reticulation**

Application	Acceptable options <sup>(1)</sup>		
	MH	MS	TMS
Intersection of pipes <sup>(2)</sup>	YES	NO	NO
Change of pipe grade at same level	YES	YES for DN 150 pipe only and using vertical bend	NO
Change of grade at different level	YES MH with internal/external drops	NO	NO
Change in pipe size	YES MH is the only option	NO	NO
Change in horizontal direction	YES within permissible deflection at MH	YES MS prefabricated units or MS used with horizontal bends of max 33° deflection	YES for DN 150 pipe only
Change of pipe material	YES	NO	NO
Permanent end of a pipe <sup>(3)</sup>	YES	YES	YES
Pressure main discharge point	YES MH is the only option and shall include a vent	NO	NO

Application	Acceptable options <sup>(1)</sup>		
	MH	MS	TMS
<p>NOTES –</p> <p>Where person entry is required down to the level of the pipe, a MH is the only option.</p> <p>This table refers to reticulation mains. DN 100 connections can be made to any maintenance structure or, using a proprietary junction, at any point along the main.</p> <p>Some TAs permit the use of London Junction or Rodding Eye at the end of the pipe, but it is recommended that TMSs are used.</p> <p><i>Maintenance Shafts and Terminal Maintenance Shafts shall not be used within the New Plymouth District.</i></p>			

**5.3.8.3 Maintenance structure spacing**

For reticulation pipes, the maximum distance between any two consecutive maintenance structures shall be 120 m.

*A manhole shall be provided at the head of all public sewerage systems.*

**5.3.8.4 Manholes**

*All new connections into manholes shall be cut into the precast manhole wall by drilling or saw cutting. Breaking into a manhole by use of a heavy hammer or chisel is not permitted.*

**5.3.8.4.1 Manhole materials**

MHs may be manufactured in concrete, or from suitable plastics materials, including GRP, polyethylene, PVC or polypropylene, or from concrete/plastic lined composites.

MH materials selected shall be suitable for the level of aggressiveness of the wastewater and surrounding groundwater.

**5.3.8.4.2 Base layout**

Each MH base shall have:

- (a) One minimum standing area of 350 mm x 350 mm or of 350 mm diameter (where the ladder or step irons are located), and a second minimum width standing area of 250 mm x 250 mm or of 250 mm in diameter, as shown in Appendix B drawing CM – 004;
- (b) A minimum working space of 750 mm clear of drop pipes, ladders, and step irons; and
- (c) Channels with a minimum inside channel wall radius of 300 mm (in plan).

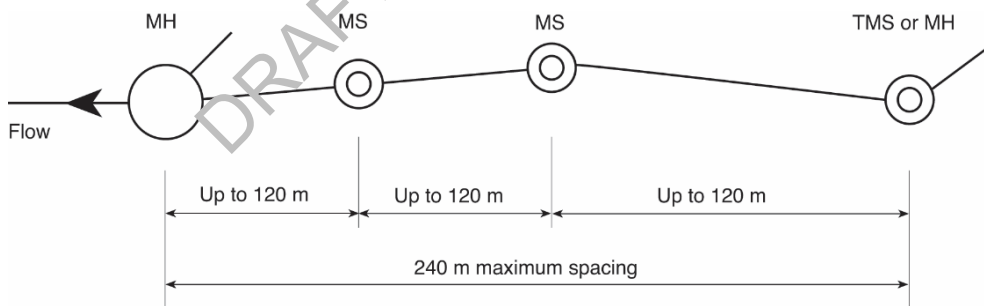

**Figure 5.1 - Multiple MSs between MH and 'last' MH/TMS**

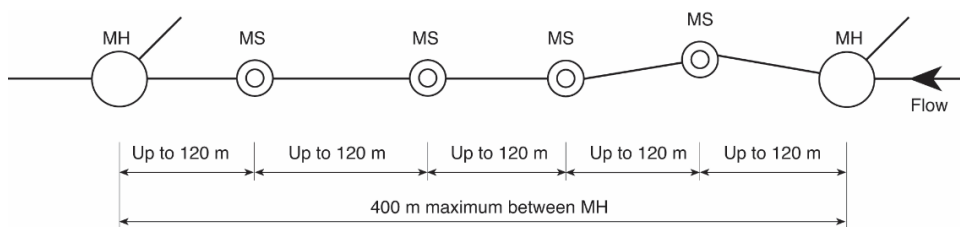

**Figure 5.2 - Multiple MSs between consecutive MHs**



**5.3.8.4.3 Allowable deflection through MHs**

A maximum allowable deflection through a MH shall comply with Table 5.8.

**5.3.8.4.4 Internal falls through MHs**

The minimum internal fall through a MH shall comply with Table 5.9.

Where the outlet diameter at a MH is greater than the inlet diameter, the minimum fall through the MH shall be not less than the difference in diameter of the two pipes, in which case the pipes shall be aligned soffit to soffit.

On pipes where the internal fall across the base of the MH is not achievable due to a large difference between the levels of incoming and outgoing pipes (see Appendix B drawing CM – 005), then internal or external drops shall be provided.

*Internal dropper pipes in manholes may only be used with prior approval by the TA.*

**Table 5.8 - Maximum allowable deflections through MHs**

Pipe size DN	Maximum deflection Degrees (°)
150 – 300	Up to 120° for internal fall along MH channel – see Table 5.9
150 – 300	Up to 150° where there is a large fall at MH using an internal or external drop structure

**Table 5.9 - Minimum internal fall through MH joining pipes of same diameter**

Deflection angle at MH Degrees (°)	Minimum internal fall (mm)
0 to 30	30
>30 to 60	50
>60 to 120	80

**5.3.8.4.5 Effect of steep grades on MHs**

Where a pipe of grade >7% drains to a MH, the following precautions shall be taken if the topography and the connection pipes allow for:

- No change of grade is permitted at inlet to a MH;
- Steep grades are to be continuous through the MH at the same grade;
- Depth of MH is to exceed 1.5 m to invert for DN 150, DN 200, and DN 225 pipes;
- Depth of MH is to exceed 2.0 m deep for DN 300 pipes;
- Change of direction at the MH is not to exceed 45°;
- No drop junctions or verticals are to be incorporated in the MH;
- Inside radius of channel inside the MH is to be greater than 6 times the pipe diameter; and
- Benching is to be taken 150 mm above the top of the inlet pipe.

To avoid excessively deep channels within MHs, steep grades (>7%) shall be 'graded-out' at the design phase where practicable.

Grading the channel of the MH shall be limited to falls through MHs of up to 0.15 m. Where the depth of the channel within the MH would be greater than 2 x pipe diameter, then an internal or external drop structure shall be provided.

**C5.3.8.4.5**

*For further guidance on handling steep grades, refer to WSA 02.*

**5.3.8.4.6 Flotation**

In areas of high water table, all MHs shall be designed to provide a factor of safety against flotation of 1.25.

**5.3.8.4.7 Covers**

Watertight MH covers with a minimum clear opening of 600 mm in diameter, complying with AS 3996, shall be used, unless the TA has an alternative standard. AS 3996 gives direction for the class of cover for particular locations and applications. (See Appendix B drawing CM – 004.)

**5.3.8.4.8 Bolt-down covers**

Where required by the TA, bolt-down metal access covers (watertight type) shall be specified on MHs:

- (a) In systems where the possibility of surcharge exists; and
- (b) Along creeks subject to flooding above the level of the cover, in tidal areas, or in any location where surface waters could inundate the top of a MH.

Sealed entry holes with restricted access should be used in geothermal conditions and for deep manholes.

MHs should, where practicable, be located on ground that is at least 300 mm above the 1 in 100-year flood level. Where this is not practicable, bolt-down access covers may be specified by the TA. It will also be necessary to specify the tying together of MH components where bolt-down covers are specified and precast components are used.

**5.3.8.4.9 Access to Manholes**

*Access shall be provided to manholes which shall comply with the requirements of AS/NZS2865:2001 Safe Working in a Confined Space NZS/AS1657 Fixed Platforms, Walkways, Stairways and Ladders Design Construction and Installation.*

**5.3.8.5 Maintenance shafts**

*Maintenance Shafts are not acceptable in New Plymouth District. Maintenance Shafts are accepted in South Taranaki District.*

Where maintenance shafts (MSs) have been approved by the TA, and where it is expected that human access below ground will not be required, MSs can be used on DN 150, DN 200, and DN 225 pipes as an alternative to MHs, providing 5.3.8.5.1 and 5.3.8.5.2 are satisfied. See Appendix B drawings WW – 001, WW – 003, and WW – 004.

Typical MS configurations are:

- (a) Straight through MSs; and
- (b) Angled MSs – see 5.3.8.5.2(a).

MSs can also be used in conjunction with a TMS (see 5.3.8.6).

**5.3.8.5.1 Limiting conditions**

The following conditions apply to the use of MSs:

- (a) MSs shall only be used on DN 150, DN 200, and DN 225 pipes;
- (b) MSs shall not be used instead of MHs at junctions;
- (c) Depth of MSs shall:
  - (i) Be within the allowable depth limit for the particular pipeline system
  - (ii) Not exceed the MS manufacturer's stated allowable depth limit, and
  - (iii) Be within the depth limit imposed by the TA;
- (d) MSs shall be restricted to pipeline gradients and depths where the deviation from vertical of the MS riser shaft (that is, projected centre line of base to centre line at surface) is a maximum of 0.3 m measured at the surface;
- (e) MSs shall not be used at discharge points of pumping mains.

**5.3.8.5.2 Design parameters**

MSs shall only be used at the design locations detailed in Figures 5.1 and 5.2. The following requirements shall apply:

- (a) Directional and gradient changes at MSs shall be achieved by using either:
  - (i) Close-coupled horizontal or vertical manufactured bends immediately adjacent to the MS (maximum horizontal deviation of 33°), or
  - (ii) MS units specially manufactured with internal horizontal or vertical angles to suit design requirements (maximum horizontal deviation of 90°);
- (b) MSs at changes of grade shall be located on the pipe with the lesser of the two gradients to minimise the deviation from the vertical of the riser shaft;
- (c) Straight through type and angled MSs can incorporate up to two higher level property connections discharging directly into the riser shaft.

For construction details see Appendix B drawings WW – 003 and WW – 004.

**5.3.8.6 Terminal maintenance shafts**

*Terminal Maintenance Shafts are not acceptable in New Plymouth District. Terminal Maintenance Shafts are accepted in South Taranaki District.*

Where terminal maintenance shafts (TMSs) have been authorised by the TA and where it is expected that human access below ground will not be required, TMSs may be used on DN 150, DN 200, and DN 225 pipes as an alternative to MHs, providing the conditions detailed in this Standard are satisfied.

For construction details see Appendix B drawing WW – 003.

**5.3.8.6.1 Design parameters**

A TMS may only be used as a terminating structure under the following conditions:

- (a) At the permanent end of a wastewater pipe;
- (b) On DN 150, DN 200, and DN 225 pipes;
- (c) After the last MH (with no intermediate MS) provided it is spaced no further than 120 m from that MH, as shown in Figure 5.1;
- (d) After an intermediate MS, as shown in Figure 5.2;
- (e) Subject to the limiting conditions detailed in 5.3.8.5.1.

**5.3.8.6.2 Property connections into a permanent end**

TMSs may incorporate a maximum of two higher level property connection branches discharging directly into the riser shaft. Where a property connection is required directly ahead of the permanent end of the pipe (for example, a connection at the end of a no-exit road), a MS may be used instead of a TMS to accommodate the straight through connection. In such a case, a DN 100 connection will require a reducer immediately adjacent to the MS.

**5.3.9 Venting**

*Odour control measures will be required for:*

- (a) *All pumping stations,*
- (b) *Manholes where rising mains discharge into a gravity pipeline, and*
- (c) *Air valves situated within 50m of a property or habitable dwelling or within a residential area.*
- (d) *When the effluent is contained in the rising main for more than 6 hours.*

*In such situations vent shafts shall be installed as per the requirements of WSA 02 and WSA 04.*

### 5.3.10 Connections

Connections link private systems to the public system or other approved outlet point. Private systems extend through to the public system, except where the TA accepts responsibility for that part of the pipe outside private property.

#### 5.3.10.1 General considerations

The property connection should be designed to suit the existing situation and any future development. Each connection shall be capable of serving the entire building area of the property (unless specific approval is obtained from the TA).

*Sewer networks must be designed to ensure that the length of sewer laterals is the shortest possible distance, perpendicular to the sewer drain.*

#### 5.3.10.2 Requirements of design

The design shall specify the requirements for the property connections including:

- (a) Plan location and lot contours;
- (b) Invert level at property boundary or junction with the main as applicable

#### 5.3.10.3 Number of connections

It is normal practice to provide one connection per lot. Provision of additional connections shall be subject to justification by the developer and approval by the TA.

For multiple occupancies (unit title, cross lease, or company lease), service of the whole property is normally achieved by providing a single point of connection to a TA system. Connection of the individual units is by joint service pipes owned and maintained by the body corporate, tenants in common or the company as the case may require. In this instance the whole of the multiple occupancy shall be regarded as a single lot.

Alternatively, if authorised by the TA, developers have the option of providing wastewater facilities to the individual titles or tenements in new developments by:

- (a) Constructing individual connections which shall be owned and maintained by the body corporate, tenants in common or the company; or
- (b) Extending the public line into the lot and providing a separate connection to each unit *where approved by the TA.*

#### 5.3.10.4 Location of connection

The connection shall be located to service the lowest practical point on the property and where possible:

- (a) Be clear of obstructions, such as trees, tree roots, paved areas;
- (b) Be easily accessible for future maintenance;
- (c) Be clear of any known future developments, such as swimming pools or driveways;
- (d) Avoid unnecessarily deep excavation >1.5 m where practicable;
- (e) Be within or on the property boundary;
- (f) *Sewer networks must be designed to ensure that the length of sewer laterals is the shortest possible distance, perpendicular to the sewer drain.*

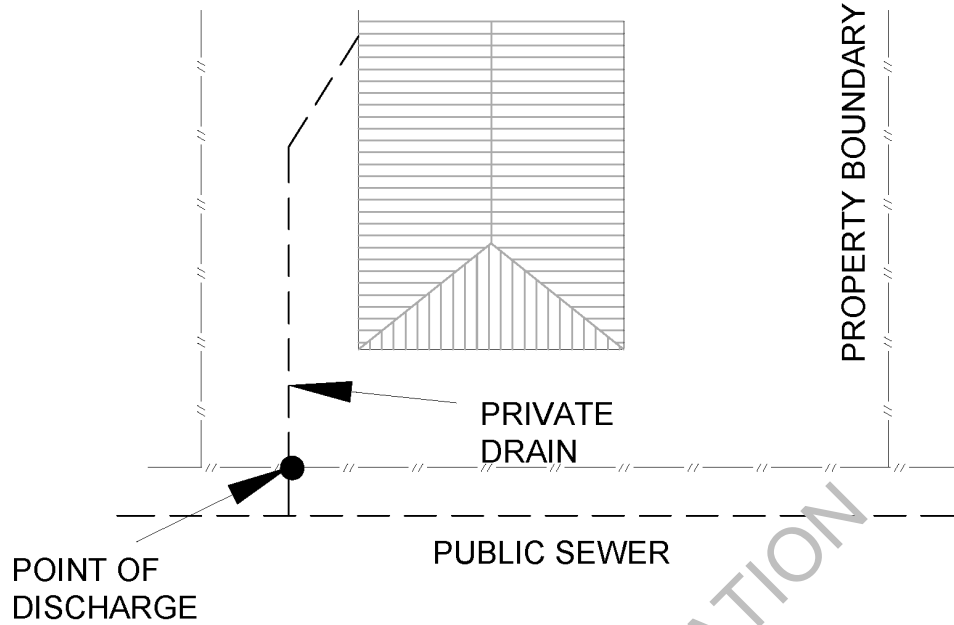

Figure 5.3 - Point of discharge location - single dwelling with street frontage (NPDC only)

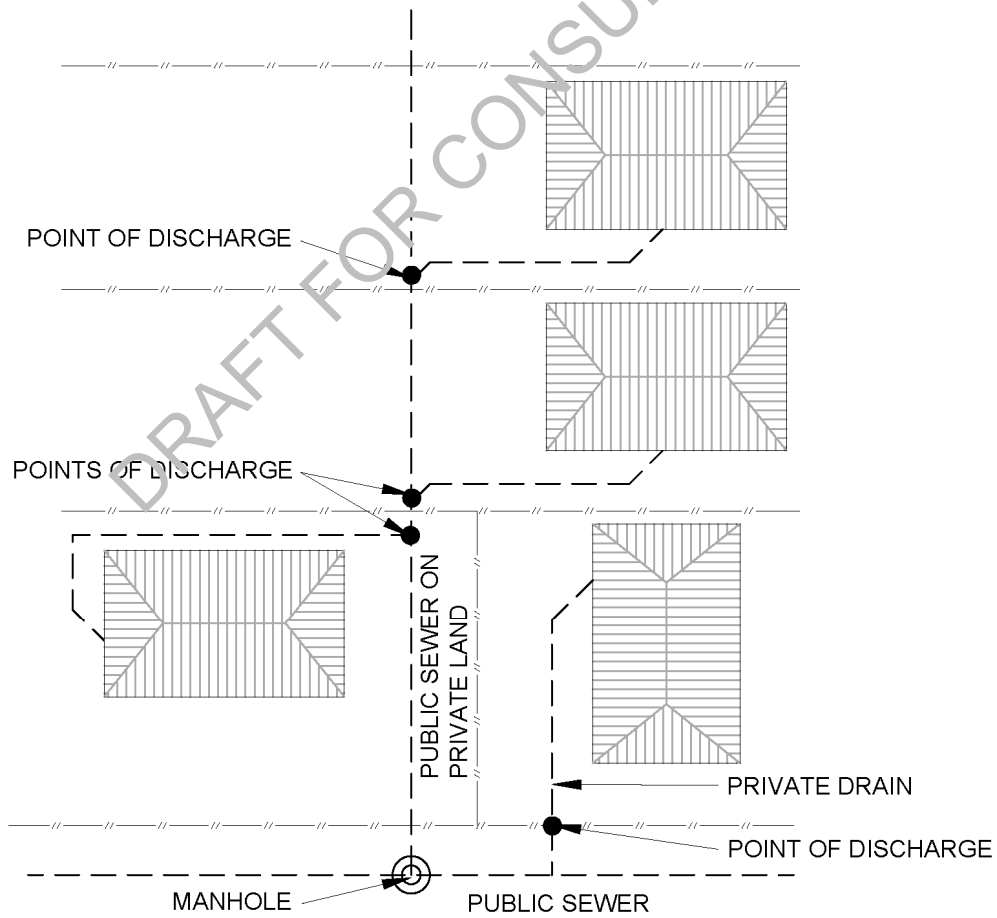

Figure 5.4 - Point of discharge location - sewer on private land

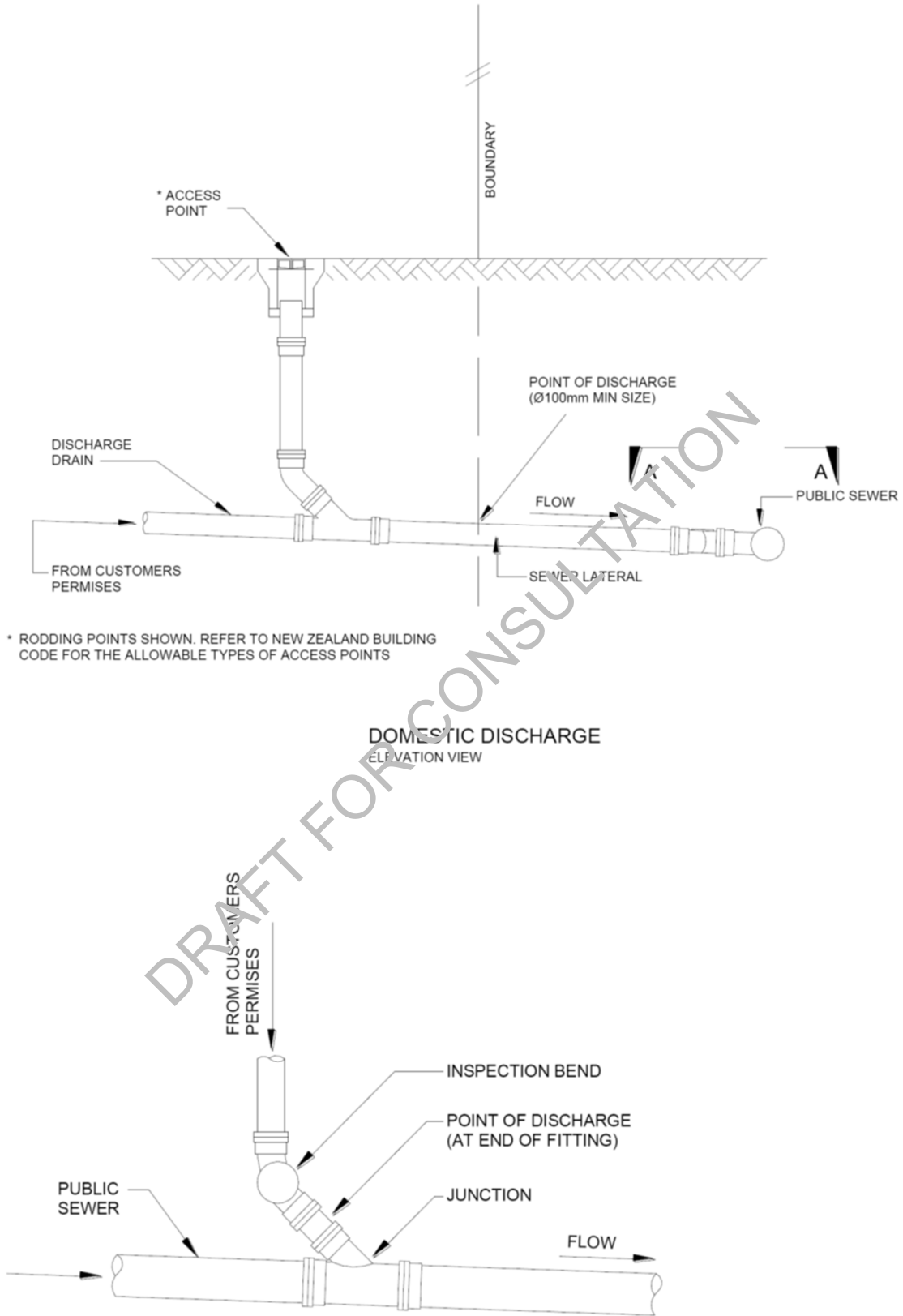

Figure 5.4a - Typical layout at point of discharge (STDC only)

**5.3.10.5 Connection depth**

Connection depths shall be set to drain the whole serviced area recognising the following factors:

- (a) Surface level at plumbing fixtures of buildings (existing or proposed);
- (b) Depth to invert of pipe at plumbing fixture or intermediate points;
- (c) Minimum depth of cover over connection for mechanical protection;
- (d) Invert of public main at junction point;
- (e) Allowance for crossing other services (for clearances see Table 5.6);
- (f) Provision for basements;
- (g) Allowance for head loss in traps and fittings;
- (h) Allowance for any soffit depth set by the TA.
- (i) *Service connections shall be located such that each property is able to be serviced by gravity from ground level when the private sewer drains are laid at a slope of 1.25%.*
- (j) *For vacant lots the connection shall terminate not less than 1m inside the boundary with a terminal inspection, plugged, watertight and marked with a painted white timber stake.*
- (k) *Ramped risers shall be used for laterals greater than 1.2m deep. They shall rise at an angle of 45° until a depth of 1.2m is reached.*
- (l) *For existing sewers greater than 3.0m deep, connections may be made to a manhole or high level sewer a manhole. Multiple connections can be made to the same manhole in this case.*

The designed invert level at the end of the connection shall be not higher than the lowest calculated level consistent with these factors.

**5.3.11 Pumping stations and pressure mains**

Pumping stations and pressure mains shall be designed and installed in accordance with the standards of the TA. If the TA has no applicable standards, then they shall be designed in accordance with WSA 04.

Surge analysis and protection against surge pressures will be also required for wastewater pump/pumping main system

**5.3.11.1 Small Private Pump Stations**

*The Council as the network utility operator will accept the discharge of wastewater from small private pumping stations, serving individual lots. All private pump connections shall incorporate either an access chamber or a boundary kit located within public road reserve as close as practicable to the legal boundary of the property serviced. The point of discharge shall be either the joint on the inlet to the access chamber or the joint on the upstream end of a boundary kit. Where practicable the pressure connection shall discharge into a manhole located on the public sewer main. The property owner is responsible for maintaining the pipe up to the point of discharge. The Council is responsible for maintaining the pipe from the point of discharge to the public sewer main. For the avoidance of doubt the access chamber or boundary kit shall be owned and maintained by the council.*

*The connection between point of discharge and sewer must be carried out by a Council approved connection contractor.*

*The schematic layout for a private pump station connection to the council's reticulation is shown in Figure 5.6.*

**NOTE**

*Where a private pumping facility is used to dispose of wastewater from the site, the certificate of title shall be subject to an encumbrance. The encumbrance shall state that a private pumping facility is to be used to dispose of sewage from the site.*

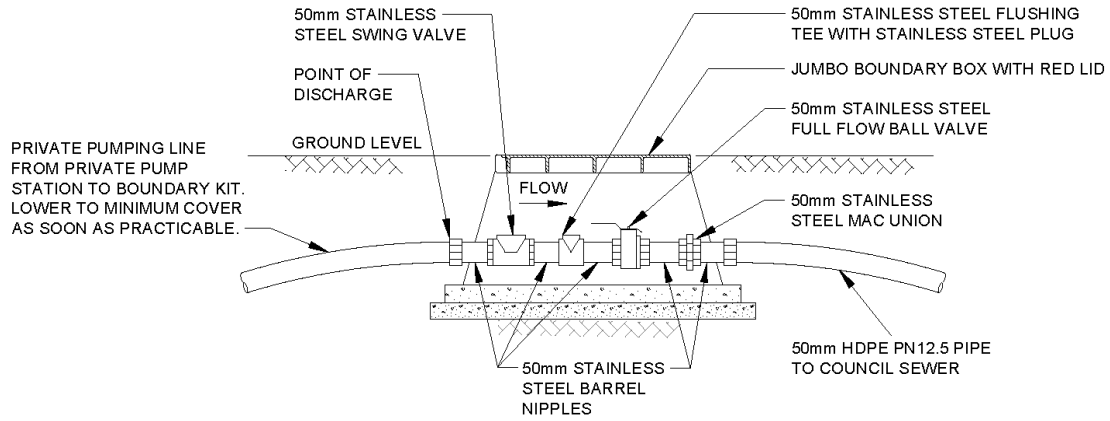

Figure 5.5 - Boundary kit detail

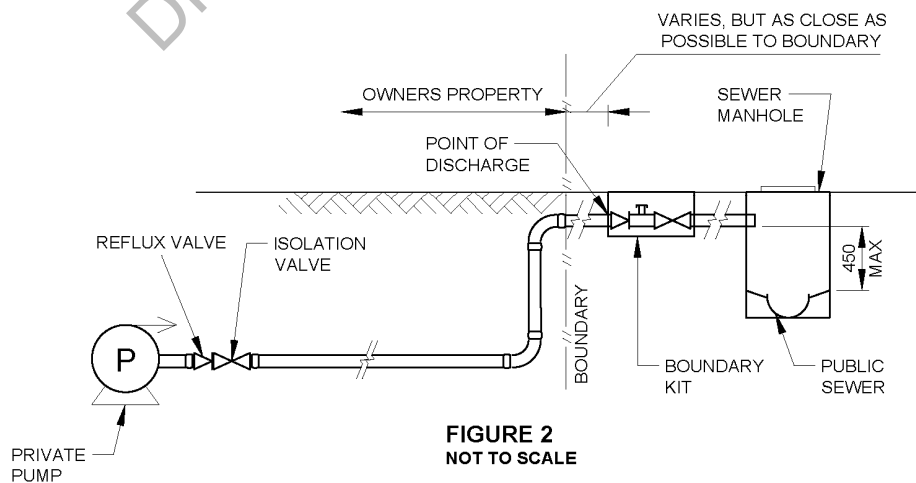
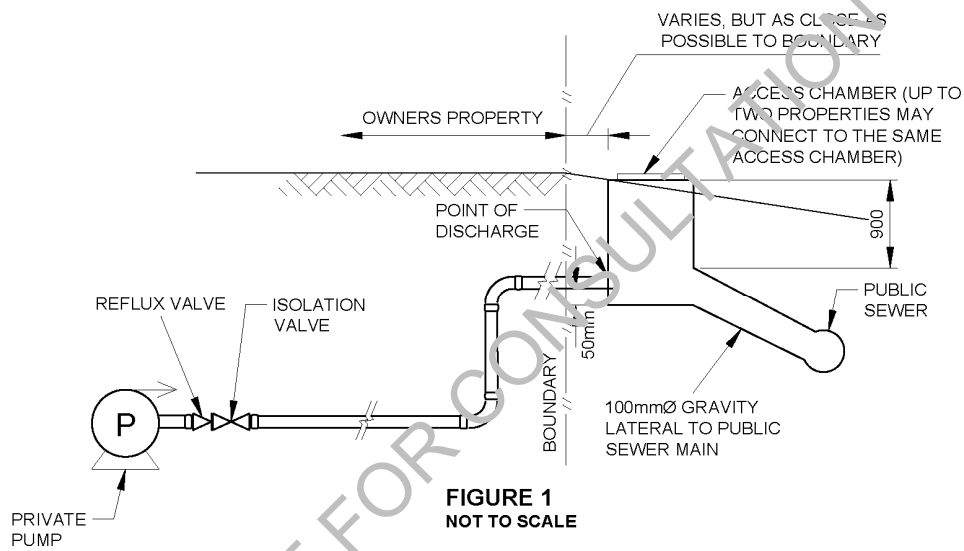
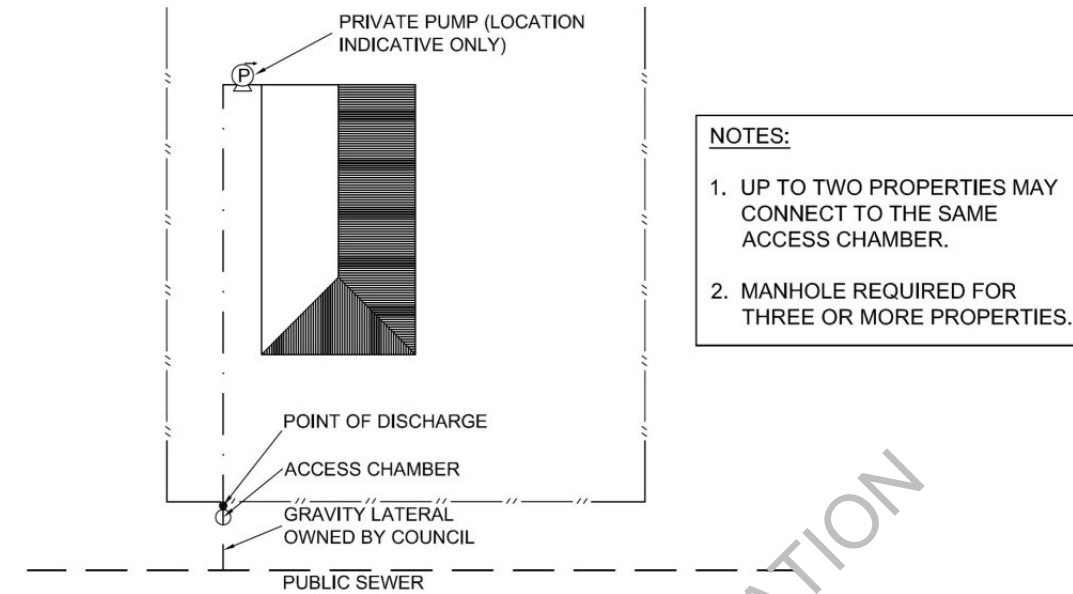
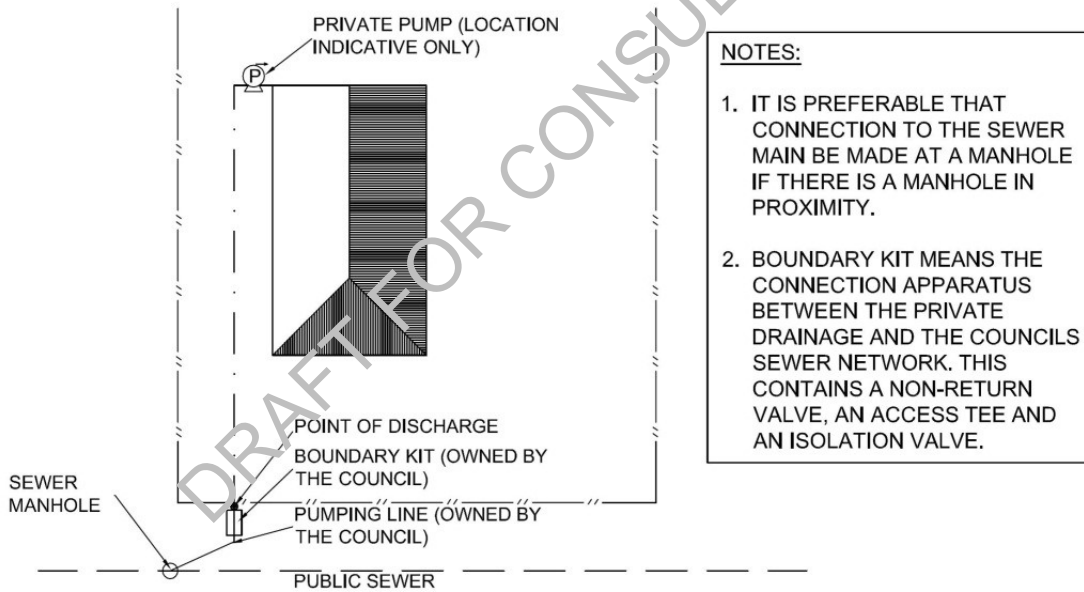

Figure 5.6 - Point of discharge locations - private pump stations (sections)





**PUMPING LINE TO GRAVITY LATERAL AT BOUNDARY**



**PUMPING LINE TO PUMPING LINE AT BOUNDARY**

Figure 5.7 - Point of discharge locations - private pump stations (plan)

**5.3.11.2 Small pump stations serving multiple properties**

To qualify for consideration as a public pump station, any development would need to demonstrate that more than 15 properties were unable to dispose of wastewater via gravity means.

Such pumping stations, where required, will be designed by the Council. The civil elements of the pumping station may be constructed by the developer, but all mechanical electrical and instrumentation installation and commissioning will be carried out by the Council. The developer shall bear the full cost of the design, construction and commissioning of the pumping station.

Pumping stations shall be sized to meet the level of service criteria of this design standard, including storage capacity to accommodate peak flows and an appropriate contingency volume in the event of a pump breakdown. All pumping stations shall include an overflow to an acceptable point of discharge, which may require resource consent from TRC.

Any pumping station shall be located on publicly owned land and positioned so that it is readily accessible by vehicle at any time of the day and in any weather conditions. It is expected that the pump station will include a hard surfaced access and a hard standing area. The pump station site will be fenced with a lockable gate.

The minimum pump station requirements are as follows:

- a) **Civil Requirements**
  - i) The pump station shall consist of one or more wet well chambers typically constructed from pre cast manhole chambers. Submersible pumps will be situated in one chamber along with control instruments. The chamber will be sized to provide a reasonable depth to suit pump control in normal and peak flow periods. The pumping station shall include a total emergency storage volume equivalent to 6 hours at design average dry weather flow from the fully developed upstream catchment connected to the pumping station. The pumping station shall include an emergency overflow above the level of emergency storage which discharges to an acceptable point. The overflow should be sized to convey design flow including diurnal and infiltration peaking factors.
  - ii) A separate manhole shall be provided immediately upstream of the pumping station. The volume of the manhole should not form part of the emergency storage. The manhole shall be capable of being isolated from the pumping station to allow a temporary pump to be used to bypass the pumping station wet well.
  - iii) A separate valve chamber will be provided for the pump discharge isolation and non return valves. A separate valved blanked branch will be included in the valve chamber to allow the pump station to be bypassed using a temporary pump. The valve chamber shall include a magflow meter positioned away from areas of turbulence as required by the manufacturer.
  - iv) Rising mains which are to be vested in the Council shall have a minimum internal diameter of 100mm. Any piping larger than an internal diameter of 100mm will require specific design with TA approval.
  - v) Electrical and control equipment will be sited above ground in a lockable building or kiosk.
  - vi) The building shall be constructed above ground and shall be suitably sized for the electrical control and instrumentation equipment.
  - vii) Clear access shall be provided for lifting equipment to allow lifting the pumps and equipment with a weight greater than 75kg.
  - viii) Installed lifting equipment shall be tested and the safe working load (SWL) displayed.
  - ix) Passive or fan forced ventilation shall be provided, and all vents shall be bird and vermin proof.
  - x) The pump station area shall have a uniform fall to drainage points located clear of walking areas and which prevent surface water entering the sewerage system.

- xi) *The layout shall take into account safe access that is free of trip hazards in the general access areas.*
  - xii) *The site will be provided with a min 3.5m wide concrete access and hard standing.*
  - xiii) *Fencing shall be provided to the pumping station site consisting of seven wire boundary fence with lockable gate as the minimum.*
- b) *Pumps*
- i) *Duty pump(s) to satisfy the flow and pressure requirements of the system.*
  - ii) *Standby pump(s) to provide back up for the duty pump(s) and cover demands up to 20% higher than the design maximum.*
  - iii) *Consideration shall be given to pump requirements during the developing stage of a network when the actual demand may be considerably lower than the design demand.*
- c) *Pipework and Valves*
- i) *All pipework including bends, tees, and welded threadlets shall be fabricated from Grade 316 stainless steel pipe of minimum wall thickness 1.5mm.*
  - ii) *A non return valve shall be installed on the discharge side of each pump.*
  - iii) *Appropriate valving shall be provided for bypassing the pump(s).*
  - iv) *The valve layout shall be designed to facilitate adequate isolation, support and removal of pumps and valves for maintenance purposes.*
- d) *All valves less than 100mm NB shall be stainless steel construction ball or gate valves.*
- e) *Electrical and Instrumentation*
- The electrical and control system shall include the following:*
- i) *Variable speed drives for each pump.*
  - ii) *Lockable control cabinet sufficiently sized for the electrical components.*
  - iii) *Adequate artificial lighting and light switch at the entry point.*
  - iv) *Separate ducting for control cables and power supply cables.*
  - v) *Magnetic flow meter located clear of flow disturbances, in accordance with manufacturer's requirements, and positioned so as to measure all flow through the pumping station whether through the pumps or bypass.*
  - vi) *Programmable Logic Controller control equipment and telemetry equipment as specified by the Council.*
  - vii) *Scada and telemetry equipment installed as required by the council*
- f) *Design and Operating Manuals*
- i) *Operation and Maintenance manuals - 3 copies shall be provided. The layout to be in accordance with the generic council plant operation and maintenance manuals.*
  - ii) *System design report including demand and pumping curves and commissioning procedures shall be included in the manuals.*

### **5.3.12 Pressure sewers and vacuum sewers**

Pressure sewers shall be designed and installed in accordance with the standards of the TA, with consideration in the design for cyclic dynamic stresses. Refer to the PIPA design guidelines (<http://www.pipa.com.au>). If the TA has no applicable standards, then they shall be designed in accordance with WSA 02 and WSA 07.

Vacuum sewers shall be designed and installed in accordance with the standards of the TA. If the TA has no applicable standards, then they shall be designed in accordance with WSA 06.

### **5.3.13 On-site wastewater treatment and disposal**

On-site wastewater treatment and disposal shall be designed and installed in accordance with the standards of the TA. If the TA has no applicable standards, then they shall be designed in accordance with AS/NZS 1546.1 and AS/NZS 1547.

*If the developments propose the use of septic tanks or on-site waste disposal, the Council may request a geotech report on soil investigation prior to any building consents. Provision of such reports or test results can be requested any time, including resource consent, during the consent procedures and is not limited to only building consents.*

## **5.4 Approval of proposed infrastructure**

### **5.4.1 Approval process**

Wastewater infrastructure requires approval from the TA.

### **5.4.2 Information to be provided**

Applications for design approval shall include the information outlined in 5.8 of this Standard. In addition the following information shall be provided:

- (a) A plan showing the proposed location of existing and proposed wastewater infrastructure;
- (b) Detailed long sections showing the levels and grades of proposed wastewater pipelines in terms of datum;
- (c) Long sections shall include full details of pipe and manhole materials and sizes;
- (d) Details and calculations prepared which demonstrate that Council's levels of service will be maintained;
- (e) Details and calculations prepared which clearly indicate any impact on adjacent area or catchment that the proposed infrastructure may have; and
- (f) Appropriate operating manuals, pump information, and instructions for pump stations and pressure systems if proposed.

## **5.5 Construction**

### **5.5.1 Pipeline construction**

The construction of pipelines shall be carried out in accordance with the requirements of AS/NZS 2032 (PVC), AS/NZS 2033 (PE), AS/NZS 2566 Part 1 and 2 (all buried flexible pipelines), AS/NZS 3725 (concrete pipes), or AS 1741 or BS EN 295 (VC).

### **5.5.2 Trenching**

See Appendix B drawings CM – 001 and CM – 002 for guidance.

Where a pipeline is to be constructed through areas with unsuitable foundations such material shall be removed and replaced with other approved material or alternatively, other methods of construction shall be carried out to the approval of the TA to provide an adequate foundation and side support if required for the pipeline.

### **5.5.3 Reinstatement**

Areas where construction has taken place shall be reinstated to a condition as required by the TA.

### **5.5.4 Inspection and acceptance**

Pipeline inspection and recording by closed circuit television (CCTV) shall be carried out prior to acceptance by the TA.

CCTV inspections and deliverables shall be in accordance with *New Zealand pipe inspection manual* and the requirements of the TA.

### 5.5.5 Leakage testing of gravity pipelines

Before a new pipeline is connected to the existing system, a successful field test shall be completed. The test shall be carried out as specified in Appendix C.

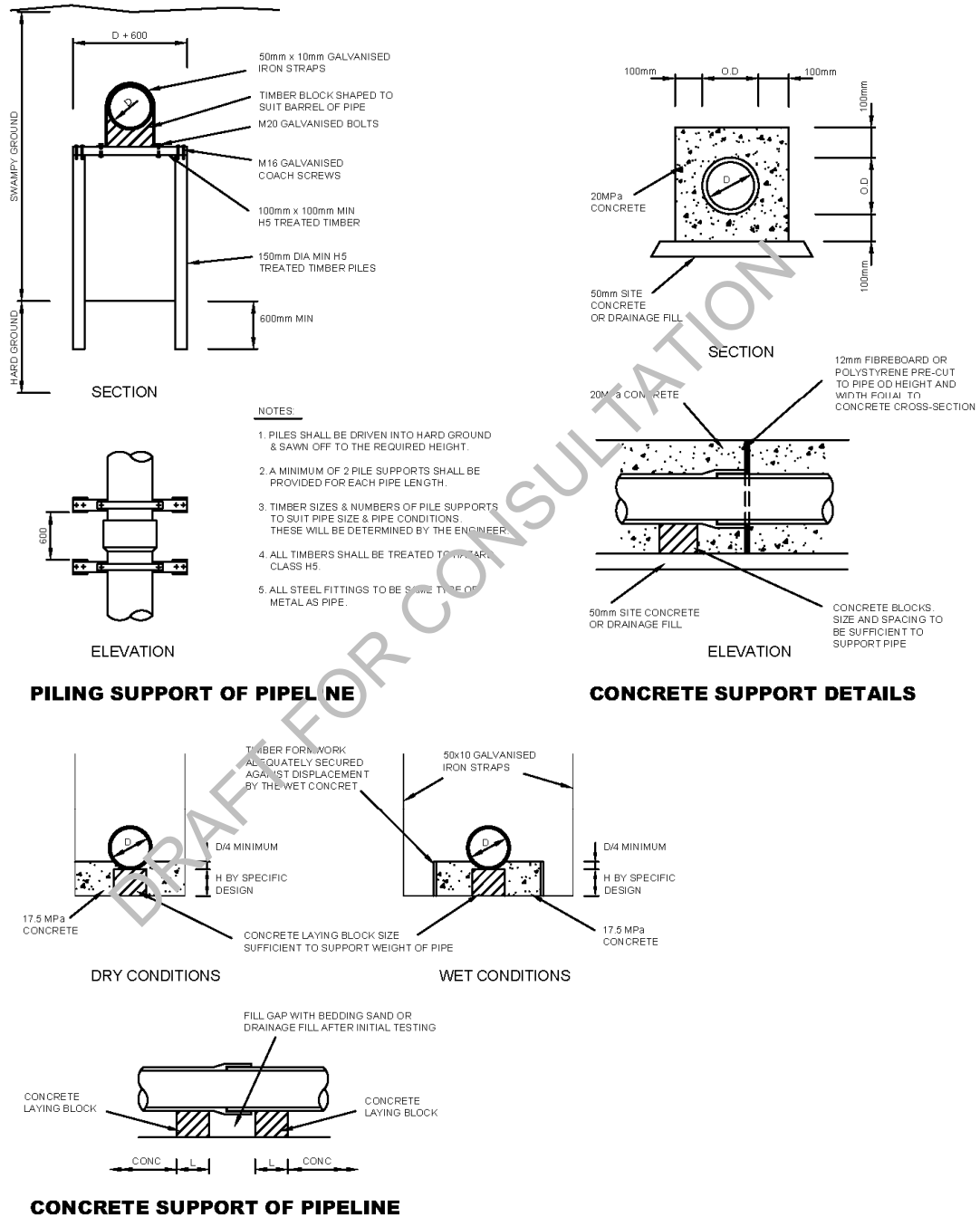

- NOTES –**
1. *Stainless steel pipework is required in New Plymouth District.*
  2. Refer to clause 6.3.8.10.

**Figure 5.8 - Pipeline support**

**5.5.6 Leakage testing of pressurised sewers**

Requirements for field testing of pressurised sewers are given in Appendix C.

**5.5.7 Manhole Testing**

*Requirements for field testing of manholes are given in Appendix C.*

DRAFT FOR CONSULTATION

## 6 WATER SUPPLY

### 6.1 Scope

This section sets out requirements for the design and construction of drinking water supply systems for land development and subdivision. It covers the design of both the localised reticulation system and the larger distribution network.

Water reticulation design is generally described in 'performance based' terms combined with 'deemed to comply' solutions. Individual TAs may specify additional or varying requirements. The designer is responsible for all aspects of the water system design, excepting those aspects nominated and provided to the designer by the TA.

If the scope of the development is large and includes its own water source, treatment or reservoirs, reference should be made to WSA 03.

Detailed plans and design calculations (where appropriate) shall be submitted to the TA. In addition the requirements outlined in section 1 of this Standard shall be met.

*All trunk mains, irrespective of size, shall be designed specifically and in close cooperation with TA.*

### 6.2 General requirements

#### 6.2.1 Objectives

The objectives are to ensure that the water reticulation system is functional, the required quality and quantity of water is supplied to all customers within the TA's designated water supply area, and the TA's requirements are satisfied.

*The design shall ensure an acceptable water supply for each property including fire flows by providing a service connection from the main to each property.*

*Where the existing reticulation or a proposed extension cannot comply with the minimum flow and pressure requirement, the applicant may be required to provide and install elevated storage and/or booster pumping systems to the approval of the Authorised Officer.*

The designer shall consider:

- (a) The TA's policies, customer charters, and contracts;
- (b) The hydraulic adequacy of the system;
- (c) The ability of the water system to maintain acceptable water quality;
- (d) The structural strength of water system components to resist applied loads;
- (e) The requirements of SNZ PAS 4509;
- (f) Environmental requirements;
- (g) The environmental and community impact of the works;
- (h) The 'fit-for-purpose' service life for the system;
- (i) Optimising the 'whole-of-life' cost; and
- (j) Each component's resistance to internal and external corrosion or degradation.

*An assessment and risk analysis shall be conducted to evaluate and address the impact of environmental and property damage in the event of a major water main failure.*

## 6.2.2 Referenced documents and relevant guidelines

Relevant legislation is listed in the Referenced Documents section of this Standard.

Water designs shall incorporate all the special requirements of the TA and shall be in accordance with the most appropriate Standards, codes, and guidelines including those set out in Referenced Documents, the Civil Defence Emergency Management Act 2002, and *Drinking-water standards for New Zealand 2005* (Revised 2008). Related Documents lists additional material that may be useful.

## 6.3 Design

### 6.3.1 Design life

All water supply systems shall be designed and constructed for an asset life of at least 100 years. Some components such as pumps, metering, control valves, and control equipment may require earlier renovation or replacement. Refer to WSA 03 for the classification of life expectancy for various components of water supply systems.

### 6.3.2 Structure plan

The TA may provide a structure plan setting out certain information to be used in design, such as flows, sizing, upstream controls, recommended pipe layout, or particular requirements of the TA. Where a structure plan is not provided, the designer shall determine this information by investigation using this Standard and engineering principles.

### 6.3.3 Future development

Where further subdivision, adjacent to the one under consideration, is provided for in the district or regional plan, the TA may require water supply infrastructure to cater for future development.

### 6.3.4 System design

Water mains shall be designed with sufficient capacity to cater for all existing and predicted development within the area to be served and to meet the requirements of SNZ PAS 4509.

The water demand allowance in the subdivision design shall include provision for:

- (a) Population targets;
- (b) The area to be serviced; or
- (c) Individual properties proposed by the developer.

Adjustment may be required to cater for the known performance (demand-based flows) of the existing parts of the water system.

### 6.3.5 Design criteria

#### 6.3.5.1 Hydraulic design

The diameter, material type(s), and class of the water main shall be selected to ensure that:

- (a) The main has sufficient capacity to meet peak demands while maintaining minimum pressure;
- (b) All consumers connected to the main receive at all times an adequate water supply and pressure; and
- (c) The appropriate firefighting flows and pressures can be achieved.

#### 6.3.5.2 Network analysis

Where required by the TA, a network analysis of the system shall be undertaken. The system shall be analysed using a mathematical model of the network to ensure adequate water supply is available to all consumers connected to the system for all defined modes of operation. The analysis shall include



all elements within the system and shall address all demand periods including peak demand, low demand flows, and fire flows.

### 6.3.5.3 Peak flows

Water demands vary on a regional basis depending on a variety of climatic conditions and consumer use patterns. The TA should be able to provide historically-based demand information appropriate for design. Where peak demands are required for the design of a distribution system, the value shall be calculated from the following formulae:

**Peak Day Demand (over a 12-month period) = Average Day Demand x PF**

Unless specified otherwise by the TA:

- (a) PF = 1.5 for populations over 10,000;
- (b) PF = 2 for populations below 2,000.

**Peak Hourly Demand = Average Hourly Demand (on peak day) x PF (over a 24-hour period)**

Unless specified otherwise by the TA:

- (a) PF = 2 for populations over 10,000;
- (b) PF = 5 for populations below 2,000.

### 6.3.5.4 Head losses

The head loss through pipe and fittings at the design flow rate shall be less than:

- (a) 5 m/km for DN ≤150;
- (b) 3 m/km for DN ≥200.

Head loss can be calculated using one of a number of standard hydraulic formulae. Some TAs have a preferred procedure and, where appropriate, this procedure should be used.

#### 6.3.5.4.1 Hydraulic roughness values

The hydraulic roughness values considered in the analysis shall take account of the pipe material proposed, all fittings and other secondary head losses, and the expected increase in roughness over the life of the pipe. The designer should check with the TA to ascertain if it has any requirements to use a specific formula and or roughness coefficients. If there are no specific requirements then it is recommended that the Colebrook-White formula is used (see Table 6.1). If the designer uses the Manning formula the coefficients in Table 6.1 are recommended.

**Table 6.1 Hydraulic roughness values**

Material	Colebrook-White coefficient k (mm)	Manning roughness coefficient (n)
PVC	0.003 – 0.015	0.008 – 0.009
PE	0.003 – 0.015	0.008 – 0.009
Ductile iron cement mortar lined	0.01 – 0.06	0.006 – 0.011
Mild steel cement mortar lined	0.01 – 0.06	0.006 – 0.011
GRP	0.003 – 0.015	0.008 – 0.009
NOTE – The values show a range of roughness coefficients. The lower value in the range represents the expected value for clean, new pipes laid straight. The higher value in the range represents the typical maximum expected for the product. It cannot be an absolute maximum, as the factors detailed in AS 2200 can lead to even higher roughness values in some circumstances. Recommendations on the appropriate roughness coefficient for a particular fluid may be obtained from the pipe supplier. Refer also to AS 2200 Table 2 and notes.		

**6.3.5.5 Minimum flows**

The minimum flow shall be the greater of:

- (a) 25 L/min for normal residential sites (20mm connection);
- (b) Fire flows as specified in SNZ PAS 4509.

The minimum flow for a restricted rural connection shall be 1,000 L/day.

**6.3.5.6 Minimum water demand**

- (a) Commercial and industrial flows

Industry type (water usage)	Design flow (litre/second/hectare)
Light	0.4
Medium	0.7
Heavy	1.3

- (b) Urban flows (flows in the urban supply area)

The minimum peak domestic demand shall be specified by the TA, or:

- (i) Daily consumption of 323 L/p/day;
- (ii) Peaking factor of up to 5.

- (c) Rural flows (flows in the rural supply area)

- (i) Daily consumption of 1000 L/lot/day;
- (ii) An additional flow of 500 L/ha/day;
- (iii) Peaking factor of 1.

- (d) Firefighting demands as specified in SNZ PAS 4509. See also 6.3.11.

- (e) The network should be designed to maintain appropriate nominated pressures for both peak demand (average daily demand in L/s x peaking factor) and firefighting demand scenarios. These figures should be applied to mains of 150 mm diameter or greater. Mains less than 150 mm in diameter can be sized using the multiple dwellings provisions of AS/NZS 3500.1 Table 3.2.

**6.3.5.7 Sizing of mains**

Tables 6.2 and 6.3 may be used as a guide for sizing mains.

**Table 6.2 Empirical guide for principal main sizing**

Nominal diameter of main DN	Capacity of main (single direction feed only)			
	Residential (lots)	Rural residential (lots)	General/light industrial (ha)	High usage industrial (ha)
150	160	125	23	–
200	400	290	52	10
225	550	370	66	18
250	650	470	84	24
300	1000	670	120	35
375	1600	1070	195	55

Notwithstanding Table 6.2, the water reticulation shall be designed to satisfy minimum flow and pressure requirements.

*DN 100 water mains may only be used in short right of ways in order to meet firefighting hydrant requirements, subject to TA approval.*

**Table 6.3 - Empirical guide for sizing rider mains**

DN 50 Rider mains		
Pressure	Maximum number of dwelling units	
	One end supply	Two end supply
High > 600 kPa	20	40
Medium 400 – 600 kPa	15	30
Low < 400 kPa	7	15

#### 6.3.5.8 Pressure zones

TAs may have maximum acceptable pressure requirements in any pressure zone. In some cases, a 'PRV zone' may be used to control the pressure delivered to an area. In these cases the designer shall consult with the TA to confirm pressure requirements.

#### 6.3.5.9 Maximum pressure requirements

An output of the hydraulic design of a pipeline is the specification of the maximum pressure that may be imposed on the pipeline during operation.

Inputs to the design process include:

- (a) Static head of supply;
- (b) The range of pressure and flows required to provide an acceptable level of service to the end-user (minimum pressure) and to avoid water leakage (maximum pressure).

The outputs of water main hydraulic design shall include:

- (c) Size of mains;
- (d) Maximum and minimum design pressure;
- (e) The pressure class/rating of pipeline system components;
- (f) Surge analysis results;
- (g) Hydraulic loss functions;
- (h) Specification of the maximum allowable operating pressure;
- (i) Flow and pressure compliance with peak demand and firefighting demand scenarios.

#### 6.3.5.10 Design pressure

The design pressures are the limiting pressures for operation of a pipeline system including any allowance for variation of usage in the future.

The minimum design pressure is either the minimum pressure defined by the TA or some higher pressure selected to control (minimise) the range of pressures experienced over the normal diurnal variation in the system.

A minimum pressure rating of each pipeline component is to be provided to the TA with the as-built details.

**Table 6.3a - Service pressure at point of supply**

	Urban	Rural
Maximum (static)		
New Plymouth	1200 kPa	
NPDC rest	1000 kPa	
Normal minimum (95 percentile on supply)	300 kPa	200 kPa

**6.3.5.10.1 Operating pressure/working pressure**

The operating pressure shall not exceed the rated pressure class/rating or the operating pressure limit of the pipeline components at that location.

**6.3.6 Water quality**

A number of factors in a network can adversely affect the quality of the water in the system. The network design shall ensure that the water quality at each property complies with the *Drinking-water standards for New Zealand 2005* (Revised 2008). The requirement to protect water supplies from the risk of backflow is stated in the Health (Drinking Water) Amendment Act s. 69(2Z) and this shall be adhered to.

**6.3.6.1 Materials**

All parts of the water supply system in contact with drinking water shall be designed using components and materials that comply with AS/NZS 4020.

*All materials used for construction shall be in accordance with the Schedule of Approved Materials contained in Appendix A.*

**6.3.6.2 Prevention of backflow**

Drinking water supply systems shall be designed and equipped to prevent backflow. The location and operation of hydrants, air valves, and scours shall ensure no external water enters the system through negative pressure from normal operation.

*Backflow prevention is required at the point of supply for all connections. Industrial and commercial water connections shall be a minimum of 'medium risk'. Residential water connections shall be a minimum of 'low risk non testable'.*

*The minimum allowable operating pressure under any conditions, including surge, shall not fall below 100kPa in the New Plymouth District only.*

**6.3.6.3 Water age**

Drinking water supply systems shall be designed to minimise water age to ensure no unacceptable deterioration of water quality. This shall include:

- Mains with dead ends should be avoided by the provision of linked mains or looped mains. Particular care shall be taken at the boundaries between supply zones where dead ends shall be minimised;
- Mains for short runs shall be reduced in size or looped, for example no-exit roads (see Figure 6.5);
- Provision of large diameter mains capacity shall be staged by the initial provision of a smaller main, followed by additional mains as the demand increases. Discussions should be held with the TA on staging, as multiple mains may not be desirable and larger mains with a scouring programme may be preferred instead.

**6.3.7 Flow velocities**

In practice it is desirable to avoid unduly high or low flow velocities. Pipelines shall be designed for flow velocities within the range of 0.5 to 2.0 m/s. In special circumstances, velocities of up to 3.0 m/s may be acceptable.

For pumping mains an economic appraisal may be required to determine the most economical diameter of pumping main to minimise the combined capital and discounted pumping cost. The resulting velocity will normally lie in the range 0.8 m/s to 3.0 m/s.

The following factors shall be considered in determining flow velocity:

- (a) Stagnation;
- (b) Turbidity (large fluctuations in flow rates can dislodge the biological slime or stir up settled solids in pipelines);
- (c) Pressure;
- (d) Surge;
- (e) Pumping facilities;
- (f) Pressure reducing devices;
- (g) Pipe lining materials.

#### 6.3.7.1 Surge analysis

A surge analysis shall be undertaken for any pipeline within a pumped system or system containing automated valves. The source of any significant pressure surges or high-pressure areas shall be identified and remedial measures to minimise pressure surges designed and specified.

### 6.3.8 System layout

#### 6.3.8.1 General

Water mains are *to be* located in the road. The location shall be specified by the TA, within the road or space allocation nominated by the road controlling authority. Where approved by the TA water mains may be located in private property or public reserve.

Water mains should:

- (a) Be aligned parallel to property boundaries;
- (b) Should not traverse steep gradients; and
- (c) Should be located to maintain adequate clearance from structures and other infrastructure.

#### 6.3.8.2 Reticulation layout

A principal water main of not less than nominal internal diameter (DN) 150, fitted with fire hydrants, shall be laid on one side of all public roads and no-exit roads in every residential development. A DN 50 rider main shall be laid along the road frontage of all lots not fronted by the principal main. A DN 50 rider main shall also be provided for service connections where the principal main is DN 250 or larger. The principal mains serving commercial and industrial areas shall be at least DN 150 laid on both sides of the road. This requirement may be relaxed in short no-exit roads as long as adequate firefighting coverage is available.

#### 6.3.8.3 Mains layout

In determining the general layout of mains, the following factors shall be considered:

- (a) Main location to allow easy access for repairs and maintenance;
- (b) Whether system security, maintenance of water quality, and ability to clean mains meet operational requirements;
- (c) Location of valves for shut-off areas and zone boundaries (see 6.3.14);
- (d) Avoidance of dead ends by use of looped mains or rider mains;
- (e) Provision of dual or alternate feeds to minimise service risk.

**6.3.8.4 Water mains in private property**

Water mains located within private property will require an appropriately sized and registered easement in accordance with the TA's requirements.

*Easements shall be provided in favour of the Council where any Council owned pipeline crosses private property, or to provide access over private property to the Council's assets, and around Council assets for the purposes of maintenance and operation.*

*Such easements shall be 3 metres wide in the case of pipelines or access, and shall provide at least 2 metres clearance around other Council assets e.g. manholes.*

*Where the pipes are laid to a depth of 2 metres or more, greater easement width may be required to facilitate maintenance.*

**C6.3.8.4**

*Water mains and associated assets shall be located in the road reserve where possible. Where this is not possible (all other options have been exhausted) alternative solutions will be approved at the TA's discretion.*

*In the specific case of water mains located in right of ways within the New Plymouth district:*

- *If there are four lots (excluding the lots bordering onto the road boundary) or less, separate connections must be provided for the lots with manifolds and meters at the road boundary.*
- *Lots bordering onto the road boundary must be provided with separate connections from the water main in the road with manifolds and meters outside the boundaries of these lots.*
- *Easements must be registered over the water connections in the right of way in favour of the properties they serve.*
- *Jumbo manifold boxes must be used if two or more connections are provided at the road boundary.*
- *Each manifold must be tagged with the relevant lot numbers (and street numbers if known, this must be added later once street numbers have been allocated).*
- *If the developer is concerned about the distance from the proposed dwelling to the manifold in the road then it is recommended that a separate isolation valve be installed for the water supply pipes to that lot closer to the proposed dwelling site. This will enable the householders to shut off their water supply without having to go to the manifold box at the road boundary to do so.*

*If, for site specific reasons (e.g. ensuring adequate pressure at a dwelling), the above can't be achieved then the TA will consider at its sole discretion the installation of a 63 OD main in a right of way and vestment of this in the Council. In this case an Easement in Gross must be provided.*

*If a fire hydrant is required to comply with the NZ Fire Service Firefighting Water Supplies Code of Practice then the Council will own the hydrant and the main up to the hydrant. In this case manifolds may be located in the right of way up to location of the fire hydrant.*

**6.3.8.5 Types of system configuration**

Network layouts shall be established in accordance with TA practice. Interconnected ring systems should be provided when feasible. Refer to WSA 03 for further information.

**6.3.8.6 Water mains near trees**

Locating water mains within the root zone of trees should be avoided if possible. Where this is not practicable, careful attention to pipe material selection is necessary to minimise risk of pipe failure due to root growth.

**6.3.8.7 Shared trenching**

Where shared trenching is approved by the TA and utility service owners, a detailed design shall be submitted for approval by those parties and shall include:

- (a) Relative location of services (horizontal and vertical) in the trench;
- (b) Clearances from other services;

- (c) Pipe support and trenchfill material specifications;
- (d) Embedment and trenchfill compactions;
- (e) Trench markings;
- (f) Services' location from property boundaries;
- (g) Any limitations on future maintenance; and
- (h) Special anchoring requirements, such as for bends and tees.

Where approved by the TA and utility service owners, shared trenching may also be used for property service connections.

#### **6.3.8.8 Rider mains and duplicate mains**

A rider main shall be laid along the road frontage of all lots not fronted by a principal main.

Duplicate mains are required to provide adequate fire protection in the following cases:

- (a) Arterial roads or roads with a central dividing island;
- (b) Roads with split elevation;
- (c) Roads with rail or tram lines;
- (d) Urban centres;
- (e) Parallel to large distribution mains that are not available for service connections;
- (f) Commercial and industrial areas nominated by the TA;
- (g) Where required by SNZ PAS 4509.

#### **6.3.8.9 Crossings**

Water main crossings of roads, railway lines and underground services shall, as far as practicable, be at right angles. Mains should be located and designed to minimise maintenance and crossing restoration. The TA may require extra mechanical protection for the pipes or different pipe materials to minimise the need for future maintenance. *Existing AC water mains are to be replaced (full length joint to joint) when being crossed during construction work on new developments.*

#### **6.3.8.10 Crossings of waterways or reserves**

All crossings of waterways or reserves shall be specific designs to suit the TA's requirement.

Crossings shall, as far as practicable, be at right angles to the waterway or reserve. Reference should be made to the TA to establish whether it prefers elevated crossings or below waterway invert crossings. When the pipeline is placed under the invert level of a waterway it may require mechanical protection by concrete encasement or steel or other acceptable pipe duct. Different pipeline materials may need to be used for the crossing.

##### ***Pipes over water courses***

*As far as practicable, pipes crossing water courses shall be located at a level at least 500mm above the predicted 1%AEP flood level. Water mains shall be located on the downstream side of an existing bridge. Above ground pipework shall be suitably protected.*

*The pipeline shall be wrapped where it exits the ground. Both the pipe and the wrapping system must be suitable for above ground applications.*

*Manually operated air valves shall be installed at high points on pipe crossings.*

*Specific designs may be required for major stream-crossing or for large diameter or multiple pipes.*

**Pipe bridges**

*Pipe bridges shall be designed for a 100 year design life, and shall be constructed from materials that do not require periodic painting. Suitable materials are appropriately treated timber or reinforced concrete. As a general principle hot dipped galvanised or painted steel pipe bridges will not be accepted. All fittings or fasteners shall be Grade 316 stainless steel.*

*Pipe bridges shall be designed and sited such that they are at least 500mm clear of the 1% AEP flood level for the particular waterway crossed. Where the water course is identified as being at risk from lahars, the bridge shall be sited so that it is at least 500mm clear of the estimated maximum lahar height.*

*Pipe bridges on trunk mains shall allow for safe pedestrian access and shall include lockable barriers to prevent unauthorised access.*

*Please refer to Figure 5.8 - Pipeline support for pipe bridge design.*

**6.3.8.11 Location marking of valves and hydrants**

*The location marking of valves and fire hydrants shall be in accordance with NZ PAS 4509, Appendix L and Appendix B Drawing WS006. Where there is kerbing, kerb markers shall be used. Marker posts shall only be used where there is no kerbing. The location of boundary boxes shall be indicated by a "T" cut into the kerb.*

DRAFT FOR CONSULTATION



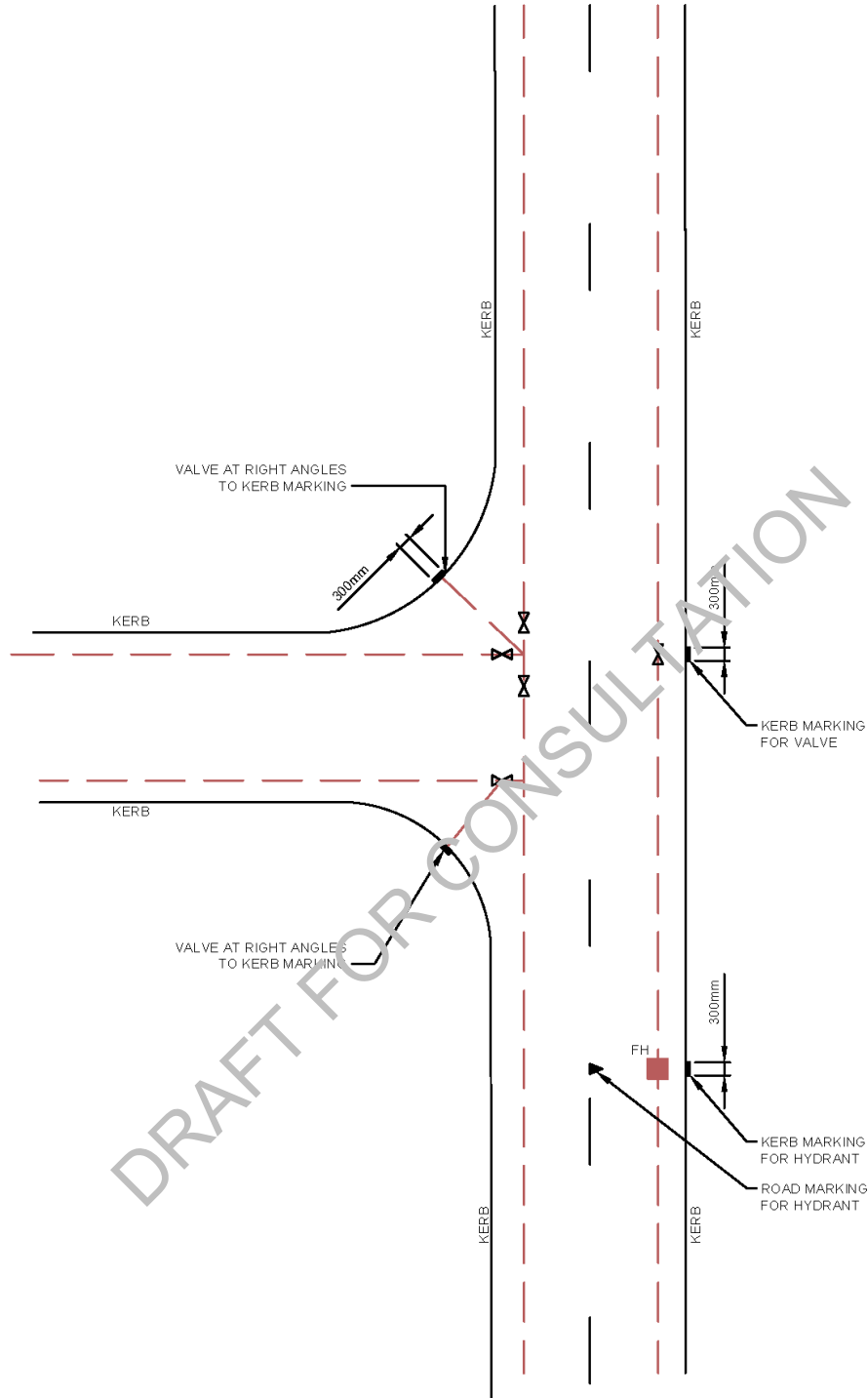

**NOTES –**

1. Kerb markings to be on face and top of kerb.
2. White kerb, white service box (STDC only).
3. "V" – kerb. Any valve that is normally intended to be closed (scour valve) – red (NPDC only).

**Figure 6.0 - Service markings**

### 6.3.9 Clearances

#### 6.3.9.1 Clearance from underground services

Where a pipe is designed in a road the location of the pipe from other services shall comply with the Code as defined in 8.2.2, unless the TA has its own requirements.

For normal trenching and trenchless technology installation, clearance from other service utility assets shall not be less than the minimum vertical and horizontal clearances shown in Table 6.4. Written agreement on reduced clearances and clearances for shared trenching shall be obtained from the TA and the relevant service owner prior to the commencement of construction.

**Table 6.4 - Clearances between water mains and underground services**

Utility (Existing service)	Minimum horizontal clearance (mm)		Minimum vertical clearance <sup>(1)</sup> (mm)
	New main size		
	DN ≤ 200	DN > 200	
Water mains DN > 375	600	600	500
Water mains DN ≤ 375	300 <sup>(2)</sup>	600	150
Gas mains	300 <sup>(2)</sup>	600	150
Telecommunications conduits and cables	300 <sup>(2)</sup>	600	150
Electricity conduits and cables	500	1000	225
Public mains	300 <sup>(2)</sup>	600	150 <sup>(3)</sup>
Wastewater pipes	1000/600 <sup>(4)</sup>	1000/600 <sup>(4)</sup>	500 <sup>(3)</sup>
Kerbs	150	600 <sup>(5)</sup>	150 (where possible)
NOTES – (1) Vertical clearances apply when water mains cross another utility service, except in the case of wastewater when a vertical separation shall always be maintained, even when the main and wastewater pipe are parallel. The main should always be located above the wastewater pipe to minimise the possibility of backflow contamination in the event of a main break. (2) Clearances can be further reduced to 150 mm for distances up to 2 m when passing installations such as poles, pits, and small structures, providing the structure is not destabilised in the process. (3) Water mains should always cross over wastewater and stormwater drains. (4) When the wastewater pipe is at the minimum vertical clearance below the water main (500 mm), maintain a minimum horizontal clearance of 1000 mm. This minimum horizontal clearance can be progressively reduced to 600 mm as the vertical clearance is increased to 750 mm. (5) Clearance from kerb and channel shall be measured from the nearest edge of the concrete. For water mains ≤ 375 clearances can be progressively reduced until the minimum of 150 mm is reached for mains DN ≤ 200. (6) Where a main crosses other services, it shall cross at an angle as near as possible to 90°.			

#### 6.3.9.2 Clearance from structures

Pipes adjacent to existing buildings and structures shall be located clear of the 'zone of influence' of the building foundations. If this is not possible, a specific design shall be undertaken to cover the following:

- (a) Protection of the pipeline;
- (b) Long term maintenance access for the pipeline; and
- (c) Protection of the existing structure or building.

The protection shall be specified by the designer for evaluation and acceptance by the TA.

Sufficient clearance for laying and access for maintenance is also required. Table 6.5 may be used as a guide for minimum clearances for mains laid in public streets.

*Structures must not be constructed over existing water mains.*

**Table 6.5 - Minimum clearance from structures**

Pipe diameter DN	Clearance to wall or building (mm)
<100	1500
100 – 150	1500
200 – 300	1500
375	2000
NOTE – These clearances should be increased for mains in private property (even with easements) as access is often more difficult and damage risk greater.	

#### 6.3.9.3 Clearance from high voltage transmission facilities

Water mains constructed from metallic materials shall generally not be located close to high voltage transmission lines and other facilities. Special design shall be undertaken if it is necessary to locate such mains close to such facilities.

#### 6.3.9.4 Deviation of mains around structures

Deviation of a pipeline around an obstruction can be achieved by deflection of the pipeline at joints, to the angular deflection limits stated by the pipe joint manufacturer and with suitably restrained fitting bends. Permitted angular deflection varies with pipe material, pipe wall thickness, pipe PN class, joint type, design and geometry. Some joint types are specifically designed to accommodate angular deflection. PVC and PE pipes may also be curved along the pipe barrel, between joints, to a minimum radius of curvature not less than that stated by the pipe manufacturer.

### 6.3.10 Pipe selection

The selection of the appropriate pipe material, sizes, and classes shall be based on system demands.

#### 6.3.10.1 Standard pipe sizes

The principal main shall be standardised as DN 150, 200, 250, 300, 375, 450, 525, 575, or 600 mm nominal diameter only. When larger pipes are required the exact diameter will be determined by the TA.

#### 6.3.10.2 Minimum pipe sizes

Minimum pipe diameters shall be as follows, where DN is the nominal pipe diameter:

- DN 50 for rider mains in residential zones;
- DN 100 for *right of ways* in residential zones *only*. Refer to Table 6.2;
- DN 150 for *residential*, industrial *and* commercial zones.

The TA may also specify minimum pipe diameters for other identified areas such as CBDs.

#### 6.3.10.3 Pipe PN class (pressure rating)

Pipe PN class is selected on the basis of the design pressure (head) calculated for the various sections of the reticulation network. This may be varied by specific operational requirements specified by the TA.

**6.3.10.3.1 Design pressure**

The design pressure (head) for the mains to be installed shall be based on the following:

$$\begin{aligned} \text{Design pressure, (m)} &= \text{Maximum Supply Pressure, (m above the level datum used} \\ &\quad \text{for the ground level)} \\ &+ \text{Surge Allowance, (m) (see 6.3.7.1)} \\ &- \text{Lowest Ground Level (GL) of the proposed main, (m above} \\ &\quad \text{datum)}. \end{aligned}$$

The design pressure (m head) shall be used for:

- (a) Selection of pipe materials and classes;
- (b) Selection of pipe fitting types and classes.

**6.3.10.3.2 Minimum pipe PN**

The minimum pipe and fittings PN to be used for water reticulation mains shall be *PN 12* (see Appendix A for list of pressure pipe and fittings standards). Designers shall verify the TA's minimum requirement before specifying the required pipe PN.

**6.3.10.3.3 Nominated pipe PN**

Some TAs may nominate a pipe PN (such as PN 12) for pressure pipes and fittings to standardise on a limited number of pipe PNs, or to allow future operational flexibility within their system. Where this is the case, the design pressure used as the basis for system design, anchorage, and pressure testing shall not exceed the TA's specified operating pressure limit associated with the pipe PN.

**6.3.10.3.4 Pumped mains**

For water mains in pumped systems, a detailed surge analysis shall be conducted unless otherwise directed by the TA to ensure:

- (a) The appropriate surge pressure is included in the calculated design head;
- (b) Surge control devices are included in the system design, where identified by the detailed analysis, to protect the network or control pressure fluctuations in the supply to customers, or both.

NOTE – Surge can also be managed by soft starts on pump motors, variable speed drives, and speed controls on valve closures, for example.

**6.3.10.4 Pipe materials**

For acceptable pipe materials and Standards see Appendix A.

**6.3.11 Fire flow**

*Water reticulation in all urban water supply areas is to be designed to provide water for firefighting.*

*The water reticulation in all residential zoned areas in the New Plymouth District shall be designed to comply with SNZ PAS 4509 to provide water for firefighting to FW2 at a minimum.*

*The water reticulation in all commercial and industrial zoned areas shall be designed to comply with SNZ PAS4509. However maximum firefighting water supply provided by the council network will be FW3.*

*The Council may require provision of fire fighting in rural areas.*

*Advice note: Non-reticulated areas are outside of scope of this document, however, the user's attention is drawn to the requirements of SNZ PAS 4509, in particular Table 2 in terms of water storage requirements for non-reticulated areas and Appendix B as a means of compliance.*

### 6.3.11.1 Fire protection services

Many commercial and industrial developments require installation of special fire protection services. While it is the responsibility of the site owner to provide these fire services, the developer shall design the water reticulation system to meet the required demands, where these are known in advance.

*Depending upon the nature of development the Council may require provision of fire hydrants irrespective of urban or rural designations.*

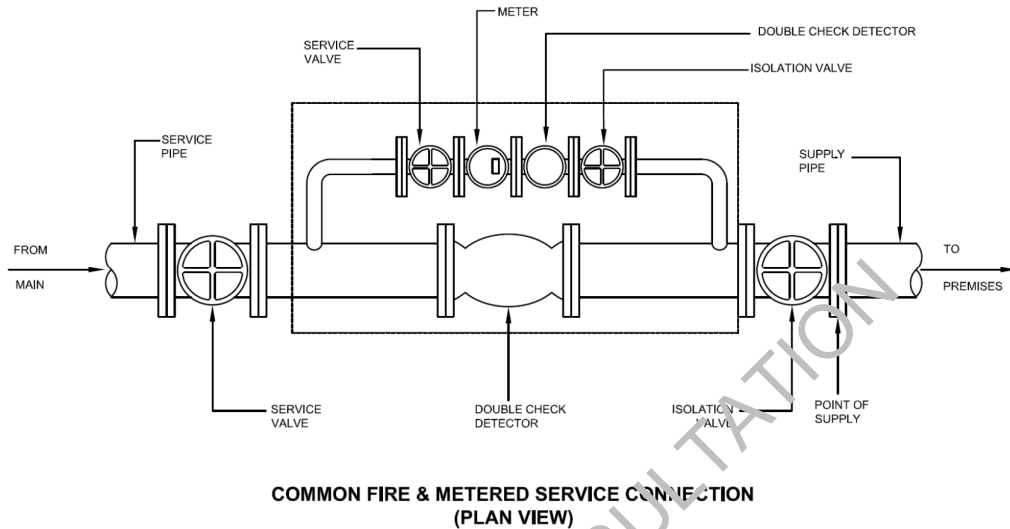

**Figure 6.0a - Fire and service connection details**

### 6.3.12 Structural design

#### 6.3.12.1 General

For installation conditions beyond those shown on the drawings, the pipeline installation shall be specifically designed to resist structural failure. The design shall be in accordance with AS/NZS 2566.1 including the structural design commentary AS/NZS 2566.1 Supplement 1. Details of the final design requirements shall be shown on the drawings.

#### 6.3.12.2 Seismic design

All pipes and structures shall be designed with adequate flexibility and special provisions to minimise risk of damage during earthquake. Historical experience in New Zealand earthquake events suggests that suitable pipe options, in seismically active areas, may include rubber ring joint PVC pipes, or PE pipes. Specially designed flexible joints shall be provided at all junctions between pipes and rigid structures (such as reservoirs, pump stations, bridges, and buildings) in natural or made ground.

#### 6.3.12.3 Structural consideration

Pipelines shall be designed to withstand all the forces and load combinations to which they may be exposed including internal forces, external forces, temperature effects, settlement, and combined stresses. The water main design shall include the selection of the pipeline material, the pipe class, and selection of appropriate bedding material to suit site conditions.

#### 6.3.12.4 Internal forces

Pipelines shall be designed for the range of expected pressures, including transient conditions (surge and fatigue) and maximum static head conditions. In the case of transient conditions the amplitude and frequency shall be estimated. The allowance for surge included in the maximum design pressure shall not be less than 200 kPa. Transfer and distribution mains subject to negative pressure shall be designed to withstand a transient pressure of at least 80 kPa below atmospheric pressure. A surge safety factor of 2 may be applied to the normal operating pressure to estimate the surge pressure in lieu of a detailed surge analysis.

**6.3.12.5 External forces**

The external forces to be taken into account shall include:

- (a) Trench fill loadings (vertical and horizontal forces due to earth loadings);
- (b) Surcharge;
- (c) Groundwater;
- (d) Dead weight of the pipe and the contained water;
- (e) Other forces arising during installation;
- (f) Traffic loads;
- (g) Temperature (expansion/contraction).

The consequences of external forces on local supports of pipelines shall also be considered.

**6.3.12.6 Geotechnical investigations**

The designer should take into account any geotechnical requirements determined under section 2 of this Standard.

Where required, standard special foundation conditions shall be referenced on the drawings.

**6.3.12.7 Pipe selection for special conditions**

Pipeline materials and jointing systems shall be selected and specified to ensure:

- (a) Structural adequacy considering ground conditions and water temperature;
- (b) Water quality considering lining material;
- (c) Compatibility with aggressive or contaminated ground;
- (d) Suitability for the geotechnical conditions;
- (e) Compliance with the TA's requirements.

**6.3.12.8 Above-ground water mains**

The design of above-ground water mains shall include the design of pipeline supports, maintenance and access requirements, control of unbalanced thrusts, and shall address exposure conditions, such as corrosion protection, UV protection, freezing of water mains, and temperature derating.

In such situations the pipe materials, support, and restraint for the pipes and fittings shall be detailed on the drawings.

**6.3.12.9 Trenchless technology**

Trenchless technology may be used as appropriate for alignments passing through or under:

- (a) Environmentally sensitive areas;
- (b) Built-up or congested areas to minimise disruption and reinstatement;
- (c) Railway and major road crossings;
- (d) Significant vegetation;
- (e) Vehicle crossings.

Pressure pipes used for trenchless installation shall have suitable mechanically restrained joints, specifically designed for trenchless application, which may include integral restraint seal systems, or heat fusion welded joints.

For information on trenchless installation methods see 5.3.6.8.

**C6.3.12.9**

Further information on trenchless technologies may be found in 'Trenchless technology for installation of cables and pipelines' (Stein), 'Trenchless technology – Pipeline and utility design, construction, and renewal' (Najafi), and 'Guidelines for horizontal directional drilling, pipe bursting, microtunnelling and pipe jacking' (Australasian Society for Trenchless Technology).

**6.3.12.10 Embedment****6.3.12.10.1 Minimum pipe cover**

Minimum cover to pipe shall be in accordance with manufacturer's recommendations, but not less than shown in Table 6.5a unless approved by the TA.

**Table 6.5a - Minimum cover**

	<b>Non trafficable - Road Berms, Reserves and Grassed Areas (including private property)</b>	<b>Trafficable - Carriageway (including shoulders)</b>
Water rider mains	600mm	600mm
Water service mains	750mm	900mm
Water trunk mains	900mm	900mm

The sections of pipe adjacent to a carriageway crossing shall be gradually deepened to allow the required cover under the carriageway without the provision of vertical bends. Similar provision shall be made to give the necessary cover over valve and hydrant spindles.

**6.3.12.10.2 Minimum trench width**

Pipe trench width design considerations shall be based on the minimum side clearances detailed in Appendix B drawing CM – 001 and shall comply with the pipe manufacturer's recommendations.

**6.3.12.10.3 Maximum Cover**

Maximum depths to the top of water mains shall be 1200mm, unless otherwise approved by the Authorised Officer.

**6.3.12.11 Pipeline restraint**

Anchorage shall be provided at bends, tees, reducers, valves, and dead ends where necessary.

**C6.3.12.11**

In-line valves, especially those DN 100 or larger, should be anchored to ensure stability under operational conditions. See Appendix B drawings WS – 001, WS – 002, WS – 003, WS – 004, and WS – 005.

**6.3.12.11.1 Thrust blocks**

The design of thrust blocks shall be based on the maximum test pressure.

Thrust blocks shall be designed to resist the total unbalanced thrust and transmit all load to the adjacent ground. Calculation of the unbalanced thrust shall be based on the maximum design pressure, or as otherwise specified by the TA.

Restraint joint systems, specifically designed to resist the total unbalanced thrust, and support all thrust load, may be used, instead of thrust blocks. These may include mechanical restraint coupling joints, or integral restraint seal systems.

Typical contact areas for selected soil conditions and pipe sizes are shown in Appendix B drawings WS – 004 and WS – 005.

Thrust blocks for temporary infrastructure shall be designed to the requirements for permanent thrust blocks.

#### **6.3.12.11.2 Anchor blocks**

Anchor blocks are designed to prevent movement of pipe bends in a vertical direction. They consist of sufficient mass concrete to prevent pipe movement (see Appendix B drawing WS – 005).

#### **6.3.12.11.3 Restrained joint water mains**

Commercially available mechanically restrained jointing systems may be used to avoid the need for thrust and anchor blocks subject to the approval of the TA. However many TAs will still require the use of thrust and anchor blocks.

### **6.3.13 Reservoirs and pumping stations**

*The need for tanks, reservoirs and pump stations shall be discussed with the Council at an early stage and will be subject to specific design agreed in conjunction with the Council by a suitable qualified person. All tanks, reservoirs and pump stations shall be located in publicly owned land.*

*The following outlines the Council's general design requirements:*

#### **RESERVOIRS**

- a) *The design or service life of the reservoir shall be 100 years with minimum maintenance requirements during this period. Timber or ferro-cement tanks will not be accepted.*
- b) *Seismic loads and design criteria on all structures and components of the works shall generally be in accordance with NZS 4203 Part 4 and the NZ National Society of Earthquake Engineering Seismic Design of Storage Tanks, December 1986 with a seismic risk factor of 1.6 (Table C2.1, NZS 3106:1986). For concrete reservoirs the design shall be in accordance with NZS 3106, and for steel reservoirs in accordance with NZS/ANSI/API650 or NZS/BS2654 or AWWA D100 or equivalent.*
- c) *The requirement specified in the NZ National Society of Earthquake Engineering Seismic Design of Storage Tanks, December 1986, for the seismic sloshing of tank contents and the consequent requirement for freeboard and/or the effect of pressures on the roofs of reservoirs shall apply to the design of reservoirs.*
- d) *The reservoir shall be fully enclosed.*
- e) *External faces of the reservoir shall be fully exposed, that is no fill or backfill against the faces. An underfloor subsoil drainage system that matches the pattern of the construction joints of the reservoir floor shall be installed. The drainage system shall allow CCTV inspection of any part of the system.*
- f) *The top level inlet shall be positioned away from the outlet.*
- g) *The bottom level outlet shall include a device to prevent the formation of a vortex at the entrance to the outlet, and a provision for 15% of reservoir capacity to be retained as emergency storage even in the event that the inlet and outlet pipe are severed.*
- h) *The reservoir shall incorporate an overflow, the capacity of which exceeds the maximum possible inflow.*
- i) *The reservoir shall be designed with a combined scour/emergency storage outlet with separate scour and emergency outlet drain pipes.*
- j) *The floor of the reservoir shall have a fall of not less than 0.5% to the point of exit of the scour/emergency storage outlet.*
- k) *An Internal ladder without safety hoops shall be provided located adjacent to the inlet.*
- l) *A vermin-proof personnel access hatch with lockable cover shall be positioned directly above the ladder together with safety handrails on the roof of the reservoir between the hatch and the outer rim of the reservoir and safety harness attachment point for a fall arrest system on the*



*inside rim of the hatch opening. The hatch cover is to be lockable in both the open and closed positions.*

- m) *An external ladder shall be located to the reservoir access hatch or in any other position as agreed with the Principal. The ladder system shall be similar to the Söll Y Spar system which includes built in fall arrest capability. The ladder shall include lockable security covers which prevent unauthorised use of the ladder. In addition to the permanent access a fitting is to be provided in the centre of each reservoir roof to provide a fixed point to secure a safety line for fall arrest purposes to allow personnel to access the full area of the roof safely. All external access requirements shall conform to OSH working at height requirements whilst meeting NPDC site security guidelines.*
- n) *A vermin-proof emergency access hatch with lockable cover shall be provided above the area in which the outlet, overflow and scour outlet are located, sized to accommodate a personnel stretcher. The hatch cover is to be lockable in both the open and closed positions.*
- o) *A vermin-proof air vent shall be provided in the roof of the reservoir with venting capacity sufficient to provide for normal inflows and outflows of water to and from the reservoir, and outflow under emergency conditions resulting from a major failure of the outlet pipe or downstream falling main.*
- p) *All roof openings shall be positioned or designed to prevent ingress of rainwater to the reservoir under all conditions.*
- q) *All reservoirs shall include compact seismic isolation of external pipework from the reservoir structure.*
- r) *A drainage and discharge chamber shall be provided for stormwater, reservoir overflow and scour discharges with a capacity of not less than 5 cubic metres. The chamber shall be located at a level below the floor level of the reservoir. The outlet of the chamber is to be provided with an upstand extending a minimum of 300mm above the base of the chamber. A manually operated isolation valve shall be provided on the outlet drain from the chamber, located immediately adjacent to the chamber.*
- s) *Valve chambers shall be provided as follows.*
  - (i) *A chamber immediately adjacent to the reservoir shall contain seismic isolators and inlet, outlet, overflows and scour pipework.*
  - (ii) *Flow control valve chamber shall be located over inlet and outlet pipework and shall contain, where applicable, altitude valve, flow control valve, flow meters, bypass pipework, and pressure reducing valve, air valves, and isolation valves.*
  - (iii) *An emergency outlet valve chamber shall be provided containing the isolation valve at the end of the emergency outlet pipe.*
- t) *All systems shall have automatic operation and control with SCADA installed (as directed by the Council).*

#### **PUMPING STATIONS**

*Booster Pumping Stations, where required, will be designed by the council. The civil elements of the pumping station may be constructed by the developer, but all mechanical electrical and instrumentation installation and commissioning will be carried out by the Council. The developer shall bear the full cost of the design, construction and commissioning of the pumping station.*

*Pressure booster pump stations shall be sized to meet the level of service criteria of this design standard, including firefighting requirements for urban supplies. The pumps shall be designed to deliver the maximum flows with the pressures required, and provide adequate pressures at the time of low flows.*

*Any pumping station shall be positioned so that it is readily accessible by vehicle at any time of the day and in any weather conditions. It is expected that the pump station will include a hard surfaced access and a hard standing area. The pump Station site will be fenced with a lockable gate.*

*The minimum pump station requirements are as follows:*

*Civil Requirement*

- (a) The building shall be constructed above ground and shall be suitably sized for the pumping and electrical equipment and pipework.*
- (b) Clear access shall be provided for lifting equipment to allow lifting the pumps and equipment with a weight greater than 75kg. Exit points shall be large enough to permit the removal of an injured person on a stretcher.*
- (c) The building shall be of masonry block construction, unpainted but sealed. Doors shall be fabricated aluminium and fitted with secure locks compatible with the Council's standard key system.*
- (d) A hand basin and tap supplied from the delivery side of the pump shall be installed within the building.*
- (e) Installed lifting equipment shall be tested and the safe working load (SWL) displayed.*
- (f) Passive or fan forced ventilation shall be provided, and all vents shall be bird and vermin proof.*
- (g) The floor shall have a uniform fall to a drainage point located clear of walking areas.*
- (h) The layout shall take into account safe access that is free of trip hazards in the general access areas.*
- (i) A chamber shall be located outside the building to accommodate the magflow meter. The magflow chamber shall include cable ducts connected to the building and drainage to a suitable discharge point.*
- (j) The site will be provided with a min 3.5m wide concrete access and hard standing.*
- (k) Fencing shall be provided to the pumping station site consisting of 7 wire boundary fence with lockable gate as the minimum.*

*PUMPS*

- (a) Duty pump(s) to satisfy the flow and pressure requirements of the boosted system.*
- (b) Standby pump(s) to provide back up for the duty pump and cover demands up to 20% higher than the design maximum.*
- (c) A duty low flow pump may be required if the main pumps minimum flow is higher than the system low demand flow.*
- (d) Consideration shall be given to pump requirements during the developing stage of a network where the actual demand may be considerably lower than the design demand.*

*VALVES, PIPES AND FITTINGS*

- (a) The pump station pipework shall terminate in a flange connection not less than 250mm outside the building foundation or magflow chamber.*
- (b) All pipework including bends, tees, and welded threadlets shall be fabricated from Grade 316 stainless steel pipe of minimum wall thickness 1.5mm.*
- (c) A non return valve shall be installed on the discharge side of each pump.*
- (d) Appropriate valving shall be provided for bypassing the pump(s).*
- (e) The valve layout shall be designed to facilitate adequate isolation, support and removal of pumps and valves for maintenance purposes.*
- (f) All valves less than 100mm NB shall be stainless steel construction ball, butterfly or gate valves.*
- (g) Pressure gauges and threaded tee fittings with ball valves shall be installed at the suction and discharge manifolds of the pump station.*

**ELECTRICAL AND CONTROL**

The electrical and control system shall include the following:

- (a) Variable speed drives for each pump.
- (b) Lockable control cabinet sufficiently sized for the electrical components.
- (c) Adequate artificial lighting and light switch at the entry point.
- (d) Separate ducting for control cables and power supply cables.
- (e) Magnetic flow meter located clear of flow disturbances, in accordance with manufacturer's requirements, and positioned so as to measure all flow through the pumping station whether through the pumps or bypass.
- (f) Suction and discharge pressure transmitters.
- (g) Programmable Logic Controller control equipment and telemetry equipment as specified by the Council.
- (h) Scada and telemetry equipment installed as required by the Council.

**DESIGN AND OPERATING MANUALS**

- (a) Operation and Maintenance manuals - 3 copies shall be provided. The layout to be in accordance with the generic Council plant operation and maintenance manuals.
- (b) System design report including demand and pumping curves and commissioning procedures shall be included in the manuals.

**6.3.14 Valves**

**6.3.14.1 General**

Valves are used to:

- (a) Isolate reticulation mains from distribution mains;
- (b) Isolate smaller reticulation mains from larger reticulation mains;
- (c) Isolate planning zone boundaries, for example, industrial, residential, or commercial.

Valves shall be provided:

- (d) Each side of freeways, arterial roads, and railway and tram crossings;
- (e) Adjacent to street intersections (for ease of location);
- (f) In the roadway, clear of roadway, where possible.

Subject to these considerations, valve numbers shall be minimised.

The TA should be consulted to establish the local requirement for connection type (flange or socket), as well as any other issues such as valve anchoring requirements.

*Typical valve installation and extension spindle details are shown in Figures 6.0b and 6.0c.*

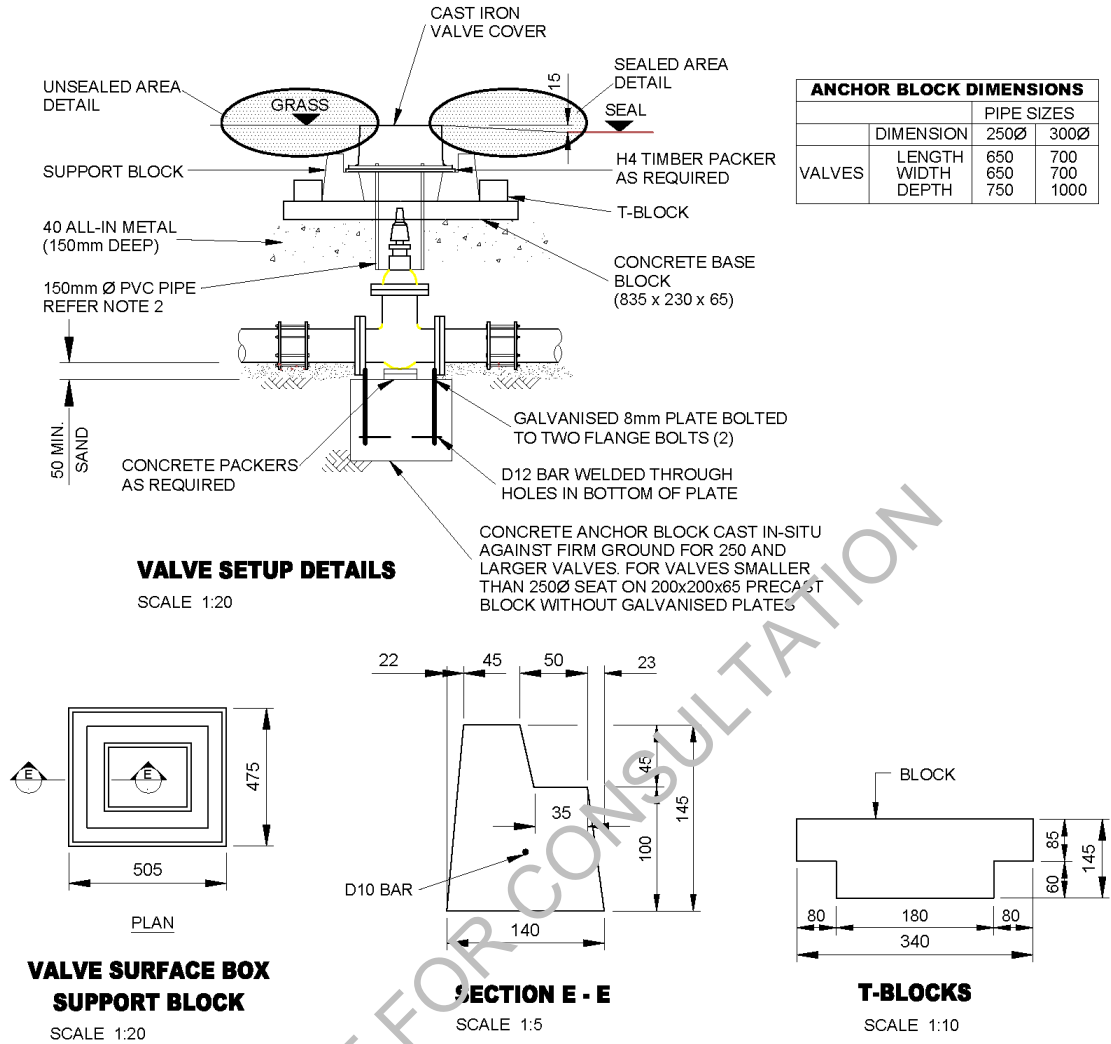

**NOTES –**

1. All concrete to be 20 MPa at 28 days.
2. Top of PVC riser pipe is to be clear of cast iron frame so that traffic loads are not.
3. Anchor block dimensions will vary according to valve size.

**Figure 6.0b - Valve installation details**

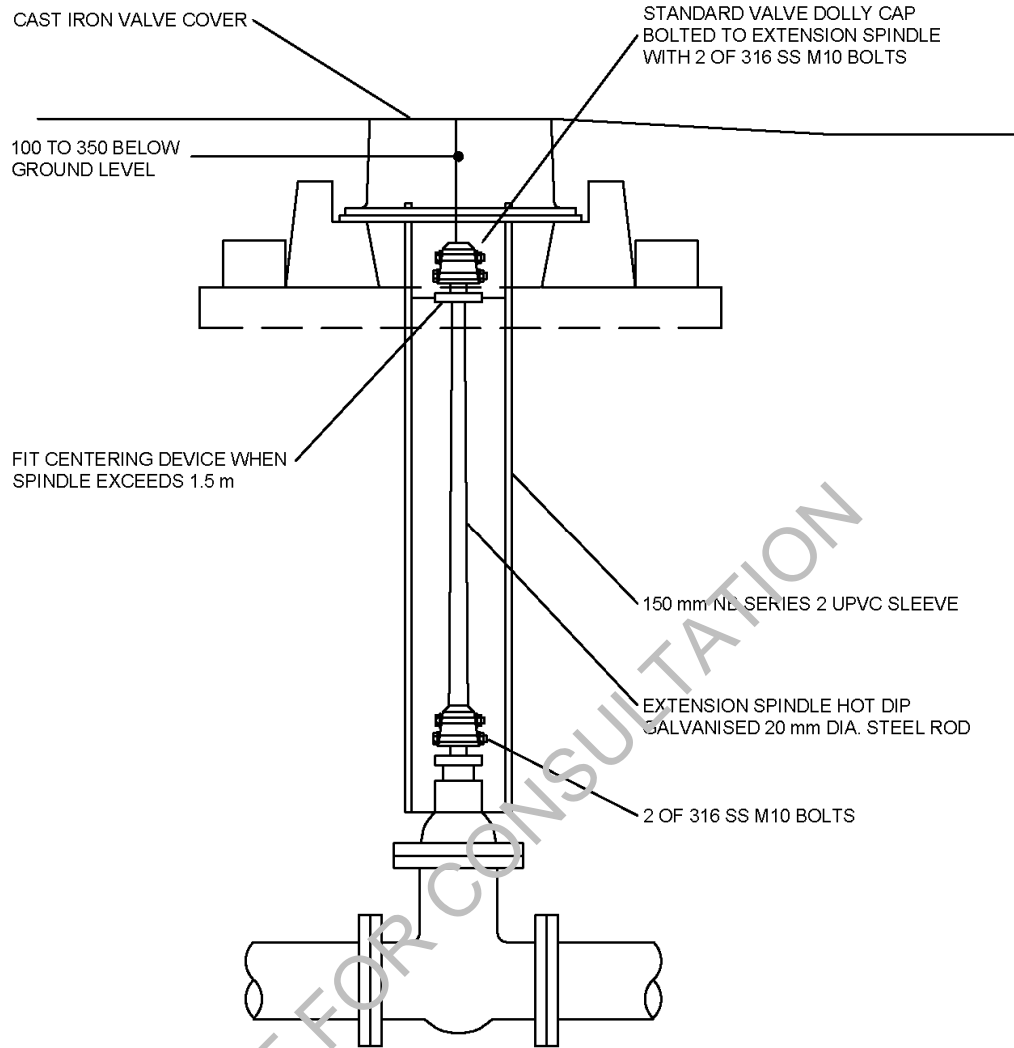

**Figure 6.0c - Valve extension spindle**

**6.3.14.2 Siting of valves**

The siting of valves shall take a holistic view of the existing infrastructure and proposed additions. General principles to be considered shall include:

- (a) Valves shall be sited to provide the control (such as flow, pressure, isolation, and diversion) required by the TA;
- (b) Ready access to valves to enable their safe operation. Account shall be taken of traffic and other site peculiarities;
- (c) Minimisation of inconvenience to the public by avoiding clustering of surface fittings in the footpath at intersections;
- (d) Optimisation of the number and location of valves to meet the TA's operation and maintenance requirements, safe working, and to minimise the effect of a shutdown on the TA's customers.

**6.3.14.3 Gate valves**

Valves shall have anti-clockwise rotation of the input spindle for closure, unless otherwise specified by the TA. Gate valves DN ≤ 50 (commonly called peet valves) shall be clockwise closing unless otherwise specified by the TA.

Buried gate valves shall be operated from above ground and shall be designed to facilitate the use of a standard key and bar. An extension spindle shall be incorporated as necessary to ensure the top of the spindle is 350 mm below the FSL.

Valves DN  $\geq$  80 shall be gate valves. In-line valves shall be the same diameter as the reticulation main.

#### **6.3.14.3.1 Gate valve spacing criteria**

*Isolation valves shall be installed in a logical pattern so that sections of the reticulation can be isolated to enable maintenance and repairs to be carried out on the isolated section while inconveniencing as few consumers as possible. To achieve this isolation valves shall be located:*

- *So that each section capable of being isolated serves no more than 20 consumers.*
- *So that rider mains can be completely isolated from distribution mains serving them.*
- *On three of the four legs leading from each cross connection.*
- *On two of the three legs leading from each tee intersection.*
- *So that the maximum distance between valves on water mains with services is not more than 300m.*
- *So the maximum distance between valves on water mains without services and including trunk mains is not more than 900m.*

**Table 6.6 – Deleted (Valve spacing criteria)**

#### **6.3.14.3.2 Branch mains**

*Stop valves shall be located on branch mains adjacent to the through water main. For all mains flanged tees and flanged valves shall be used (see Figure 6.1 and Appendix B drawings WS-001 and WS-002).*

*All joints between T and valve are to be restrained.*

Where a road crossing is necessary immediately after the tee branch and there is no space available adjacent to the tee, a stop valve shall be installed on the opposite side of the road (see Figure 6.1 and Appendix B drawings WS – 001 and WS – 002).

#### **6.3.14.3.3 Pressure zone dividing valves**

Pressure zone dividing valves and hydrants shall be installed in one of the following arrangements (see Figure 6.2):

- (a) Valves in a paired configuration with a standard fire hydrant located between them. Installation in this manner permits the valves to be checked for leakage. The valve on the low pressure side of the pair will normally be closed in order for the fire hydrant to be used for firefighting purposes with the supply from the higher pressure zone;
- (b) A valve with a standard fire hydrant on each side.

#### **6.3.14.3.4 Secure service connections**

Additional stop valves may be provided at a service connection to a customer requiring a greater security of supply such as hospitals and large industrial or commercial developments. Figure 6.3 illustrates typical arrangements to facilitate partial isolation of the main while maintaining supply to the customer.

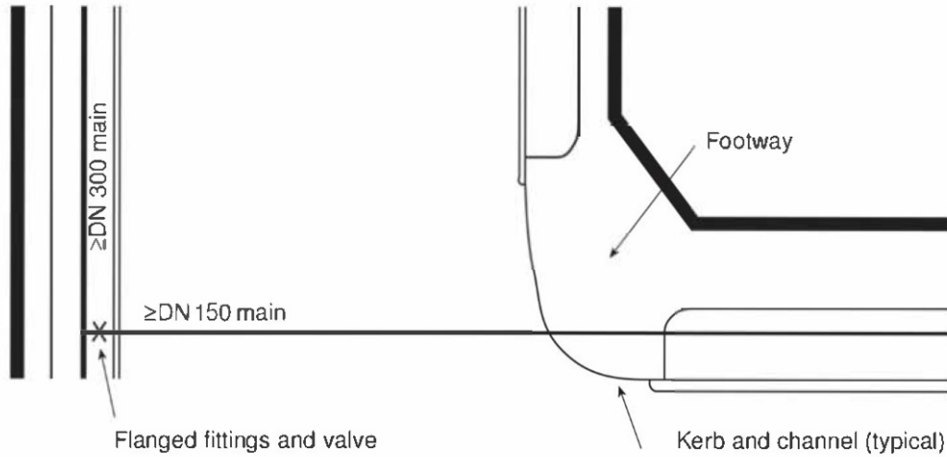

**Figure 6.1 - Branch valve adjacent to main**

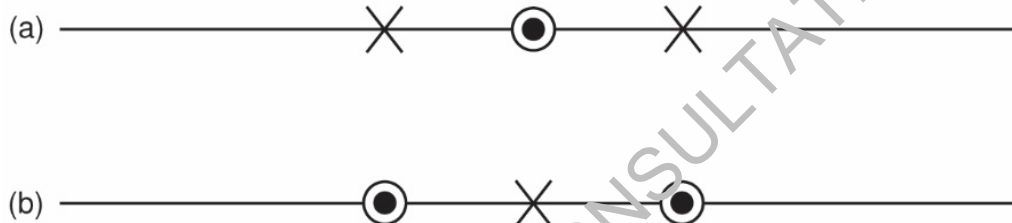

**Figure 6.2 - Valve and hydrant combinations for pressure zone dividing valves**

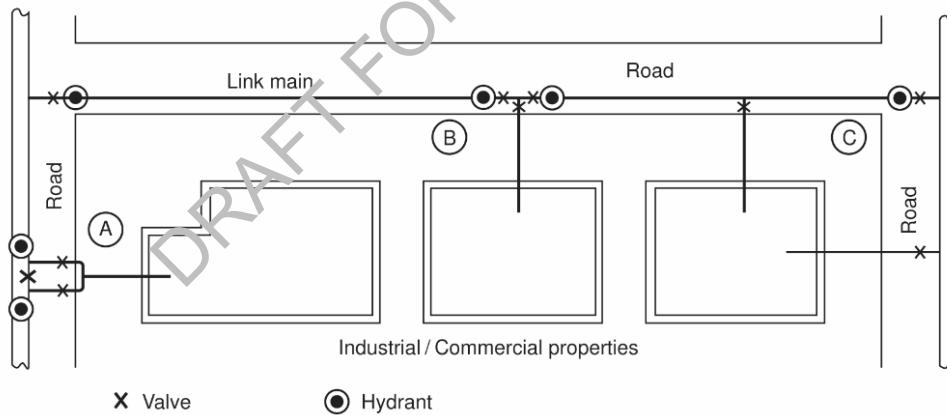

**Figure 6.3 - Secure connection**

**NOTES –**

1. Example A – feed from two directions off a large diameter water main. The arrangement is more complicated than Example B, but is justified by the cost of an additional large diameter stop valve which would be required if using Example B.
2. Example B – feed from two directions off a smaller diameter main. This is a simpler arrangement than Example A, but requires two valves on the main.
3. Example C – feed from two separate mains.

**6.3.14.4 Butterfly valves**

Butterfly valves shall only be used with the approval of the TA.

*C6.3.14.4*

*Butterfly valves are not normally used in reticulation mains as they hinder swabbing operations, and the quick closing action can induce high surge pressures.*

**6.3.14.5 Pressure reducing valves**

Where pressure reducing valves are required to maintain service pressures within the allowable range the location and type shall be approved by the Authorised Officer. The installation of a pressure reducing valve shall include a suitable flow metering device if required by the Authorised Officer.

*C6.3.14.5*

*A PRV is used to reduce the pressure upstream of the PRV to a desired lower downstream pressure. The PRV works automatically to maintain the desired downstream pressure. Refer to WSA 03 for design criteria.*

**6.3.14.6 Air valves**

Air valves shall be subject to specific design. Any requirement for air valves shall be discussed with the TA and shall only be incorporated with the approval of the TA.

**6.3.14.6.1 Installation design criteria**

Investigation into the need for air valves (AVs) shall be made for all high points on mains, particularly at points more than 2 m higher than the lower end of the section of water main and particularly if the main has a steep downward slope on the downstream side.

Where the hydraulic head is less than 10 m, special consideration shall be given to the type of AV to prevent water leakage from the valve. AVs shall be installed with an isolating valve to permit servicing or replacement without having to shut down the main.

Combination AVs, that is (dual) AVs incorporating an AV (large orifice) and an air release valve (small orifice) in a single unit, are generally the preferred type for distribution and transfer mains, and where required on reticulation mains.

The nominal size of the large orifice of air valves shall be DN 80 for installation on mains. This size has an exhaust capacity of approximately 0.3 m<sup>3</sup>/s.

*C6.3.14.6.1*

*Water mains with only a few service connections or a configuration that leads to air accumulation may require combination air valves to automatically remove accumulated air that may otherwise cause operational problems in the water system.*

*The configuration of the distribution network for both the change in elevation and the slope of the water main governs the number and location of air valves required.*

**6.3.14.6.2 Air valves location**

Air valves shall not be located in major roadways or in areas subject to flooding. When required, air valves shall be located:

- (a) At summits (high points);
- (b) At intervals of not more than 800 m on long horizontal, ascending, and descending sectors;
- (c) At every increase in downward slope;
- (d) At every reduction in upward slope;
- (e) On the downstream side of PRVs;
- (f) On the downhill side of major isolating valves;
- (g) At blank ends.



Where the air valve is in a valve chamber, the design shall ensure adequate venting for effective operation and drainage to prevent backflow contamination.

**6.3.14.7 Scours and pump-out branches**

Scours and pump-out branches are provided in the distribution network for maintenance purposes. They are designed to allow draining of water from the mains by gravity or use of a mobile pump.

*Hydrants may be used for scouring mains  $\leq$  DN150mm.*

**C6.3.14.7**  
*On mains DN  $\geq$  300, scours are more effective in draining and provide greater flushing velocities than hydrants.*

Scours and pump-out branches shall incorporate appropriate measures to prevent back siphonage into the water supply system.

There shall be adequate drainage facilities to receive the flow resulting from flushing and draining operations.

Scours shall:

- (a) Drain the water main by gravity or have provision for pump-out within a period of 1 hour, or both;
- (b) Have a diffuser fitted at the discharge point if there is a likelihood of environmental or asset damage; and
- (c) Not be subject to inundation.

**6.3.14.7.1 Scour sizes**

Scours shall be sized in accordance with Table 6.7.

**Table 6.7 - Minimum scour size**

Main Size (DN)	Scour Size (DN)
$DN \leq 100$	100
$DN > 150 - DN \leq 300$	150
$DN > 300$	As agreed with TA

**6.3.14.7.2 Scour locations**

Scours shall be located at:

- (a) Low points at the ends of water mains; and
- (b) Low points between in-line stop valves.

Scours shall drain to a point where the discharge is readily visible to prevent the scour valve inadvertently being left open.

Typical discharge locations include:

- (c) An approved pit that is to be pumped out each time the scour is operated (called a pump scour);
- (d) A kerb and channel;
- (e) An open-grated street drainage sump;
- (f) A natural water course (with energy dissipater).

Scours shall not:

- (g) Cause damage when operated;
- (h) Discharge to closed stormwater structures;
- (i) Discharge across roadways;
- (j) Discharge directly to waterways, unless in compliance with the appropriate consent requirements.

**6.3.14.8 Flushing points**

Flushing points shall be installed at the end of DN 50 rider mains (see Appendix B drawing WS – 002).

*Flushing points are required on all water mains and rider mains.*

**6.3.15 Hydrants**

**6.3.15.1 General**

Hydrants are installed on reticulation mains for firefighting or operational purposes. Operational purposes include mains flushing, chlorination, to allow the escape of air during charging, and the release of water during dewatering of the water main, where air valves and scours are not installed.

*Fire hydrants shall be installed as detailed in Figure 6.3a.*

**6.3.15.2 Hydrants for firefighting**

The spacing of hydrants for firefighting shall be in accordance with SNZ PAS 4509.

**6.3.15.3 Hydrant installation**

Fire hydrants shall not be fitted to reticulation mains DN <100 or to distribution or transfer mains without the prior written approval of the TA.

*Fire hydrants shall not be installed on rider mains.*

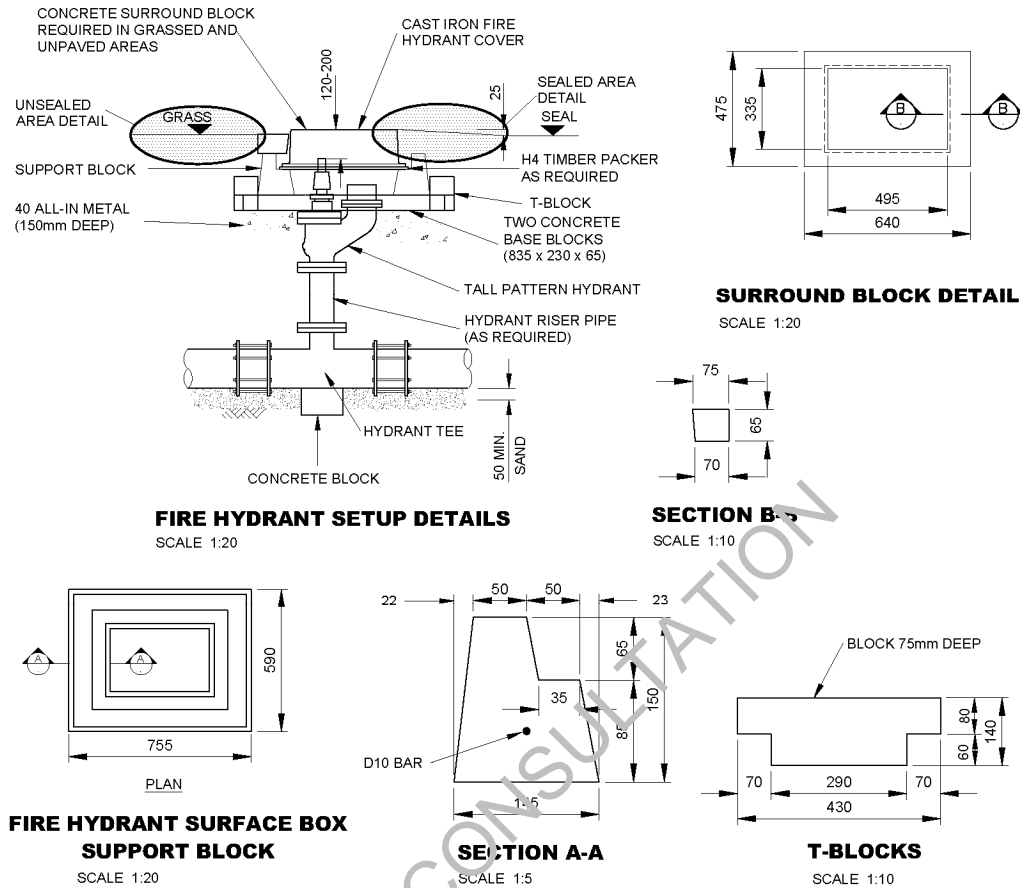

**NOTES –**

1. All concrete to be 20 MPa at 28 days
2. All fittings to be coated to AS/NZS 4158.
3. Gaskets to be 3mm neoprene.
4. All bolts to be 316 stainless steel or encapsulated.

**Figure 6.3a - Hydrant installation**

**6.3.15.4 Hydrants or reticulation system operational requirements**

Additional to firefighting requirements, hydrants shall be provided at:

- (a) High points on reticulation mains to release air during charging, to allow air to enter the main when dewatering, and for manual release of any build-up of air, as required, where automatic combination AVs are not installed;
- (b) Localised low points on water mains to drain the water main where scours are not installed.

Adequate drainage facilities shall be provided to receive the hydrant flows from dewatering and flushing operations.

**C6.3.15.4**

*AVs are not normally required on reticulation mains in residential areas where the configuration of mains and service connections will usually eliminate small amounts of air accumulated during operation; hydrants should be placed as close as possible to stop valves to facilitate maintenance activities such as cleaning of water mains.*

**6.3.15.5 Hydrants at ends of mains**

If a scour is not provided, a hydrant shall be installed as close as possible to the end of every main DN ≥ 100.

**C6.3.15.5**

*Apart from the firefighting function, a hydrant also allows the section of dead end main to be flushed regularly to ensure acceptable on-going water quality. This is particularly important in new subdivisions where only a small number of properties may be connected initially and where the main has been laid in a larger than required size with the expectation that it will be extended at a future date.*

**6.3.16 Connections****6.3.16.1 Connection of new mains to existing mains**

In specifying connection detail the designer shall consider:

- (a) Pipe materials, especially potential for corrosion;
- (b) Relative depth of mains;
- (c) Standard fittings;
- (d) Pipe restraint and anchorage;
- (e) Limitations on shutting down major mains to enable connections; and
- (f) Existing cathodic protection systems.

Connections from the end of an existing main shall be designed to address any differing requirements for the pipes being connected, particularly restraint, spigot/socket joint limitations, and corrosion protection. The designer shall consider the potential for insufficiently restrained/ anchored stop valves near the connection.

All connections to the existing reticulation shall be made by a contractor approved the TA.

**6.3.16.2 Property service connections**

Property service connections shall conform with the sizes permitted by the TA.

The method of connection (including tapping) is dependent on both the reticulation main and service connection pipe materials. The method adopted shall conform to:

- (a) Appendix B drawing WS – 003;
- (b) The requirements of the TA.
- (c) *Figure 6.3b Boundary Boxes.*

The position of the property connection toby valve, meter, and backflow device shall conform with the requirements of the TA. *All service connections shall include backflow prevention in accordance with the NZ Building Code Approved Document G12.*

*All connections shall incorporate a manifold assembly and the Council approved toby box with a blue lid cover.*

*Meters and a back flow preventer may be required at the Council's discretion.*

*All new water connections within New Plymouth and Stratford Districts require a water meter to be fitted to Council specification.*

*Service connections to households shall be in accordance with drawing WS-003 Amended and be a minimum of 20mm in diameter.*

*Connections to a principal main or rider main shall be with a tapping band.*

*Where possible boundary boxes shall be positioned outside the vehicle crossing, in order to facilitate maintenance.*

*Any material exceeding the standard service size needs to meet hydraulic requirements and be approved by the Council.*

**C6.3.16.2**

*In the case of residential infill development within New Plymouth and Stratford districts i.e. a subdivision where one house already has a connection and a new section(s) will be created adjacent to the existing section:*

- *New separate connections must be provided for the new section(s) and a meter(s) installed.*
- *If the existing connection has the old style toby then a new manifold must be installed as part of the development. However no meter is required for this section as the connection itself is not a new connection.*
- *If the existing connection already has the new manifold then no change is needed to this manifold and no meter is required as the connection itself is not a new connection.*

DRAFT FOR CONSULTATION

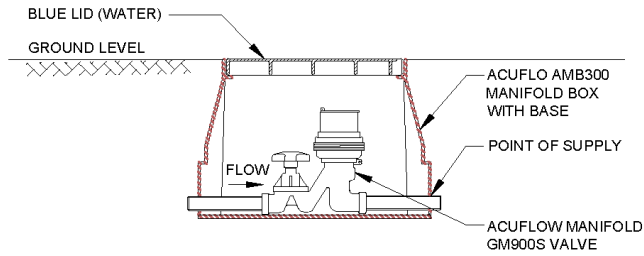

**BOUNDARY BOX DETAIL**

NOTE: STANDARD APPROVED MANIFOLDS AND BOXES TO BE USED

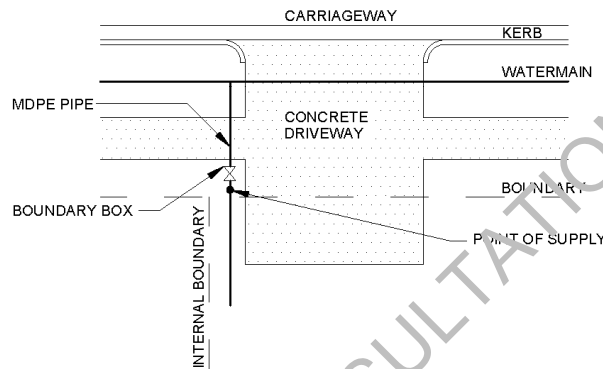

**SERVICE FOR SINGLE PROPERTY**

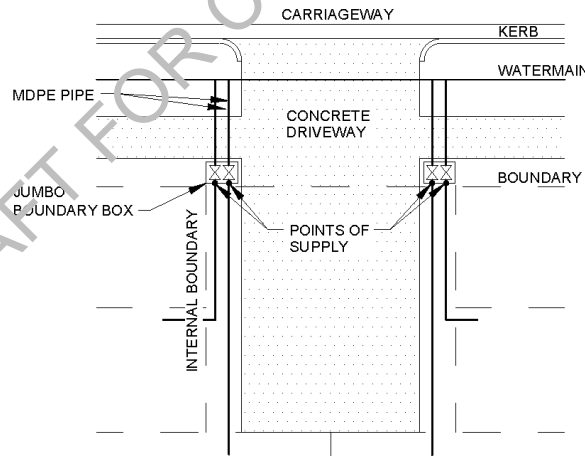

**SERVICE FOR RIGHT OF WAY**

**NOTES –**

1. The point of supply is the tail piece of the manifold, water meter, backflow preventer or service valve (toby), regardless of property boundary.
2. For cross lease units, each unit shall be installed with a separate service pipe from the council main. Where additional units are being built, additional points of supply will be required in such a position as to facilitate later subdivisions.

**Figure 6.3b - Standard water boundary box and point of supply (NPDC only)**

Refer to bylaws for SDC and STDC.

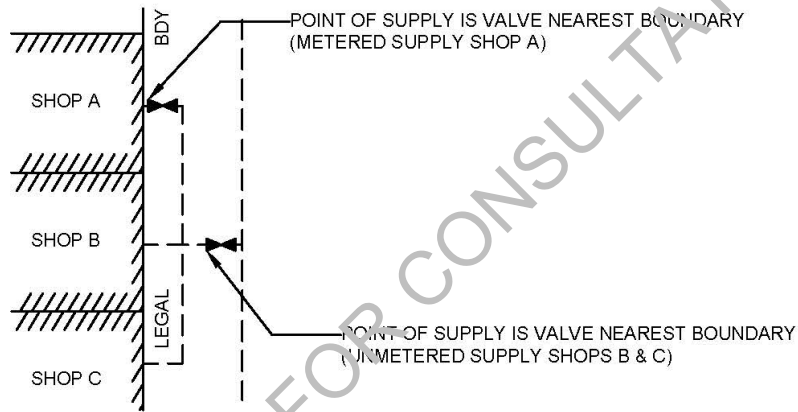
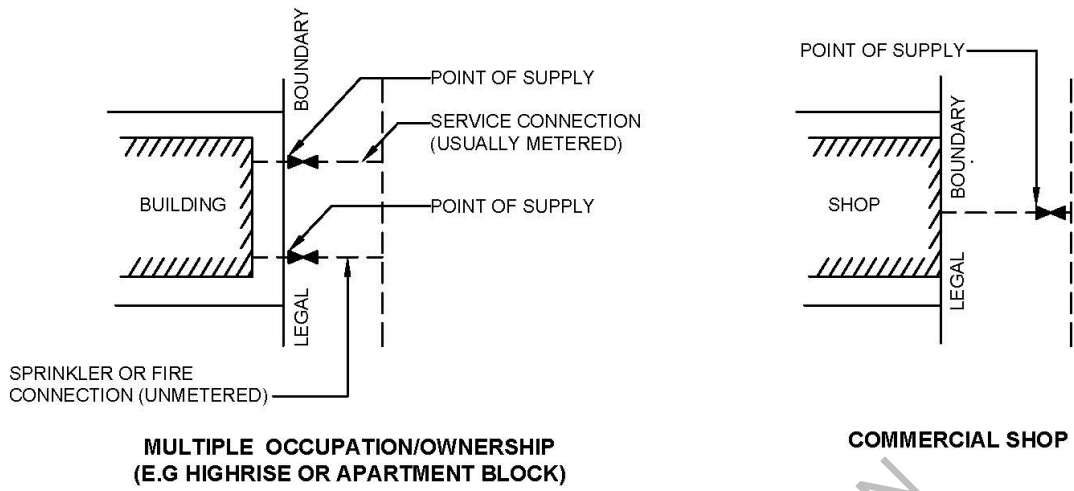

**NOTE –**

Point of supply is tail piece of boundary box, meter or service valve regardless of property boundary.

**Figure 6.3c - Point of supply for commercial connections (NPDC only)**

Refer to bylaws for SDC and STDC.

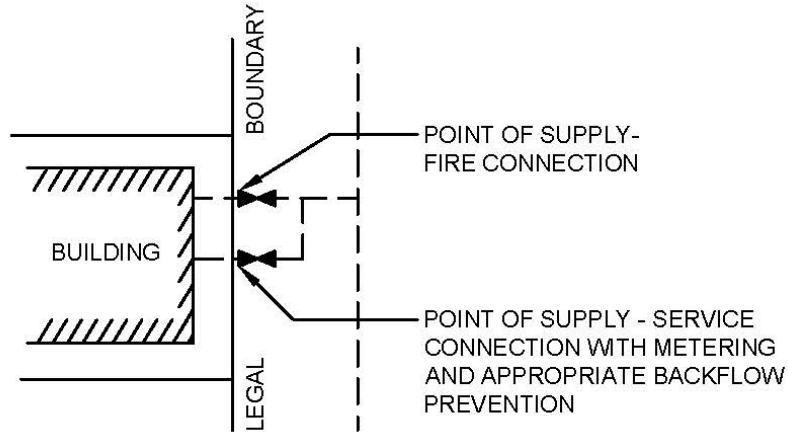

**COMBINED FIRE AND SERVICE CONNECTION**

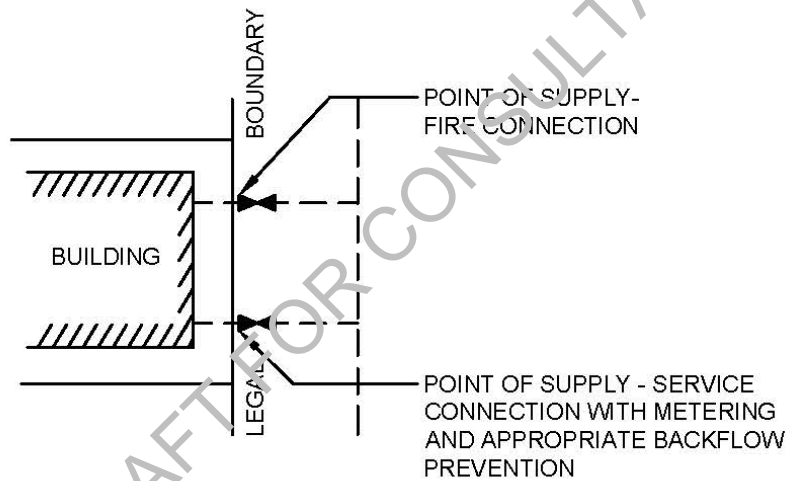

**SEPARATE FIRE AND SERVICE CONNECTIONS**

NOTE –  
Point of supply is tail piece of boundary box, meter or service valve regardless of property boundary.

**Figure 6.3d - Point of supply for industrial/commercial service and fire connections (NPDC only)**  
Refer to bylaws for SDC and STDC.

**6.3.16.3 Water Meters and Flow Restrictors**

Unless agreed otherwise by the Authorised Officer, separate water meters shall be installed for each industrial and commercial unit. Water meters shall be located in a position previously agreed by the Authorised Officer. For restricted flow connection in the rural supply areas a flow restrictor shall be incorporated for all connections.

The Council shall retain ownership of the meter. The Council shall be responsible for the repair, maintenance and replacement work up to the consumer side of the meter, except where malfunction or damage is the result of actions by the consumer.



*Standard meter boxes (for use on grass berm) shall be rectangular; with minimum dimensions 200mm x 300mm clear access, and be at least 200mm deep.*

*Larger boxes accommodating up to three meters shall be used when meters are installed side by side. Heavy-duty meter boxes (for use in trafficked areas) shall be designed and constructed in special cases. Where four or more meters are to be installed side-by-side a combination of boxes shall be used.*

#### **6.3.16.4 Backflow Preventers**

*The purpose of installation of backflow prevention devices is to prevent contaminated water from being drawn back into the water reticulation mains. The TA has adopted the Water New Zealand Backflow Prevention for Drinking Water Suppliers, Code of Practice, 2006.*

*The Code of Practice classifies the risk categories as follows:*

- 1. High Hazard: Any condition, device or practice which, in connection with the potable water supply system, has the potential to cause death.*
- 2. Medium Hazard: Any condition, device or practice which, in connection with the potable water supply system, has the potential to injure or endanger health.*
- 3. Low Hazard: Any condition, device or practice which, in connection with the potable water supply system, would constitute a nuisance, by colour, odour or taste, but not injure or endanger health.*

##### *High Hazard Connections*

*For high risk service connections, a specifically designed Reduced Pressure Zone (RPZ) backflow preventer assembly with isolation valves either side shall be installed as detailed in Fig 6.3e. The installation will require the approval of the Authorised Officer.*

##### *Medium Hazard Connections*

*Medium risk service connections which will typically be 25mm NB or larger require a double check valve assembly backflow prevention device, as detailed in Fig 6.3f, which is able to be tested.*

##### *Low Hazard Connections*

*Backflow prevention devices will be fitted to all service connections unless otherwise approved by the Manager Water & Wastes. For domestic and rural connections which have been assessed as low hazard, the backflow preventer shall comprise a dual check valve cylindrical assembly within the boundary box manifold, the low risk assembly is not able to be tested.*

*High risk hazard connections may involve (but are not limited to) situations where on site pressure boosting occurs or chemical or biohazard material, could be drawn into the distribution main.*

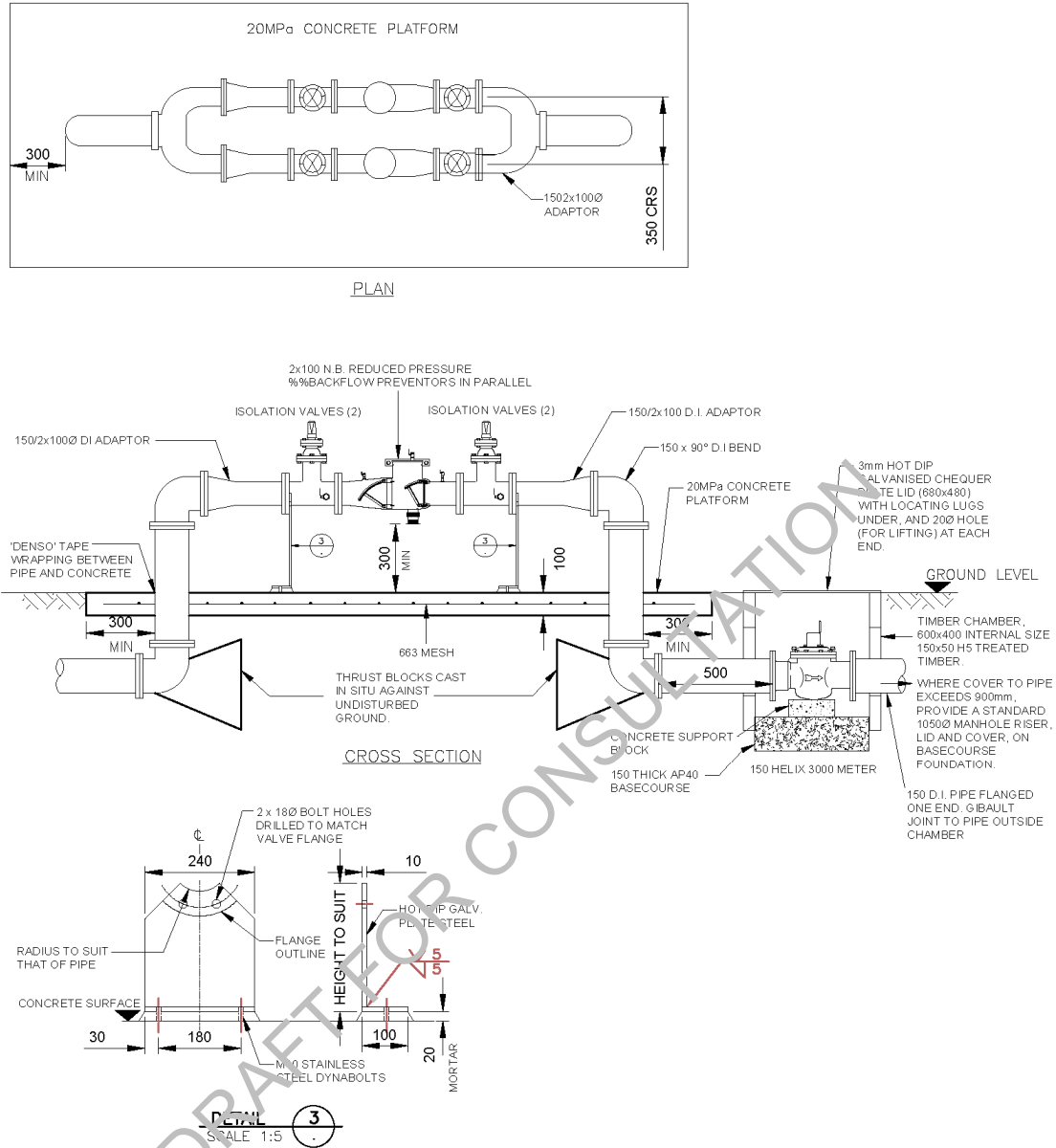
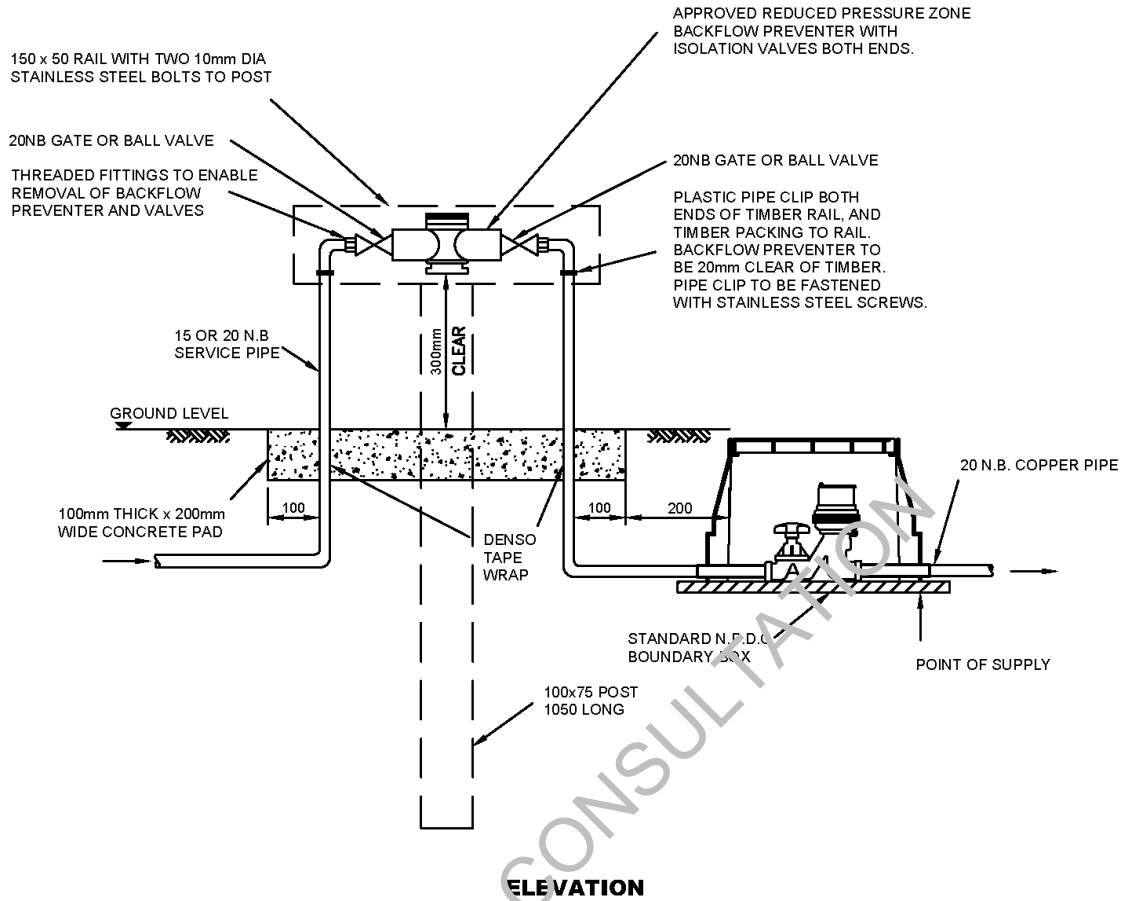

Figure 6.3e - Backflow prevention on 150mm dia water main



**NOTES –**

1. All work to be done in accordance with NPDC waterworks specification.
2. Use standard NPDC boundary boxes equipped with water meter.
3. Locate in road reserve approximately 500mm clear of private property.
4. Timber post and rail to be rough sawn H5 treated.

**Figure 6.3f - 20mm NB backflow preventer (NPDC only)**

### 6.3.17 Termination points

Termination points or dead ends should be avoided to prevent poor water quality. Alternative configurations such as a continuous network, link mains, looped mains, and the use of reticulation mains smaller than DN 150, particularly in no-exit roads, should be considered (see Figures 6.4 and 6.5).

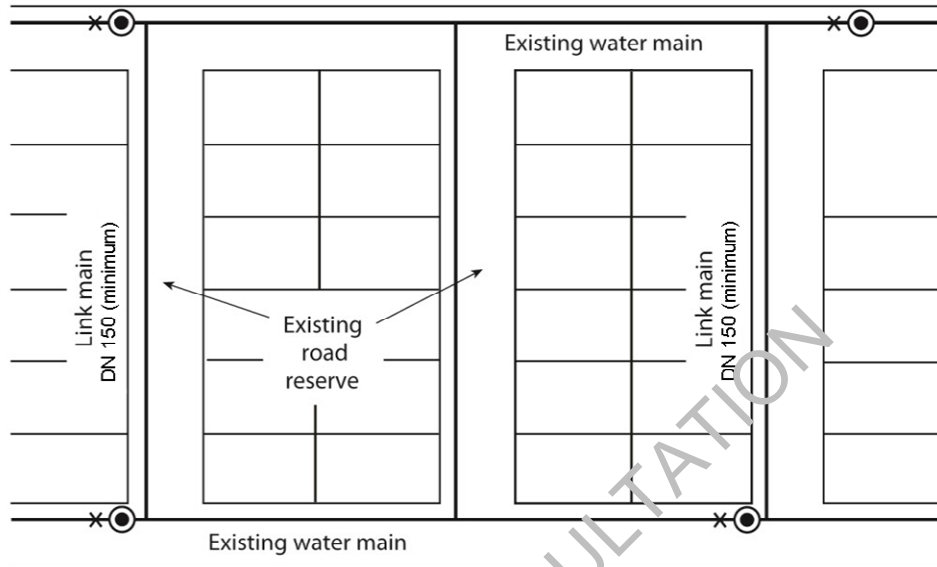

NOTE –  
Rider mains, valves and hydrants now shown.

Figure 6.4 - Elimination of termination points

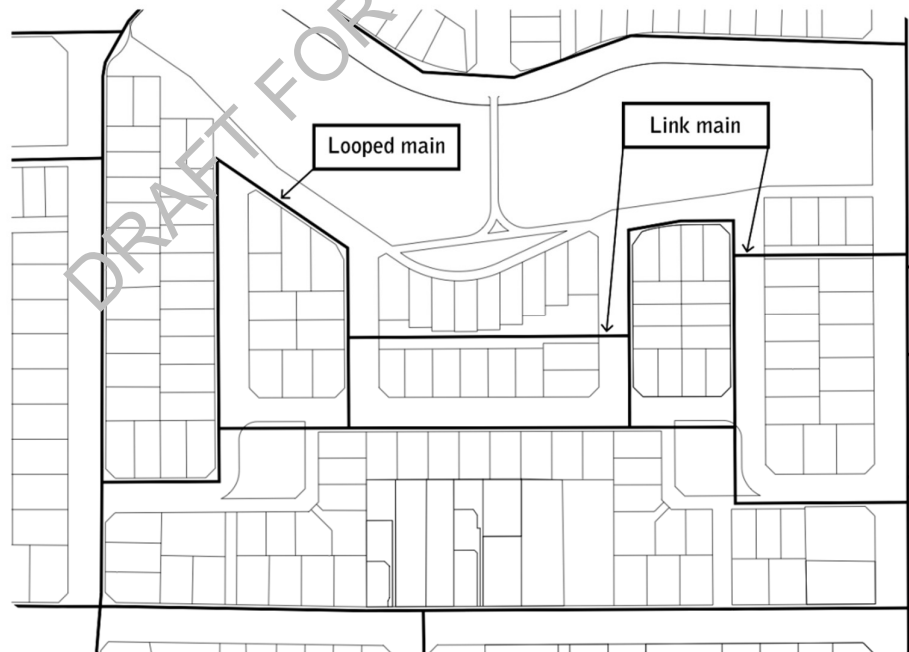

NOTE –  
Rider mains, valves and hydrants now shown.

Figure 6.5 - Looped and link principal mains

**6.3.17.1 Permanent ends of water mains**

Rider mains,  $DN < 150$ , may be used to supply the furthest properties beyond the water main. The  $DN 150$  main shall be laid to a point where all properties are provided with the fire protection required by SNZ PAS 4509.

A method of flushing shall be provided at the end of the rider main and water main, which shall be suitably anchored (see Appendix B drawing WS – 002).

**6.3.17.2 Temporary ends of water mains**

Water mains shall be laid to within 1 m of the boundary of a subdivision where the main is to be extended in the future.

*Temporary dead-end mains shall terminate with a hydrant followed by a gate valve, unless alternative arrangement is approved by Council.* The valve and hydrant shall be suitably anchored so that the future extension can be carried out without the need to disrupt services to existing customers.

Where a development is staged mains shall be constructed to terminate approximately 2 m beyond the finished road construction to ensure that future construction does not cause disruption to finished installations.

**6.4 Approval of proposed infrastructure****6.4.1 Approval process**

Water supply infrastructure requires approval from the TA.

**6.4.2 Information to be provided**

Design drawings compatible with the TA's concept plan and the design parameters included in this Standard shall be provided to the TA for approval. Designers shall ensure the following aspects have been considered and where appropriate included in the design:

- (a) The size (or sizes) of pipe work throughout the proposed reticulation system;
- (b) Selection of appropriate pipeline material type/s and class;
- (c) Mains layouts and alignments including:
  - (i) Route selection
  - (ii) Topographical and environmental aspects
  - (iii) Easements
  - (iv) Foundation and geotechnical aspects
  - (v) Clearances, shared trenching requirements
  - (vi) Provision for future extensions;
- (d) Hydraulic adequacy including:
  - (i) Compliance with the required maximum and minimum operating (working) pressure
  - (ii) Acceptable flow velocities, and
  - (iii) Compliance with the estimated water demand, including firefighting;
- (e) Property service connection locations and sizes;
- (f) Types and locations of appurtenances, including:
  - (i) Stop valves
  - (ii) Pressure reducing valves (PRVs)

- (iii) Hydrants and fire services
- (iv) Scours and pump-out branches and
- (v) Termination details;
- (g) Locations and details of thrust blocks and anchors, see Appendix B drawings WS – 004 and WS – 005;
- (h) Preparation of final design drawings, plans (and specifications if applicable).

## 6.5 Construction

*All water reticulation shall be constructed in accordance with TA Standard Specification for water supply.*

### 6.5.1 Excavation

Excavation of existing carriageways shall conform to the TA's road opening procedures where these exist. Excavation in existing carriageways shall be carried out in a safe manner with the minimum disruption to traffic and pedestrians.

### 6.5.2 Embedment

Pipes and fitting shall be surrounded with a suitable bedding material in accordance with Appendix B drawings CM – 001 and CM – 002.

### 6.5.3 Backfilling and reinstatement

#### 6.5.3.1 Carriageways

Backfilling shall be in accordance with the requirements of the TA.

Pipe trenches within a carriageway shall be backfilled using an approved hardfill placed immediately above the pipe embedment and compacted in layers not exceeding 200 mm in loose depth, as per Appendix B drawing CM – 002.

In existing sealed roads, the top section of the trench shall be backfilled as specified by 3.4.2.3. The depth of base course and type of finishing coat seal shall conform to the standard of the existing road construction.

#### 6.5.3.2 Berms

Pipe trenches under grass berms and footpaths shall be backfilled in accordance with the requirements of Appendix B drawing CM – 002.

#### 6.5.3.3 Marking tape

Open trenching – backfill shall be placed to 100 mm below existing ground level. At this point, where required by the TA, the contractor shall provide and lay *plastic marking* tape coloured blue, stipulating 'Danger – Water Main Below' (or similar). See Appendix B drawing CM – 001.

#### 6.5.3.4 Tracer wire

Tracer wire in the form of a continuous 4 mm<sup>2</sup> multi strand (minimum 4) polythene sleeved copper cable, shall be installed with all non-metallic pipes to allow detection. The wire shall be strapped to the pipe wall by means of a minimum of two complete wraps of heavy duty adhesive tape, at a maximum of 3.0 m intervals. The wire shall have some slack to allow for bends in laying and for future installation of tapping saddles.

The tracer wire shall run continuously between valves and hydrants. At each valve or hydrant the wire shall be *brought up* to surface level ending immediately below the lid, The tracer wire shall be long enough to extend 600 mm minimum above ground level when uncoiled. The excess length shall be neatly coiled in the valve or hydrant box.

The tracer wire shall be tested for continuity between surface boxes using an electronically generated tone and detector probe or alternative approved method.

*Tracer wire shall be installed on all watermains and rider mains, and service connections to the point of supply.*

#### **6.5.4 Pressure testing of water mains**

Before a new water main is connected to the existing reticulation, a successful pressure test shall be completed. The system test pressure is applied to test the integrity of construction of the pipeline system. *The system test pressure generally exceeds the actual design pressure of the system (1.5 times the maximum rated operating pressure of the lowest rated component in the system or 1400 kPa whichever is the lesser).* See Appendix C for the appropriate testing procedure.

#### **6.5.5 Disinfection of water mains**

*All parts of the reticulation which will be in contact with potable water shall be disinfected in accordance with the procedure described in Appendix D Amended.*

#### **6.5.6 Discharge of testing water**

Discharge of testing or chlorinated water from pipelines may require a resource consent from the regional council.

#### **6.5.7 Water sampling**

The TA *shall* require water samples to be taken for water quality compliance purposes.

DRAFT FOR CONSULTATION

## **7 LANDSCAPE**

### **7.1 Scope**

This section sets out requirements for the design and construction of landscape and planting for land development and subdivision. Section 7 applies to all landscape areas requiring planting and revegetation whether in road reserves, swales, rain gardens, ponds/wetlands, recreation reserves, or other public reserves, and private land.

### **7.2 General**

#### **7.2.1 Approval**

Consultation with the TA on landscape design and construction at an early stage of the design development is recommended. Each TA may have specific landscape guidelines which will be detailed in district plans or codes of practice and some areas may be subject to special landscape requirements which will need assessment through a resource consent process. These may be subject to specific design consideration and approval by the TA. Stormwater systems including secondary flow paths shall be considered when landscape designs are determined, so as to avoid conflict or failure of these systems.

#### **7.2.2 Environmentally-responsive design**

Landscape design has application throughout the subdivision and development process. Landscape design should be considered in the early stages of a development and at this initial concept stage it is important to establish objectives for overall landscape design involving the appropriate professionals to assess the natural systems, vegetation, and landscape features. This includes consideration of protecting, maintaining, and restoring existing natural ecosystems, vegetation, and landscape features; responding to the surrounding landscape character and context; and cultural and heritage elements; and contributing to ecological and habitat biodiversity. Provision of amenity open space and access is required to make open space connections, access to and location of watercourses, and provision of reserves and streetscape to provide a framework of coherence and amenity.

#### **7.2.3 Reserves and land protection covenants**

Layout plans and location of reserves and land protection covenants should be discussed with the TA prior to the lodgement of finalised plans. Development plans for all future reserves shall be submitted with application for engineering approval, and no work is to be carried out on site before the TA approval is issued.

All reserve development shall be completed in accordance with the plans acceptable to the TA. 'As-built' plans shall be provided for all reserves. Development may include earthworks, drainage, planting, paths, structures (such as seating, tables, litter bins, fencing, barriers, signs, and play equipment) and facilities (such as toilets and changing sheds) as specified by the TA.

#### **7.2.4 Ecological, functional, and aesthetic opportunities**

Planting provides a range of ecological, functional, and aesthetic opportunities for environmental enhancement:

- (a) Ecological:
  - (i) Provides, protects, and maintains terrestrial biodiversity and habitat
  - (ii) Reduces the amount of sediment and pollutants entering waterways
  - (iii) Maintains and enhances water quality and habitat
  - (iv) Reduces surface water flooding
  - (v) Increases stability and contributes to erosion control



- (vi) Supports carbon sequestration
- (vii) Supports ecosystem functioning including nutrient recycling, water retention, purification, and sediment control
- (viii) Provides wildlife habitat value;
- (b) Functional:
  - (i) Defines space
  - (ii) Provides shade, shelter, and privacy
  - (iii) Screens unsightly outlooks and provides visual barriers
  - (iv) Ameliorates sound and reduces pollution
  - (v) Assists driver recognition of road link and place context
  - (vi) Reduces glare and reflection and provides urban cooling
  - (vii) Assists in the control of erosion
  - (viii) Creates physical barriers
  - (ix) Provides recreation and amenity value
  - (x) Provides edible species
  - (xi) Provides opportunities for enhancing health, and should not be detrimental to it;
- (c) Aesthetic:
  - (i) Frames views
  - (ii) Emphasises landform and landscape features
  - (iii) Provides visual unity in the environment
  - (iv) Reduces the visual impact of the roadway
  - (v) Softens hard surfaces and bleak areas
  - (vi) Provides colour, form, and texture
  - (vii) Provides visual lineage within and between regions
  - (viii) Provides identity and environment.

### 7.2.5 Landscape and planting opportunities

Opportunities for landscaping are diverse, ranging from specimen tree planting to planting associated with existing indigenous vegetation, traffic management devices, riparian margins, wetlands, swales, rain gardens, ponds, reserves, and specific landscape features in the development.

## 7.3 Design

### 7.3.1 Location

Landscaping and planting should be designed to respond to the overall environmental context such as vegetation and water bodies, cultural and heritage elements, local road geometry, stormwater and reserve design, and utilities placement. Planting may include specimen trees, edible gardens, rain gardens, swales, and other amenity garden features. TAs may have their own requirements and standards that need to be met.

Infrastructural services should be planned at the same time as the landscape design so that tree and garden planting location does not compromise the integrity and efficient operation of services. If particular landscape conditions or objectives are required for a subdivision or development then these will need to be taken into account prior to undertaking detailed engineering design.

*Vegetation proposed to be planted in close proximity to overhead electricity lines and underground electricity cables should be selected and located in a manner that will not result in interference with utility services or a breach of the Electricity (Hazards from Trees) Regulations 2003.*

### **7.3.2 Reserve location and layout**

Reserve location and layout design shall take into account adjoining land uses and areas to ensure there is an appropriate provision of recreation assets and landscaping in accordance with TA's plans and policies. The design of access routes into and through a reserve should ensure linkages with existing networks, consider future developments both of the reserve and adjoining areas, take into account topography, and shall follow CPTED principles.

*All paths and tracks shall be designed and constructed in accordance with the Council's Path and Track Manual.*

### **7.3.3 Existing vegetation and trees**

All existing vegetation and trees to be retained shall be cordoned off to protect the root zone and vegetation, prior to the commencement of construction and the cordon shall remain in place until completion of construction.

Existing trees to be retained are to be protected by temporary fencing in a circle with a radius equal to the maximum crown extension (drip line). A qualified person shall be used to determine the protected area and supervise construction. At no time shall anything be deposited in the root zones of protected vegetation and trees. If installation is required under existing vegetation trenchless technology should be considered, if this is not practicable advice from a suitably qualified person should be sought to minimise damage to the vegetation.

A tree or vegetation plan and construction methodology shall be supplied to the TA including:

- (a) Position and design of temporary protective fencing or other methods of protection;
- (b) Arboricultural maintenance required;
- (c) Methods of protection of tree and root zone where construction is to occur near the root zone and tree canopy;
- (d) Maintenance required for long term health and stability of the tree or vegetation.

### **7.3.4 New trees and road geometry**

Separation and sight distances should be considered when planting on roads. Alternative location and design proposals shall also be considered, such as provision of trees in a dedicated area or 'non-services' berm in the road reserve. Tree planting in groups can help accentuate road perception (see 3.3.5). Strategically placed, grouped plantings of trees are often of greater benefit and impact than individual trees placed linearly in a roadside berm.

### **7.3.5 Planted grass areas, berms, swales, or rain gardens**

Berms, swales, or rain gardens shall be of sufficient width to allow for adequate growth of the plants and ease of maintenance. Narrow grass strips should be avoided. It is important to provide adequate means for tree growth and ongoing tree health at the same time as allowing for infiltration of water.

### **7.3.6 Species selection**

In selecting species for planting, take into account the overall composition, low maintenance, and longevity, as well as the need to comply with the TA's planting policies. *Refer to the relevant TA for a list of suitable species for the subject location.*

The spacing of trees and plants should ensure a coherent design. The following matters shall be considered:

- (a) Suitability of eco-sourced native plants for revegetation planting of the ecological region to protect the local biodiversity;
- (b) Suitability to environmental conditions, for example climate, ground moisture, wind, and shade;
- (c) Tolerance to high foot traffic use where appropriate;
- (d) Pest and disease resistance, invasive or recognised as a pest plant under the National Pest Plant Accord (refer to <http://www.biosecurity.govt.nz/nppa>);
- (e) Non-suckering habit;
- (f) Final height, form, and longevity;
- (g) Maintenance requirements;
- (h) Safety such as toxicity of leaves, flowers, seeds, and bark in areas likely to be used by young children, and impairments to pedestrians;
- (i) *The proximity to existing electricity infrastructure and the ability for planting to comply with the Electricity (Hazards from Trees) Regulations 2003 on an ongoing basis*

Plant species on the road should be selected to avoid interfering with sight lines inconsistent with the target operating speed. The mature size of any tree or garden planting is to be assessed for each planting location and relative to the surrounding street environment.

### 7.3.7 Quality control

All plants shall be sound, healthy, vigorous, and free of any defects which may be detrimental to plant growth and development. In addition plants should have vigorous root and branch systems and plants supplied in pots should not be root bound. To ensure that plants adapt and thrive once planted they should be 'hardened off' prior to planting. Only species adapted to the site conditions shall be planted.

### 7.3.8 Landscaping structures

**7.3.8.1** Landscaping structures include (but are not limited to) sculptures, walls, fences, screens, bollards, tree cages, entranceways, and posts. The materials should be robust to suit their purpose and ideally reflect the local character. The design of the landscape structure shall be considered as an integral part of the development and surroundings to fulfil both functional and aesthetic requirements. Durability and maintenance requirements shall be considered. Structures shall not:

- (a) Inappropriately limit safe sight lines;
- (b) Be a hazard to pedestrians, people with disabilities, cyclists, or vehicle traffic.

*Parks name and directional signs shall comply with the Council's Outdoor Signage Manual.*

**7.3.8.2** Entranceway wall structures shall be located fully on private land unless TA approval is obtained. Any other immovable landscape structure (for example boulders) shall be located to prevent obstructing access to underground services.

**7.3.8.3** Structures shall be designed to safely withstand appropriate loadings. Structures not exempt under the Building Act shall only be constructed on receipt of a building consent.

Playground equipment shall comply with NZS 5828 and SNZ HB 5828.1.

All retaining walls including those not requiring a building consent should be constructed to resist lateral earth pressures and those from any surcharge loading that may be present.

*The design of park furniture, fences and structures shall be consistent with the Council's Parks Standards Manual.*

*A park sign, in accordance with Council's outdoor signage manual, shall be installed at each reserve.*

### **7.3.9 Fencing of reserves**

*The permanent fencing of common boundaries of any reserve including esplanade and accessway reserves, may be required. The Council may require a landowner to fence their roadside frontage of a new reserve where it is considered public safety or convenience renders it expedient. The Council may specify that one or both of the following options apply:*

- (a) A fencing covenant is registered on all titles of properties with a common boundary to reserve land, indemnifying the TA against all costs of erection and maintenance of fences on common boundaries;
- (b) There is a specific fencing design for the reserve or boundary type *in accordance with the Parks Standards Manual*.

#### **7.3.9.1 Naming of Reserves**

*Naming of reserves shall be in accordance with the Council's General Policies for Council Administered Reserves.*

### **7.3.10 Planting period and irrigation**

Planting programmes where possible shall occur in the season that optimise growing conditions for plants and trees and maximises plant establishment.

The TA may require provision for permanent or temporary irrigation of specimen trees, gardens, or plantings. *A suitably qualified person shall determine the need for permanent or temporary irrigation and the length of establishment time (a period of not less than 18 months and not exceeding 36 months) where temporary irrigation is required.*

## **7.4 Construction and maintenance**

### **7.4.1 Introduction**

There are minimum construction and maintenance standards and recommended procedures to be followed to ensure that all landscaping is to an acceptable standard prior to final inspection and release of the bond, if a bond is required.

It is the developer's responsibility to ensure that the landscaping meets the required standards at the termination of the maintenance period. The developer is responsible (and may be bonded) for the routine maintenance and replacement of the planting including dead wooding, weed control, mulching, replacing dead trees, shrubs, plants, *and grass berms* and watering for a defined period from the time of acceptance of as-built landscape plans by the TA or issue of a s.224 completion certificate under the Resource Management Act.

### **7.4.2 Soil and fertility**

*The developer shall be responsible for the supply and spreading of soil. Topsoil should be correctly stored and handled when stripped and re-spread. Any imported topsoil and fill soil shall be free of debris (including stones) greater than 7 mm. Soil tests may be required to determine compaction, composition and fertility prior to preparation for planting. A suitably qualified person will interpret test results and provide a programme to remedy deficiencies which may affect plant species to be used both pre and post planting.*

*No blanket spraying of areas may occur without prior approval from the Authorised Officer. Any blanket spraying shall be in accordance with NPDC Agrichemical Policy.*

### **7.4.3 Weeds and litter control**

At the end of the maintenance period there shall generally be no weeds within 2 m of any tree planting or in garden beds. Weeds should be controlled in an appropriate manner. When hoeing/pulling weeds care shall be taken to avoid damage to plants and their roots. The soil shall not be mixed with mulch

when removing weeds. Any spraying should be kept to a minimum near swales, rain gardens, ponds, riparian margins, and adjacent properties.

All areas once established shall be kept free of litter and debris, including paper, plastic, stones, bricks, bottles, glass, cans, and other forms of inorganic matter.

#### **7.4.4 Planting grass areas**

**7.4.4.1** Grass areas and berms shall be formed after all other construction has been completed. The grass areas and berms shall incorporate not less than 100 mm compacted thickness of friable weed and stone free topsoil (generally made up of a composition of approximately 1 – 5% sand, 7 – 16% humus or organic material, and no more than 30% weight in clay) placed over a base material capable of allowing root penetration and sustaining growth. The maximum slope for grass areas intended to be mown is 1:5.

**7.4.4.2** Heavily compacted soils shall be ripped to a depth of 300 mm with rip lines 1 m apart, and rolled, before any laying of topsoil. The ground profile shall be smooth and free of ruts and depressions prior to grassing. Ripping to decompact soils should not be undertaken within the dripline of trees to be retained. Grass areas and berms shall be graded to edges (for example, pavement or footpath) allowing for approximately 15 mm of settlement.

**7.4.4.3** Rural berms shall be topsoiled to the same standards as urban berms unless they make use of already grassed undisturbed ground.

**7.4.4.4** The area for grass seeding shall be free of all weed species. *Grass seed mixes shall be approved by the Council.* Other special purpose grass seed and plant species may be used in special areas such as swales and rain gardens.

**7.4.4.5** A sward coverage of not less than 90% shall be achieved within 1 month of sowing, and before completion documentation shall be provided for processing by the TA. All established grass shall be mown to a range specified by the TA. A common mowing height range is a minimum height of 50 mm and maximum height of 100 mm. All grass edges shall be maintained in a neat and tidy manner.

##### **7.4.4.6 Grass planting mixes**

- *Only sports turf specific grass seed that is approved by the Council will be acceptable.*
- *SR 4600 and SR 4650 type grass seed is to be used in all reserve areas at present.*
- *New varieties will be considered as they become available.*

#### **7.4.5 Mulch**

**7.4.5.1** Mulch shall be applied to tree and garden areas to conserve moisture and reduce weed growth, except in riparian margins. Typically mulch will be cambium grade bark mulch, clean, free of sawdust and dirt, and with individual pieces no larger than 100 mm; mulched trees/branches that have no viable seeds; or stone mulches. Mulch for planting beds shall be a uniform 100 mm in final depth. Edges shall be formed to hold the mulch without spillage on to adjacent surfaces. Before mulching soil should be damp to a depth of 300 mm. Mulching should be carried out on an ongoing basis to all garden beds and juvenile trees to maintain specified depth at end of maintenance period.

**7.4.5.2** Mulch shall only be spread after the soil surface is levelled off to remove bumps and hollows. Weeds and grass are to be removed prior to mulching. Plants shall not be damaged or buried during the mulching process. Where it is known that bark mulch affects certain species or will be lost due to wind, slope of the land, or for some other reason, alternative mulches shall be considered and used.

## 7.4.6 Specimen tree planting

**7.4.6.1** Specimen trees are defined as trees with a trunk diameter of 25 mm to 100 mm when measured at 1400 mm above ground level. Larger trees can be used with the approval of the TA.

Those contractors involved in specimen tree planting and maintenance should be competent horticultural/ arboricultural practitioners and therefore follow accepted industry standard procedures for tree planting *as outlined in the District Tree Policy, where applicable*. Establishment and initial maintenance are critical to the long-term viability of the specimen tree.

**7.4.6.2** Specimen trees shall be sound, healthy, vigorous, and free of any defects (relative to the species). Specimen trees are to be a minimum of PB 95 (planter bag of 95 pint capacity approximately 54 L) grade when planted. A recommended minimum height for specimen trees is 2.5 m at the time of planting to aid early establishment unless the local conditions of a site require consideration of alternatives, for example, an exposed site may require small, well-hardened trees. Specimen trees between 1.5 – 2.5 m may be allowed with the approval of the TA.

**7.4.6.3** Given the generally modified nature of soil in subdivisions it is essential that a suitable tree planting pit be prepared. The approach shall be to have:

- (a) Ground free from debris and rubbish;
- (b) Ground cultivated to a depth of 1 m and a width of 1 m to break up any compaction, fracture subsoil, and afford drainage to hard rock areas;
- (c) Sides of planting holes crumbled and not smooth;
- (d) Topsoil incorporated into the upper level of planting holes;
- (e) Each tree fertilised with an appropriate amount of slow release fertiliser, as per the manufacturer's recommendations;
- (f) Final planted depth *to allow 60 - 100 mm mulch* consistent with finished ground level;
- (g) Each tree adequately staked to withstand movement in natural wind conditions and to meet TA standards;
- (h) Trees secured with expandable ties at approximately 1/3 of their height or as high as required to support the tree (to be checked every 6 months) or anchored below ground with a root ball anchor;
- (i) Soil firmed sufficiently to force any air pockets from planting holes;
- (j) Trees watered immediately following planting;
- (k) Trees radially mulched to a distance of 500 mm or to drip line, whichever is the greater area and a depth of 60 - 100 mm *unless approved mowing/containment strips are provided*; and
- (l) Staking uniformly low and visually consistent throughout the subdivision stage. Ground-treated timber stakes should only be used if the stakes are to be removed once the trees are stable, that is at the end of a maintenance period.

**7.4.6.4** The onus is on the developer to ensure that trees are protected during the further development of the subdivision (that is, the construction of dwellings/buildings) and during the defined maintenance period.

**7.4.6.5** *For purposes of clarification, where applicable the Council's Tree Policy shall take precedence over these clauses. In the event of a dispute in this matter, the TA shall make a determination.*

## 7.4.7 General amenity planting

Before topsoil is added all stripped and graded ground intended for planting should be cultivated to a depth appropriate to the plant species including a sufficient depth to break up any compaction. There should be friable topsoil for shrubs and ground cover appropriate to the depth of the root ball.

### 7.4.8 Revegetation planting and existing vegetation

Revegetation planting shall be a minimum grade of PB3 (planter bag) or root trainers and shall be planted at a density and size of plant that achieves a coverage ratio specified by the TA or appropriate to form the desired canopy density. Plants shall be spaced unevenly in the planting layout to encourage a natural appearance and setting.

Assisted natural revegetation is a technique using native seedling establishment complemented with weeding, thinning, and mulching and is an option that may be considered.

Edges of existing vegetation, to be retained where appropriate, shall be planted to mitigate the effects of wind funnelling. Mulches can be used in these areas to minimise the establishment of weed species.

### 7.4.9 Swales, rain gardens, wetlands, and riparian margins planting

Swales, rain gardens, wetlands, and riparian margins should have site specific planting plans prepared by a suitably qualified person and submitted to the TA for approval of designs. Access shall be provided if future removal and maintenance is required.

### 7.4.10 Pruning

**7.4.10.1** Trees should be selected and located to minimise ongoing pruning costs and requirements. All pruning of street trees shall be undertaken by a suitably qualified arborist. All pruning shall be undertaken to recognised arboricultural practices.

Pruning should be carried out on shrubs to maintain a high standard of presentation, display, and plant vigour. Paths, roads, and all other accessways should be kept clear of excess growth. Pruning may also be necessary to ensure signs are not obscured. Where appropriate pruning should allow for adequate sight visibility to ensure the safety of road users. However there are situations where planting should be used to restrict visibility and slow traffic or frame views.

**7.4.10.2** All weak, dead, diseased, and damaged growth should be removed, and pruning carried out to maintain the desired shape and size. *Pruning should be carried out at a time appropriate to the species by a suitably qualified Council approved contractor.* The following pruning techniques (for shrubs) should be employed where appropriate:

- (a) Tips to be pinched or purged as appropriate for species to give desired shape and size;
- (b) Form pruning of young plants to ensure compact form and shape;
- (c) Undercutting of groundcovers at edges generally;
- (d) Plants are to be pruned so that they do not smother neighbouring plants.

### 7.4.11 Maintenance

**7.4.11.1** Landscape plans shall ensure that future maintenance requirements have been considered so that ongoing costs are minimised. The maintenance period will vary depending on the nature type of planting and should be covered in specifications and as required by the TA. *This maintenance period shall be a period of not less than 18 months and not exceeding 36 months.*

The developer shall:

- (a) Remove from the area all temporary services, machinery, and surplus materials that have been used for the construction, and leave the site in a tidy condition;
- (b) Clean all paths and surrounding areas;
- (c) Remove all plant labels;
- (d) Clear and weed all channels;
- (e) Ensure that all damaged, vandalised, stolen, or dead plants are replaced to maintain numbers and unity of display;

- (f) Ensure that amenity planting beds are cleaned to remove prunings, dead or damaged leaves, and any other object or material, including retail attachments such as labels. The edges of the beds shall be left evenly shaped and sloped.

Land to be vested for reserves purposes shall as a minimum meet the following general requirements:

- (g) The land is to be free of noxious weeds, tree stumps (above ground) and other specified vegetation;
- (h) All previous fences, farm utilities, building remains, and rubbish are to be removed or disposed of to the satisfaction of the TA;
- (i) Land to be mown shall be accessible to suitable mowing equipment, and is to have an established turf type seed grass cover;
- (j) Drainage reserves, ponds, lakes, channels, and streams requiring maintenance shall have suitable access for machinery;
- (k) All boundaries are to be surveyed and clearly pegged;
- (l) Any rights of way or easements are to be formalised at no cost to the TA;
- (m) Any proposed landscape planting or furniture/structures shall be completed.

DRAFT FOR CONSULTATION



## 8 NETWORK UTILITY SERVICES

### 8.1 Scope

This section sets out requirements for the provision of stormwater, wastewater, and water supply systems, power, telecommunications and gas, and their locations in the road. The scope of these provisions applies to both future and existing roads and applies equally to all network utility services.

Note – Network utility services in roads are subject to the Utilities Access Act 2010 and the Infrastructure (Amendments Relating to Utilities Access) Act 2010.

### 8.2 General

#### 8.2.1 Legislation

Referenced legislation and documents are listed in the Referenced Documents section of this Standard.

#### 8.2.2 Definitions

For the purpose of section 8 the following definitions shall apply:

<b>Code</b>	Means the national code of practice approved in accordance with the Utilities Access Act 2010
<b>Corridor manager</b>	Has the same meaning given to it by the Utilities Access Act 2010

#### 8.2.3 Context

The developer is required to make all arrangements with the appropriate network utility operators for the supply and installation of stormwater, wastewater, water supply, and electric power and to the extent applicable for the provision of telecommunication and gas reticulation.

The developer shall provide satisfactory evidence to the TA corridor manager that the network utility operators are prepared to reticulate the subdivision and that agreement on the financial arrangements for the installation of each supply has been reached. The following applies to each utility:

- (a) Stormwater, wastewater, and water supply. Where water supply and wastewater pipes, and stormwater systems are in the road reserve, they shall be installed at the time of road construction to the requirements of the TA corridor manager and the water supply authority for water pipes, or the TA for wastewater pipes and stormwater systems;
- (b) Electric power. The supply of electric power will generally be by means of an underground system. Ducts shall be installed at the time of road construction to the requirements of the electrical supply authority and the TA corridor manager. Where the developer is intending to provide electric power other than by underground system, the developer shall provide alternative supply arrangements for approval of the TA;
- (c) Telecommunications. Arrangements shall be made with the telecommunication supplier for the reticulation of telecommunication facilities. Where only part of this reticulation is being supplied initially the arrangements shall include the requisite space being maintained for the installation of the remainder of the reticulation at a later date. Ducts will be supplied to the subdividing developer at the time of road construction for installation in the carriageway formation to the requirements of the telecommunications supplier and the TA corridor manager;
- (d) Gas. Where an existing gas supply is available or likely to be available to serve a subdivision, the developer may make appropriate arrangements with the gas supply authority and the TA corridor manager, and at the time of road construction, install such ducts/pipes as may be required.

The developer shall follow the requirements of the Code to the extent that they apply to the utility installation for the development.

## 8.3 Design

### 8.3.1 Plans

Copies of the plans of the development/subdivision shall be forwarded by the developer to all of the affected network utility operators at an early date to facilitate the design of the reticulation.

#### C8.3.1

*It is important that all of the affected network utility operators are advised by the developer of any amendments to the development plan. Information when available on the type of dwellings and likelihood of more than one dwelling on any lot, will be valuable for design purposes.*

8.3.1.1 In preparing the engineering plans consideration shall be given to the requirements of the network utility operators and the TA corridor manager for:

- (a) Minimum cover to cables and pipes;
- (b) The network utility operator's desired position for the cable and piping within the road berm as agreed with the TA corridor manager;
- (c) The minimum separation distances between power or telecommunication cables, and gas or water mains;
- (d) The width of berm which shall be clear of other services and obstructions to enable efficient cable-laying operations.
- (e) *The requirements of NZS5258:2003, Gas Distribution Networks.*
- (f) *The requirements of the National Code of Practice for Utility Operators' Access to Transport Corridors.*
- (g) *The minimum separation distances between overhead power lines and buildings, structures and earthworks outlined in the New Zealand Code of Practice for Electrical Safe Distances NZECP 34:2001.*

#### C8.3.1.1

*Reference should be made to each network utility operator and the TA corridor manager for their specific requirements. Refer to the Code for further information.*

### 8.3.2 Utilities above ground

Utilities should preferably be sited within the road berm or on land which will legally become part of the road but which is set back outside the normal road line. Alternatively separate lots (public utility reserves) or easements over private property may be used. If there are any concerns raised about the safety of above ground structures, the risk should be assessed in accordance with the requirements of the Code and any significant risks mitigated.

## 8.4 Construction

### 8.4.1 Underground cabling

Underground cable laying shall be achieved by the most appropriate method considering the nature of subsoil and potential damage to infrastructures and shall be to the approval of the TA corridor manager.

#### C8.4.1

*The trenchless method is preferred in existing urban areas for underground cabling. Refer to the Code for further information.*

## 8.4.2 Materials

Materials and sizes of ducts and pipes shall comply with the requirements of the network utility operators and the colours should be in accordance with the Department of Labour's *Guide for safety with underground services*.

## 8.4.3 Conversion to underground on existing roads

Where a proposed subdivision fronts on to an existing road, the conversion of overhead reticulation to underground will in some instances be desirable. Agreement on the feasibility and benefit shall first be agreed between the network utility operator and the TA.

## 8.4.4 Commercial and industrial subdivisions

The servicing requirements for commercial and industrial areas are often indeterminate. Close liaison between the developer and the network utility operator is advisable, particularly immediately before cabling is installed so that changes can be incorporated to accommodate extra sites or the requirements of a particular industry.

## 8.4.5 Location of services

### 8.4.5.1 Position in the road

Position and depth shall be agreed with the appropriate network utility operator and the TA corridor manager in accordance with the provisions of the Code.

### 8.4.5.2 Recording of underground services

TAs shall maintain a procedure for recording the location of their underground services on plans which are readily available to the public at the TA office. It is unlikely that the TA will be able to provide a service for utility services other than those for which it is immediately responsible. These will usually be stormwater, wastewater, and water supply. Other authorities or network utility operators are required to maintain similar records of the existence and detailed location of their services for ready reference.

### 8.4.5.3 Accuracy and tolerance

It is essential that all services be laid to predictable lines if there is to be a reasonable opportunity of laying new services in existing systems. In addition to specifying the location of any service in the road berm, there should also be a tolerance which shall on no account be exceeded without proper measurement and recording on the detailed record plan. Tolerance of  $\pm 300$  mm in the horizontal and  $\pm 100$  mm in the vertical is a practicable requirement.

## 8.4.6 Trenches

8.4.6.1 When new subdivision construction is undertaken the backfilling and compaction of trenches to a state of stability consistent with the future of the surface shall be carried out in accordance with the Code and to the satisfaction of the TA corridor manager.

8.4.6.2 Where underground services are laid after the initial construction of the subdivision or where they are extended from an existing area into a new one, special attention shall be given to the opening and reinstatement of trenches in accordance with the Code and to the satisfaction of the TA corridor manager.

### *C8.4.6*

*TAs are recommended to prepare standard specifications for the opening of trenches and the restoration of surfaces. Network utility operators are in turn recommended to comply with the requirements of such specifications.*

*Refer to the Code for further guidance*

## **APPENDIX A – ACCEPTABLE PIPE AND FITTING MATERIALS**

(Informative)

*Appendix A of NZS 4404:2010 has been replaced with the following list of Acceptable Pipe and Fitting Materials approved for use in New Plymouth, South Taranaki and Stratford Districts.*

*Please also refer to the New Plymouth District Council website for lists of Acceptable Pipe and Fitting Materials approved for use in New Plymouth, South Taranaki and Stratford.*

DRAFT FOR CONSULTATION

**WASTEWATER APPROVED PRODUCTS NEW PLYMOUTH DISTRICT COUNCIL****DEC 2009**

Notes: All parts of the waste water reticulation system shall be designed using components and materials that comply with AS/NZS Standards

	Category/Material	Standard	Comment	Application	Manufacturer
<b>1</b>	<b>Wastewater Pipe</b>		# Trunk mains: larger than 300mm These to be specifically approved & specified by council. # Reticulation mains:- 150mm # Lateral connection:- 100mm # Rising main min 63mm		
1.1	Spiral- welded steel pipe internal linings include concrete or epoxy	NZS4442:1988 or AS1579:1993	Polyken YG111 external wrapping or "Speed Steel" with polyethylene coatings. Note internal coating must be resistant to hydrogen sulphate.	Specific design Structural mains	Steel NZ Ltd
1.2	Ductile Iron Class K9/K12	AS/NZS 2280: 1995 & amendments	Light cement lined with Tyton joints. External protection with greensleeve. Generally suspended pipes and high structural loadings. Note internal coating must be resistant to hydrogen sulphate	Specific design Structural mains	Tubemakers, Australia (as supplied by Humes) (licence #2029)
1.3	Ductile Iron Pipe Light Cement Lined Tyton Excel PN 20 & PN 35	AS/NZS 2280: 1995 & amendments	With Tyton Joint elastomeric seals & socket/Spigot joints (with blue polyethylene sleeving) Note internal coating must be resistant to hydrogen sulphide.	Specific design Structural mains	Tyco Tyton Excel (licence #SMK0883)
1.4	uPVC pipes & fittings for gravity applications	AS/NZS 1260:2002 Class SN16 RRJ	uPVC is only to be used in applications of 200mm and less. Stainless Steel or Concrete Lined Steel are to be used in situations where a sewer crossing is needed.	Up to 200mm in reticulation only. (uPVC not to be used as trunk mains)	Iplex (licence # 2365) Marley (licence # P20184) Keyplas licence # 2622) RX Plastics
1.5	Polyethylene Pipe (PE) for gravity applications (minimum SN16)	AS/NZS 5056	Pipes shall be butt welded in accordance with the manufacturer's recommendations, & the standard coloured black with inner core colour white/grey or brown. Electrofusion couplings are not generally accepted.	Specific design situations	Iplex (licence # 1697) Marley (licence # 2365) RX Plastics

	<b>Category/Material</b>	<b>Standard</b>	<b>Comment</b>	<b>Application</b>	<b>Manufacturer</b>
1.6	MDPE for domestic rising mains.	AS/NZS 4129,4130,4131	MDPE pipe has to be rated to PN 12.5 or greater. No less will be accepted.	Specific design Council asset outside the boundary	Iplex (licence # 1697)
<b>2</b>	<b>Seal Rings</b>				
		Comply with AS 1646. 1:2000:	Elastomeric seals for wastewater purposes		Iplex (licence # 1697) Marley (licence # 2365)
<b>3</b>	<b>Fittings</b>				
3.1	i) Cast iron pipe flanged, socket & spigot fittings.  II) Cast iron flanges	i) AS/NZS 2280:1999  II) to Table D or raised, faced & drilled to AS 4087, & coated to AS/NZS 4158:1996 & amendments			Crevet Griptite (licence #943 & 950) Humes (Licence #2029) Surecast Tyco Tyton Joint (licence #PRD/R61/0412/1)
3.2	Stand Alone Flanges	Table D coated to AS/NZS 4158:1996 & amendments	PVC Ductile Cast Iron		Iplex Marley Unflanged adaptor - Di (as supplied by Steel & Tube NZ Limited)
3.3	Bolts, nuts & washers to be hot dipped galvanised	AS/NZS 1111 & 1112	ISO metric hexagon commercial bolts & screws, & ISO metric hexagon nuts, including thin nuts, slotted nuts & castle nuts		Steel & Tube NZ Limited

	<b>Category/Material</b>	<b>Standard</b>	<b>Comment</b>	<b>Application</b>	<b>Manufacturer</b>
3.4	Stainless steel bolts, nuts and washers are acceptable alternatives to hot-dipped galvanised fastenings provided that they are 316 grade stainless steel with factory applied molybond coating.	Comply with AS 1252:1983-High Strength Speed Steel Fastenings	This particularly applies for use in corrosive soil conditions		Steel & Tube NZ Limited
3.5	Gibaults  1/ Cast iron (coating as per standard)  2/ Gunmetal DR LG2 with ABS belly  3/ M16 316 stainless steel (with clips fusion coating as per standard)	4158:1996 & amendments Coating to ASTM A276  AS/NZS 4158	Use 316 Grade Stainless steel bolts. Preference for long barrel  Use 316 stainless steel fasteners		Gillies Steel & Tube NZ Limited Metal Tech
3.6	PE Fittings	AS/NZS 4129,4130,4131			Durafuse (licence #SA12420 & 2573) Iplex/Plasson Marley- Pushlok (licence #1494) Plassom (Licence #1494 & 1271)
3.7	<b>Boundary Kit</b> All fittings to be 316 Stainless Steel	AS/NZS 1546.1	All threads to be joined using hemp and graphite		Humes Steel and Tube NZ LTD

	Category/Material	Standard	Comment	Application	Manufacturer
<b>4</b>	<b>Valves</b>				
4.1	<b>Valves<sub>≥</sub> 50mm</b>  Resilient seated anti-clockwise closing Rated at PN16  External & internal protective coating  Flanges to be raised face & drilled as per standard	AS/NZS 2638.2:2003 NZS/BS 5163 Class1  AS/NZS 4158:1996 & amendments  AS 4087	Teflon gland packing or 2 or more "O" ring seals & dust cover. In-line valves shall be the same diameter as the reticulation main	Pump station and rising mains	AVK valves (licence #SA12420 & 2573) Gilliesb SF series Tyco Figure 500 series (licence #PDR/R61/0412/2) Crevet Ltd Norcast (licence #1327) Hawle 4060E2 & 4500E2AS series (licence #SMK20123)
<b>5</b>	<b>Manholes/Inspection Chambers</b>				
5.1	1050 to 2500 mm ID with precast external bases/internal bases are not generally accepted	NZS 3107:1978 NZS 3109:1997 NZS 3114:1987	<b>All manholes are to be installed in accordance with this code</b>		Humes Hynds
5.2	uPVC Access chambers 375mm	AS/NZS 4999	Point of access for maintenance and inspection equipment Not generally used over 1200mm deep  <b>Only to be used with prior approval from NPDC</b>	uPVC	Marley
5.3	Concrete lid (flat top) with 600mm openings	AS/NZS 1260 NZS 3107:1978	In carriageways, driveways, vehicle entrances and in all other areas which could be subject to vehicle loading, Heavy duty type shall be used. In other areas medium duty type may be used	1050mm to 2500mm manholes, if bigger it will be to an engineers design	Humes Hynds



	Category/Material	Standard	Comment	Application	Manufacturer
5.4	600mm access chambers for depth not exceeding 1.2m	NZS 3107:1978 NZS 3109:1997 NZS 3114:1987	<b>All manholes are to be installed in accordance with this code</b>	Concrete	Humes Hynds
5.6	Marker pegs	M14 specifications	Offset from sewer manholes allowing identification A <b>Red</b> disc will be attached to the marker peg identifying sewer		RTL
5.7	Manhole sealant	BM 100 or SM9020	Adheres to adjacent surfaces under sustained compression		Sika Humes Hynds
5.8	Manhole Steps 316 grade stainless steel safety step	AS/NZS 4158 AS/NZS 4020	Stainless Steel steps to be used in installation of all new manholes		Humes Hynds
5.8.1	Plastic encapsulated stainless steel safety step	AS/NZS 1657:1992 AS 4198:1994	Only to be used in cases of safety step replacement inside existing manholes		Safety Step Irons (Company Name) Humes Hynds
5.9	Cast iron manhole covers and frames: 600mm	BS EN 124 vehicle loading or AS3996-80kn loading	Heavy Duty Light Duty		Humes Hynds
5.9.1	Ductile iron manhole covers and frames	Grade 500.7 ISO 1083 EN124 Class D 400 ISO 9001 QAS	Clear opening 600mm Non Rock	To be used in urban streets with high volume traffic and all State Highways	PAMS BRIO
<b>6</b>	<b>Fittings</b>				
6.1	uPVC	AS/NZS 1260:2002			Iplex (licence # 2365) Marley (licence # P20184) Keyplas licence # 2622)
6.2	Rubber Sleeves	AS/NZS 4326:1995	Pipe clamps to be 316 Stainless Steel		Fernco

	Category/Material	Standard	Comment	Application	Manufacturer
<b>7</b>	<b>Pipe liners</b>				
7.1	NUFLOW		Trenchless Technology	Installed by VID-PRO	Nuflow(Vid-pro)
7.2	AM Liner Sideline pipe hardening Sideline structural pipe repair		Trenchless Technology	Installed by Pipe Technology	Pipe Technology
<b>8</b>	<b>Road Repair</b>				
8.1	QPR		High performance, permanent pavement repair (Cold mix)	To be used in minor patch repair situations	Downer EDI Works (Rifle Range Road NP)
8.2	BRP Road Patch		To be used around manholes as a patch on urban roading	To be used in minor patch repair situations	AJ Broom Road Products NZ Limited

DRAFT FOR CONSULTATION

**STORMWATER APPROVED PRODUCTS NEW PLYMOUTH DISTRICT COUNCIL****MAY 2010**

Notes: All parts of the Stormwater reticulation system shall be designed using components and materials that comply with AS/NZS Standards

	Category/Material	Standard	Comment	Application	Manufacturer
<b>1</b>	<b>Stormwater Pipe</b>				
1.1	Reinforced concrete pipe	AS/NZS 4058:2007	Pipe class depends on loading	All mains	Humes (Licence # 2618) Hynds (Licence # 2586)
1.1.2	Rubber ring joint				Humes (Licence # 2618) Hynds (Licence # 2586)
1.1.3	Flush jointed pipes		Not generally accepted	Specific design situations	Humes (Licence # 2618) Hynds (Licence # 2586)
1.1.4	Skid ring joint		Not generally accepted	Specific design situations	Humes (Licence # 2618) Hynds (Licence # 2586)
1.1.5	Roller compacted pipes	AS/NZS 4058:2007			Humes "Titan" (Licence # 2586)
1.2	Spiral-welded steel pipe Internal linings include concrete only.	NZS 4442:1998 or AS 1579:1993	Not generally accepted	Specific design situations	Steel pipe NZ Ltd
1.3	Ductile iron Class K9/ K12	AS/NZS 2280:2004 & amendments	Light cement lined with tyton joints. External protection with green sleeve Generally suspended and high structural loading Not generally used	Specific design situations	Humes
1.4	Polypropylene Twin wall pipe	AS/NZS 5065	Rubber ring joint (Blue Line)	Specific design	<b>Waters &amp; Farr (Storm Boss)</b>
1.5	uPVC pipes & fittings for gravity applications	AS/NZS 1254:2000	Rubber ring Generally not accepted in carriageways	Lateral connections	Iplex (licence # 1697) Marley (licence # 2365) Keyplas (licence # 2622) RX Plastics

	Category/Material	Standard	Comment	Application	Manufacturer
1.6	Polyethylene Pipe (PE) for gravity applications (minimum SN16)	AS/NZS 5056	Pipes shall be butt welded in accordance with the manufacturer's recommendations, & the standard coloured black with inner core colour white/grey or brown. Electro fusion couplings are not generally accepted.	Specific design situations	Iplex (licence # 1697) Marley (licence # 2365) RX Plastics
1.7	Corrugated aluminium or galvanized steel pipe		Not generally accepted for urban design	Specific design situations	Aluflow
<b>2</b>	<b>Fittings</b>				
2.1	PE Fittings	AS/NZS 4129,4130,4131			Dura fuse (licence #SA12420 & 2573) Iplex/Plasson Marley- Pushlok (licence #1494) Plassom (Licence #1494 & 1271)
<b>3</b>	<b>Manholes</b>				
3.1	1050 to 2500 mm ID with precast external bases/internal bases are not generally accepted	NZS 3107:1978 NZS 3109:1997 NZS 3114:1987	All manholes are to be <i>installed in accordance with this code</i>		Humes (Licence # 2618) Hynds (Licence # 2586)
3.2	Concrete lid (flat top) with 600mm openings	AS/NZS 1260 NZS 3107:1978	In carriage ways, driveways, vehicle entrances and in all other areas which could be subject to vehicle loading, Heavy duty type shall be used. In other areas medium duty type may be used	1050mm to 2500mm manholes, if bigger it will be to an engineers design	Humes (Licence # 2618) Hynds (Licence # 2586)
3.3	600mm access chambers for depth not exceeding 1.2m	NZS 3107:1978 NZS 3109:1997 NZS 3114:1987	All manholes are to be <i>installed in accordance with this code</i>	uPVC & Concrete	Humes (Licence # 2618) Hynds (Licence # 2586)
3.4	Marker pegs	M14 specifications	Offset from stormwater manholes allowing identification A <b>Green</b> disc will be attached to the marker peg identifying stormwater		RTL

	Category/Material	Standard	Comment	Application	Manufacturer
3.5	Manhole Steps 316 grade stainless steel safety step	AS/NZS 4158 AS/NZS 4020	Stainless Steel steps to be used in installation of all new manholes		Humes (Licence # 2618) Hynds (Licence # 2586)
3.6	Plastic encapsulated stainless steel safety step	AS/NZS 1657:1992 AS 4198:1994	Only to be used in cases of safety step replacement inside existing manholes		<u>Safety Step Irons</u> (Company Name) Humes Hynds
3.7	Cast iron manhole covers and frames: 600mm	BS EN 124 vehicle loading or AS3996- 80kn loading	Heavy Duty Light Duty		Humes (Licence # 2618) Hynds (Licence # 2586)
3.8	Ductile iron manhole covers and frames	Grade 500.7 ISO 1083EN124 Class D 400ISO 9001 QAS	Clear opening 600mm Non Rock	To be used in urban streets with high volume traffic and all State Highways	PAMSBRIO
3.9	Manhole sealant	BM 100 or SM9020	Adheres to adjacent surfaces under sustained compression		Sika Humes (Licence # 2618) Hynds (Licence # 2586)
<b>4</b>	<b>Sumps</b>				
4.1	Cast iron sump covers	BS EN 124 vehicle loading or AS3996- 80kn loading	Heavy Duty		Humes (Licence # 2618) Hynds (Licence # 2586)
4.2	Mega pit	Designed for HN:HO:72 loading	Capture of very high flow storm water	Specific design situations	Hynds (licence # 2586)
4.3	600mm concrete chambers	NZS 3107:1978 NZS 3109:1997 NZS 3114:1987			Humes (Licence # 2618) Hynds (Licence # 2586)

	Category/Material	Standard	Comment	Application	Manufacturer
5	<b>Stormwater management Products</b>				
5.1	Ultra drain guard		Filter system that fits in a sump Removes hydro carbons, dirt, sand and other contaminants		Ultra Tech
5.2	Ultra pipe sock		Control the flow of sediment and oil when pumping ground water		Ultra Tech
5.3	X-Tex		Durable long lasting geo-textile and filter media Absorbs hydro carbons including petroleum, animal and vegetable oils		Ultra Tech
5.4	Ultra spill berm plus		Helps contain or divert larger volume spills Flexible polyurethane construction which is non absorbent and chemical resistant		Ultra Tech
5.5	Ultra drain seals		Stops spills from going down the drain. Flexible polyurethane construction which is non absorbent and chemical resistant Will seal of most drains		Ultra Tech
5.6	Plastic fish for stormwater sumps		Blue plastic fish to be put on SW sumps showing all SW for rain only		Eco blue fish
6	<b>Fittings</b>				
6.1	uPVC	AS/NZS 1260:2002			Iplex (licence # 2365) Marley (licence # P20184) Keyplas licence # 2622)
6.2	Rubber Sleeves	AS/NZS 4326:1995	Pipe clamps to be 316 Stainless Steel		Ferco
7	<b>Pipe liners</b>				
7.1	NUFLOW		Trench less Technology	Installed by Vid-Pro	Nuflow (Vid-Pro)
7.2	AM Liner Sideliner pipe hardlining Sideliner structural pipe repair		Trench less Technology	Installed by Pipe Technology	Pipe Technology

	Category/Material	Standard	Comment	Application	Manufacturer
8	<b>Inlet/Outlet</b>				
8.1	Wing wall	NZS 3107:1978 NZS 3109:1997 NZS 3114:1987	Concrete	Specific design situations	Humes (Licence # 2618) Hynds (Licence # 2586)
8.2	Scruffy dome		Hot dipped galvanised steel	Specific design situations	

DRAFT FOR CONSULTATION

**WATER APPROVED PRODUCTS NEW PLYMOUTH DISTRICT COUNCIL****September 2010**

Notes: All parts of the Water reticulation system shall be designed using components and materials that comply with AS/NZS Standards

	Category/Material	Standard	Comment	Application	Manufacturer
<b>1</b>	<b>Fire Hydrant</b>				
1.1	Fire Hydrant	NZS/BS 750:1984 AS/NZS 4158:1996	Tall pattern screw down standard, with approved polyurethane cup washer to NZS/BS 750:1984. Pure PTFE gland packing or "O" ring sealing system and coated to AS/NZS 4158:1996 & amendments. To be rated PN 16 or higher. <b>Frost plugs with approval only - concrete block required. Squat and Medium hydrants to be used only if prior approval given.</b>		Crevet – Hydravalve Gillies Humes AVK Series 29 Hydrant Tyco F502
<b>2</b>	<b>Valves</b>				
2.1	Resilient Seated (50mm and above)	NZS/AS 2638.2:2003 AS/NZS 4158:1996 AS 4087	Resilient Seated – manufactured to NZS/AS 2638.2:2003, anti-clockwise closing with Teflon gland packing or 2 or more "O" ring seals and dust cover. External and internal protective coating to AS/NZS 4158:1996 & amendments. Rated at PN 16. Flanges to be raised face and drilled to AS 4087.		AVK valves (Licence SAI # 2420 & 2573) Crevet Ltd. Norcast (Licence # 1327) Hawle 4060E2 and 4500E2AS Series (Licence # SMKP 20123) Gillies SF Series Tyco Figure 500 Series
2.1	Gate valves (20 to 50mm)	BS 5154:1983 AS 1628	Dezincification resistant materials or LG2 gunmetal to BS 5154:1983 or AS 1628 with Malleable (cast) iron T bar handles. PN16 or higher.		Kitz Fig AS-H (with handle retaining nut changed to DR type) (Licence #2054) Tour Andersson Series 64MT DZR brass gate valve (Licence #0772) Maxiflo A59m JY-Zas gate valve (Licence #2766)
<b>3</b>	<b>Tapping Bands</b>				
3.1	Tapping Bands	MP 52-2001	Standards Australia MP 52-2001 – 'Manual of Authorisation Procedures for Plumbing and Drainage Products', Chapter 6, Licence Specifications, Section 6.25 Specification number 025-Tapping bands.		Milnes Pty Ltd (licence # W134)



	Category/Material	Standard	Comment	Application	Manufacturer
<b>4</b>	<b>Pipes - Watermains 150, 200, 250mm diameter</b>				
4.1	Cement lined ductile iron	AS/NZS 2280:2004	PN20 & PN35 286mm with TYTON JOINT elastomeric seals and socket/spigot joints (with blue polyethylene sleeving). Manufactured to AS/NZS 2280:2004 and amendments.	External protection required in corrosive ground conditions.	Tyco Tyton Excel (Licence # SMK0883) Hynds HydroTite Humes
4.2	Cement lined spiral welded	NZS 4442:1988 AS 1579:1993	286.0mm cement lined spiral welded pipe;3.2mm wall thickness, rubber ring joints and Polyken YG111 external wrapping or "Speed Steel" with polyethylene coatings to NZS 4442:1988 or AS 1579:1993.		Steelpipe NZ Ltd.
4.3	Ductile iron	AS/NZS 2280:1995	286.0mm Class K9 ductile iron, light cement lined with Tyton joints. External protection with greensleeve. Manufactured to AS/NZS 2280:1995 and amendments.		Tubemakers, Australia (as supplied by Humes, Licence # 2029).
4.4	mPVC	AS/NZS 4765:2000	250mm Class PN12 mPVC coloured blue with compatible outside diameters to asbestos cement, ductile iron and spiral welded steel. Manufactured to AS/NZS 4765:2000 series 2.		Iplex (Licence # SMK02570) Marley Genex Blue (Licence # 2624) KeyplasMetro (Licence # 2542)
4.5	oPVC	AS/NZS 4441:2008	250mm Class PN12 oPVC coloured blue with compatible outside diameters to asbestos cement, ductile iron and spiral welded steel. Manufactured to AS/NZS 4441:2008.		Apollo PVC-o
<b>5</b>	<b>Pipes - Watermains 150 and 200mm diameter</b>				
5.1	mPVC	AS/NZS 4765:2000	Class PN12 mPVC RRJ, coloured blue with compatible outside diameters to asbestos cement, ductile iron and spiral welded steel. Manufactured to AS/NZS 4765:2000 series 2.		Iplex (Licence # SMK02570) Marley Genex Blue (Licence # 2624) KeyplasMetro (Licence # 2542)

	Category/Material	Standard	Comment	Application	Manufacturer
5.2	Cement lined spiral welded		177.3mm cement lined spiral welded pipe; 232.2mm cement lined spiral welded pipe; 3.2mm wall thickness, rubber ring joints and Polyken YG111 external wrapping or "Speed Steel" with polyethylene coatings.		Steelpipe NZ Ltd.
5.3	Cement lined ductile iron		177.3mm light cement lined manufactured ClassK9 ductile iron; 232.3mm light cement lined manufactured ClassK9 ductile iron; Tyton joints with external protection with greensleeve.		Humes – Tubemakers, Australia – Licence # 2029
5.4	Cement lined ductile iron	AS/NZS 2280:1995	TYTON EXCEL PN20 & PN35 Cement lined Ductile Iron Pipe with TYTON JOINT elastomeric seals and socket/spigot joints (with blue polyethylene sleeving). Manufactured to AS/NZS 2280:1995 and amendment.		Tyco Tyton Excel (Licence # SMK0883)
<b>6</b>	<b>Pipes - Ridermains 63mm OD</b>				
6.1	MDPE	AS/NZS 1030:1997	63mm OD MDPE PE80B, PN 12.5, SDR 11 (coloured blue or blue strip) pipe manufactured to AS/NZS 1030:1997 and amendments.		Iplex Blue Line Licence # SMK P20400 Marley Pushlok Pipe (Licence # 2639) RX Plastics (Licence # 002)
<b>7</b>	<b>Pipes - Service lines</b>				
7.1	PE	AS/NZS 4130:1997	25mm, 32mm, 63mm OD MDPE PE80B, PN 12.5, SDR 11 (coloured blue or blue strip) manufactured to AS/NZS 4130:1997 and amendments.		Iplex Blue Line Licence # SMK P20400 Marley Pushlok Pipe (Licence # 2639) RX Plastics (Licence # 002)

	Category/Material	Standard	Comment	Application	Manufacturer
7.2	Copper	NZS 3501	20mm & 25mm half hard copper tube. Manufactured to NZS3501.		Mico Wakefield Crane Enfield Metals McKechnie Metals, Auckland (Licence # 2003)
<b>8</b>	<b>Backflow Prevention Devices</b>				
8.1	Backflow Prevention Devices	AS 2845.1-1998	Devices manufactured to satisfy the NZWWA publication 'Backflow Prevention for Drinking Water Suppliers Code of Practice': - AS 2845.1-1998 'Water Supply – Backflow Prevention Devices – Materials, Design and Performance Requirements' or - ASSE Standards (Americans Society of Sanitary Engineers Standards) - Non-Testable dual check – low risk	<b>All BFP installations 50mm and above are subject to specific approval by NPDC.</b>	Wilkins 705 non-testable dual check valve (20 and 25mm) Taylors Transmark FCX Tyco Ames (except silver bullet 4000ss over 50mm) RMC
<b>9</b>	<b>Water meters</b>				
9.1	Water meters		Manufactured to OIML R49 – 'Water Meters intended for the metering of cold potable water with Class C measuring accuracy'. Suppliers listed on the Acceptable Fittings & Materials list will be contacted to assist in selecting a meter which is fit for purpose (e.g. Class B or C or combination meter)	<b>All meter installations 50mm and above are subject to specific approval by NPDC.</b>	AD Riley Ltd. Elster Kent PSM-T Class C inline water meter (20 to 40mm) Elster Kent MSM (Qn 1.5) Class C co-axial water meter Sensus 620 (20 to 40mm) Class C inline water meter Sensus 620 (Qn 1.5) Class C co-axial water meter Sensus Meijet Class C water meter (50 to 100mm) Sappel
<b>10</b>	<b>Fittings - Reticulation</b>				
10.1	Cast Iron pipe fittings	AS/NZS 1830 AS/NZS 2544:1995 AS/NZS 4158:1996	Cast iron pipe flanged, socket and spigot fittings to AS/NZS 1830 and AS/NZS 2544:1995 with flanges to Table D and coated to AS/NZS 4158:1996 and amendments. Rated at PN16 or higher.	<b>To be used only if prior approval given.</b>	Gillies

	Category/Material	Standard	Comment	Application	Manufacturer
10.2	Ductile iron pipe fittings	AS/NZS 2280:1999 AS/NZS 4158:1996	Ductile iron pipe flanged, socket and spigot fittings to AS/NZS 2280:1999 with flanges to Table D, or raised, faced and drilled to AS 4087, and coated to AS/NZS 4158:1996 and amendments.		Crevet Griptite (Licence # 943 & 950) Humes (Licence # 2029) Surecast Tyco TYTON JOINT (Licence # PRD/R61/0412/1) Gillies
10.3	Stand alone flanges	AS/NZS 4158:1996	Stand Alone Flanges to Table D PVC; Ductile iron coated to AS/NZS 4158:1996 & amendments.		Iplex- PVC Marely – PVC Uniflange Adaptor – DI (as supplied by Steel & Tube NZ) Gillies Viking Johnson Hynds Humes
10.4	Bolts/nuts/washers	AS/NZS 1111 and 1112AS/NZS 1252:1983	316 grade stainless steel with factory applied molybond coating and complying with AS 1252:1983 – High Strength Steel Fastenings.		Viking Johnson
10.5	Gibaults	AS/NZS 4158:1996	– Ductile iron coated in accordance with AS/NZS 4158:1996 & amendments and stainless steel bolts. – M16316 stainless steel, with clips fusion coated to AS/NZS4158 and 316 stainless steel fasteners.		Gillies Milnes Pty Ltd. Tyco Vari-Gib Crevet Viking Johnson
10.6	MDPE fittings				Durafuse (Licence # 9603049) Iplex – Plasson Marley – Philmac (Licence # 1271) Marley – Pushlok (Licence # 1494) Plassim (Licences # 1494 & 1271) Plastic Systems-Alprene A16 Easygrip (Licence # 1157) PPI Corporation – GF + Compression Fittings (Licence # 1157) Aguaspec
10.7	Brass fittings				McKechnie Metals Methven
10.8	Manifold				Acuflo Industries Ltd. – Acuflo GM900s 20mm manifold

## **APPENDIX B – STANDARD CONSTRUCTION DRAWINGS**

(Informative)

The following drawings are sourced with permission from the Water Services Association of Australia and modified for New Zealand conditions.

### COMMON DETAILS

CM – 001	Embedment and trenchfill – Typical arrangement
CM – 002	Standard embedment – Flexible and rigid pipes
CM – 003	Bulkheads and trenchstop – Standard details
CM – 004	Manholes – Standard details - <i>Amended</i>
CM – 005	Manholes – Drop manhole details - <i>Amended</i>
CM – 006	Manholes – Stormwater or wastewater DN 375 to DN 750

### WATER SUPPLY

WS – 001	Typical mains construction – Reticulation main arrangements
WS – 002	Typical mains construction – Distribution and transfer mains - <i>Amended</i>
WS – 003	Property services – Connection to main - <i>Amended</i>
WS – 004	Thrust blocks – Concrete block details - <i>Amended</i>
WS – 005	Thrust and anchor blocks – Gate valves and vertical bends - <i>Amended</i>
WS – 006	Valve and hydrant identification – Identification markers and marker posts

### WASTE WATER

WW – 001	Deleted
WW – 002	Property connections – Buried interface method - <i>Amended</i>

These drawings will be available in standard CAD and .pdf formats as free downloads from the Standards New Zealand webshop ([www.standards.co.nz](http://www.standards.co.nz)). Purchasers of this Standard will be able to adapt the CAD drawings for incorporation into their specific design without breaching copyright.

All dimensions are in millimetres unless otherwise stated.

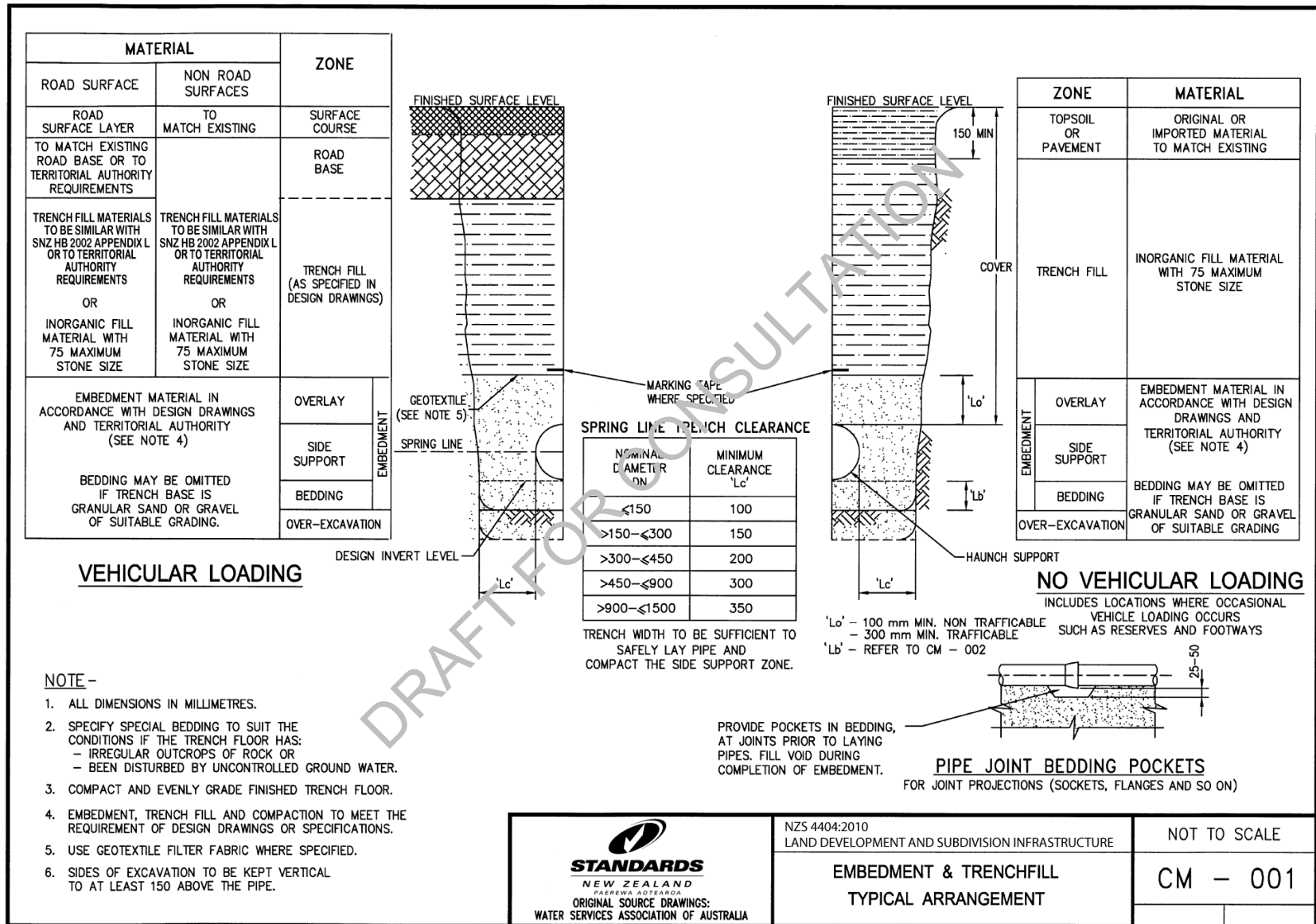

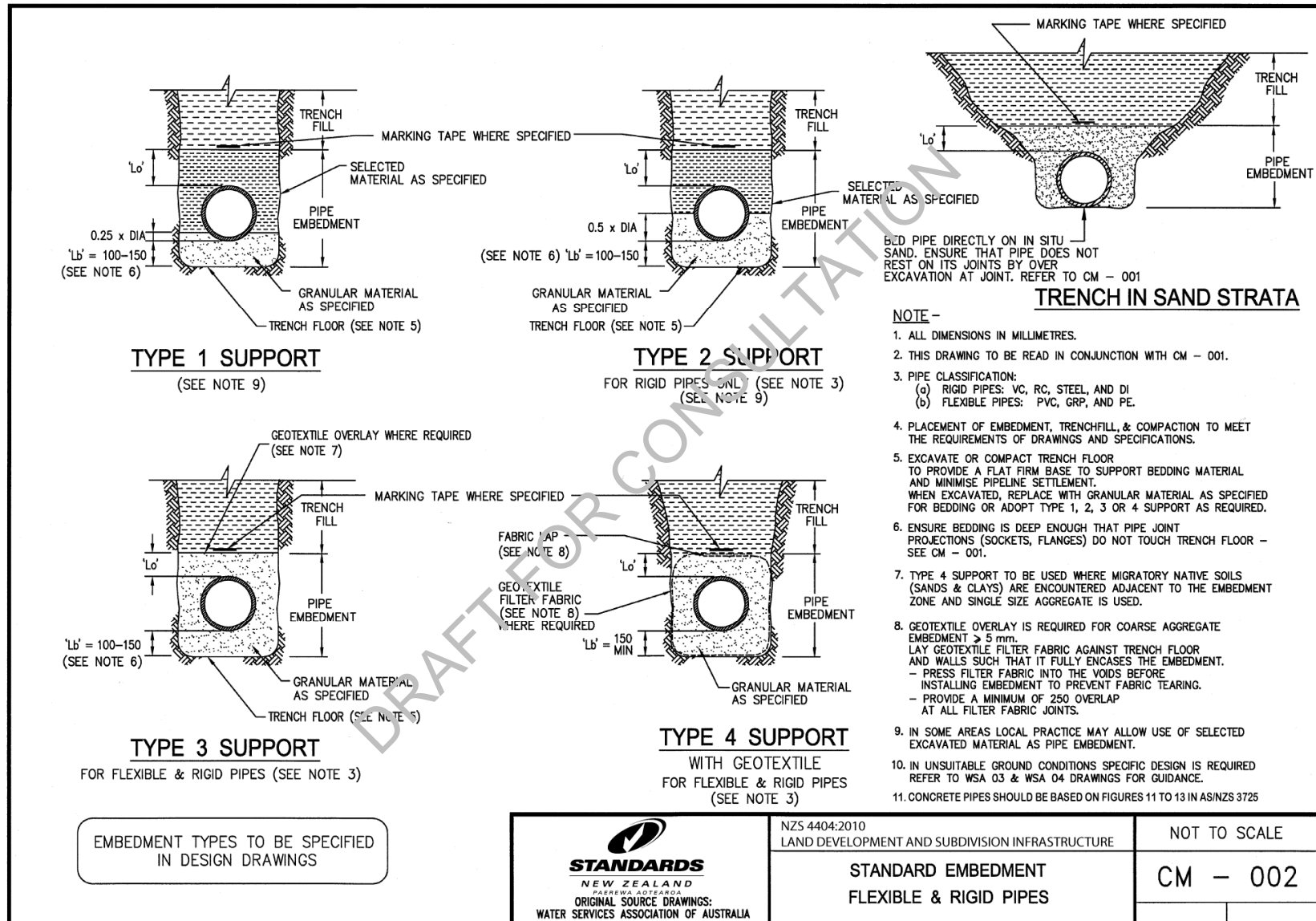

EMBEDMENT TYPES TO BE SPECIFIED IN DESIGN DRAWINGS

 <b>STANDARDS</b> NEW ZEALAND PŌREWA AOTEAROA ORIGINAL SOURCE DRAWINGS: WATER SERVICES ASSOCIATION OF AUSTRALIA	NZS 4404:2010 LAND DEVELOPMENT AND SUBDIVISION INFRASTRUCTURE	NOT TO SCALE
	STANDARD EMBEDMENT FLEXIBLE & RIGID PIPES	CM - 002

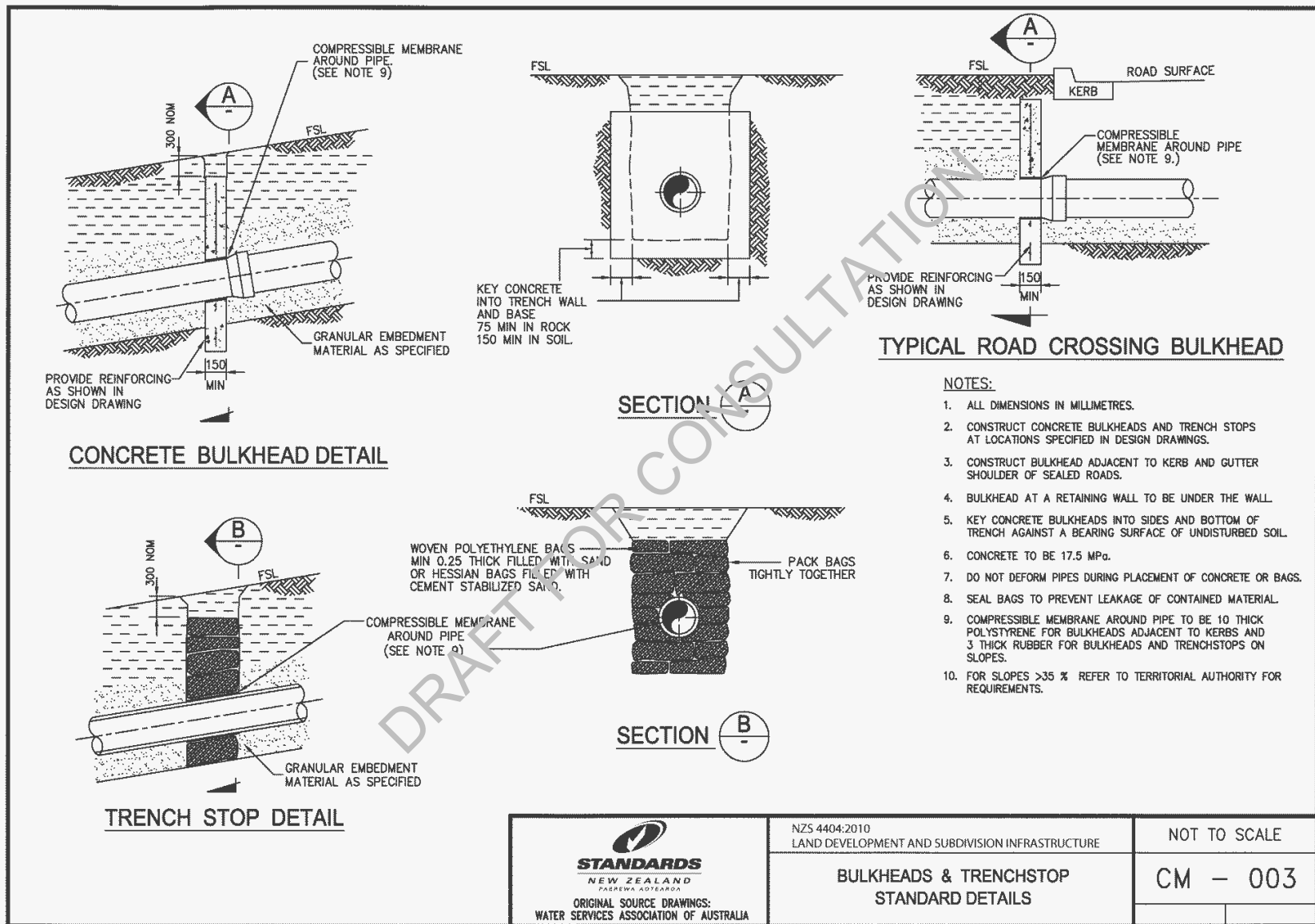

<p><b>STANDARDS</b> NEW ZEALAND PAREWA AOTEAROA</p> <p>ORIGINAL SOURCE DRAWINGS: WATER SERVICES ASSOCIATION OF AUSTRALIA</p>	<p>NZS 4404:2010 LAND DEVELOPMENT AND SUBDIVISION INFRASTRUCTURE</p>	<p>NOT TO SCALE</p>
	<p><b>BULKHEADS &amp; TRENCHSTOP STANDARD DETAILS</b></p>	<p><b>CM - 003</b></p>



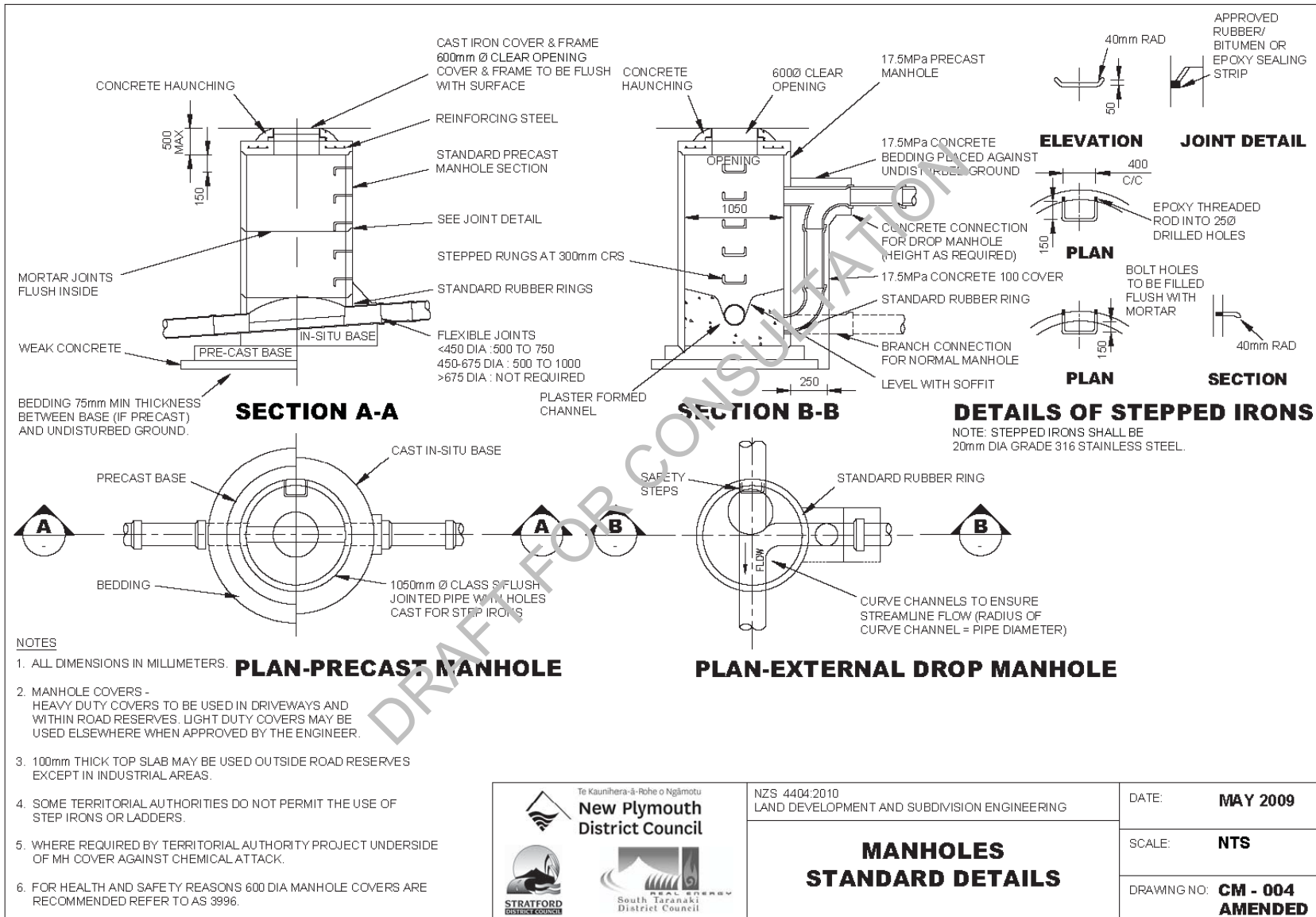

<p>Te Kaunihera-ā-Rohē o Ngāmotu <b>New Plymouth District Council</b></p> <p><b>STRATFORD</b> DISTRICT COUNCIL</p> <p><b>SOUTH TARANAKI</b> DISTRICT COUNCIL</p>	<p>NZS 4404:2010 LAND DEVELOPMENT AND SUBDIVISION ENGINEERING</p>	<p>DATE: <b>MAY 2009</b></p>	
	<p><b>MANHOLES STANDARD DETAILS</b></p>		<p>SCALE: <b>NTS</b></p>
			<p>DRAWING NO: <b>CM - 004 AMENDED</b></p>

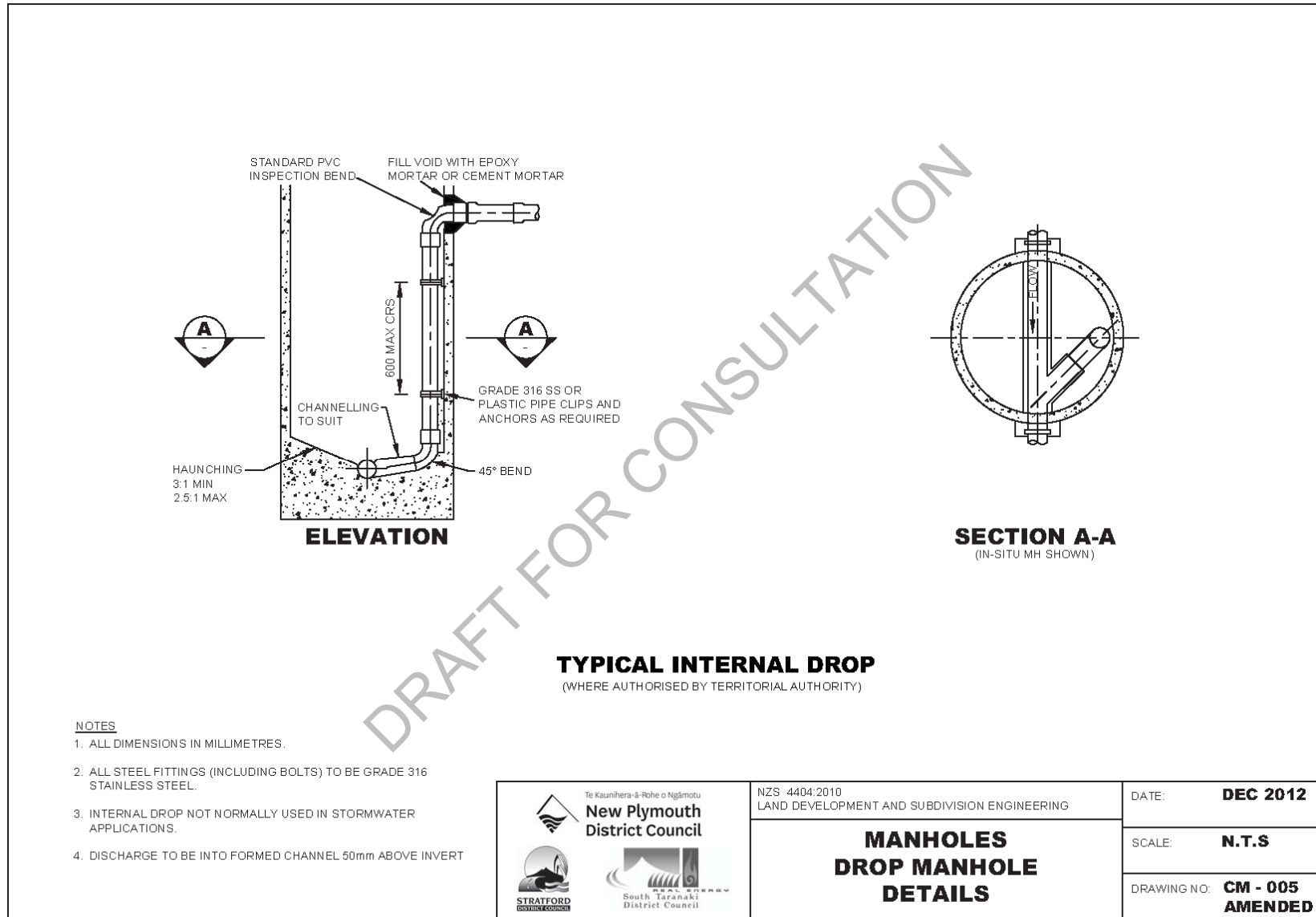

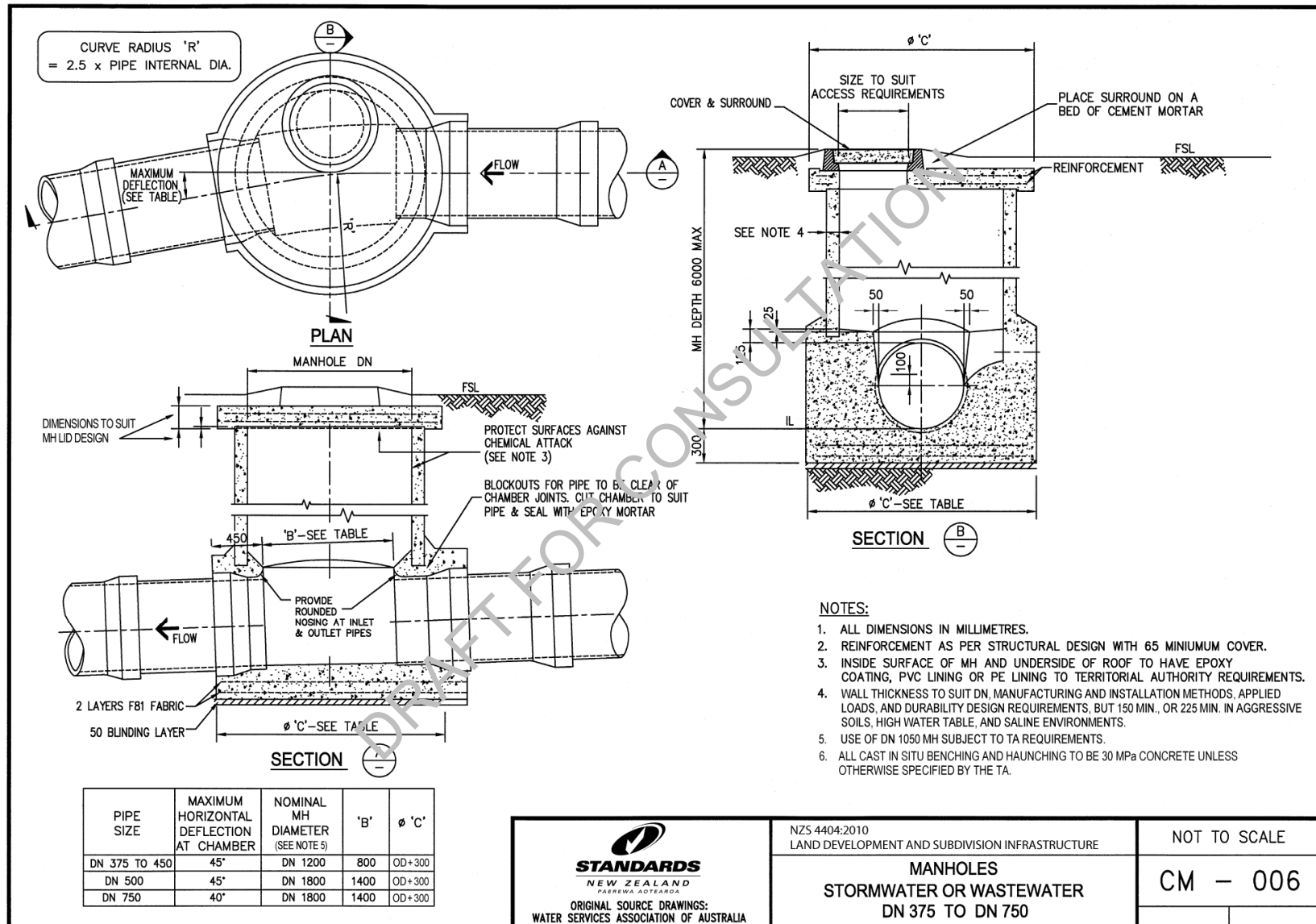

**TYPICAL INSTALLATION OF PVC & DI PIPES & FITTINGS**

**TYPICAL INSTALLATION OF PE PIPES & FITTINGS**

**TYPICAL VALVE CONNECTION DIRECT TO NEW MAIN**

**NOTE -**

1. ALL DIMENSIONS IN MILLIMETRES.
2. INSTALL PIPEWORK PARALLEL TO PROPERTY BOUNDARIES.
3. STAINLESS STEEL AND NYLON COATED (TO AS/NZS 4158) TAPPING BANDS DO NOT REQUIRE ADDITIONAL CORROSION PROTECTION.
4. WRAP BOLTED CONNECTIONS USING OTHER THAN NYLON COATED FITTINGS AND STAINLESS STEEL BOLTS WITH A PETROLATUM TAPE SYSTEM.
5. WHERE MAINS ARE 300 OR LARGER BYPASSES SHOULD BE INSTALLED FOR ALL MANUAL SLUICE VALVES.
6. ALL VALVES AND FITTINGS SHALL BE COATED WITH A THERMAL BONDED POLYMERIC COATING APPLIED IN ACCORDANCE WITH AS/NZS 4158.

**DI & PVC PIPE**

7. DUCTILE IRON FITTINGS MAY BE USED WITH DI & PVC PIPE. FITTINGS SHALL BE NYLON COATED AND LINED OR CEMENT LINED WITH A BITUMINOUS EXTERNAL COATING. DO NOT USE PVC FITTINGS WITH DI PIPE.
8. PE SLEEVING REQUIRED ON ALL BITUMINOUS COATED DI PIPE AND FITTINGS APPLIED IN ACCORDANCE WITH AS 3681. TWO THICKNESSES REQUIRED BETWEEN FITTINGS AND THRUST BLOCK. REINSTATE ANY DAMAGED SLEEVING AS PER MANUFACTURER'S SPECIFICATIONS.
9. USE PRE TAPPED CONNECTORS ON DN 100 & DN 150 NEW MAIN INSTALLATIONS (UNLESS SPECIFIED OTHERWISE BY THE TERRITORIAL AUTHORITY).
10. USE TAPPING BANDS FOR CONNECTIONS TO EXISTING MAINS AND NEW MAINS >DN 50.
11. ELECTRICALLY ISOLATE COPPER SERVICES FROM DI/CL PIPE.

**PVC PIPE**

12. TAPPING BANDS ON PVC PIPE TO BE FULL CIRCLE CLAMPING.
13. WHERE PVC FITTINGS ARE USED, A PROTECTIVE MEMBRANE IS REQUIRED BETWEEN FITTING AND THRUST BLOCK. PVC FITTINGS TO BE USED ONLY ON PVC PIPE. DI SPIGOTS NOT TO BE INSERTED INTO PVC SOCKETS.
14. MAXIMUM SIZE OF DRILLED HOLES FOR SERVICE CONNECTIONS IN PVC PIPE TO BE 30 % DN OR 50 (LOWER VALUE TO BE USED) LARGER HOLES CAN BE USED FOR UNDER PRESSURE TAPPING.

**DI PIPE**

15. DIRECT TAPPING OF >DN 200 DI/CL MAY BE AUTHORISED BY TERRITORIAL AUTHORITY.

**PE PIPE**

16. PE PIPE MAY BE COLD BENT TO MINIMUM RADIUS OF 25 x (OD). STAKES OR OTHER SOURCES OF POINT LOADS SHALL NOT BE USED TO ASSIST IN BENDING THE PIPE.
17. MAKE ALLOWANCE DURING CONSTRUCTION FOR EXPANSION AND CONTRACTION OF PE PIPE DUE TO TEMPERATURE CHANGES.
18. BUTT WELDING IN ACCORDANCE WITH WSA-01 (POLYETHYLENE CODE). BUTT WELDING IN TRENCHES IS NOT PERMITTED.
19. ALL MECHANICAL COUPLINGS TO BE SELF-RESTRAINING.

<p><b>STANDARDS</b> NEW ZEALAND PAERUA AOTEAROA</p> <p>ORIGINAL SOURCE DRAWINGS: WATER SERVICES ASSOCIATION OF AUSTRALIA</p>	<p>NZS 4404:2010 LAND DEVELOPMENT AND SUBDIVISION INFRASTRUCTURE</p>	<p>NOT TO SCALE</p>
	<p>TYPICAL MAINS CONSTRUCTION RETICULATION MAIN ARRANGEMENTS</p>	<p>WS - 001</p>

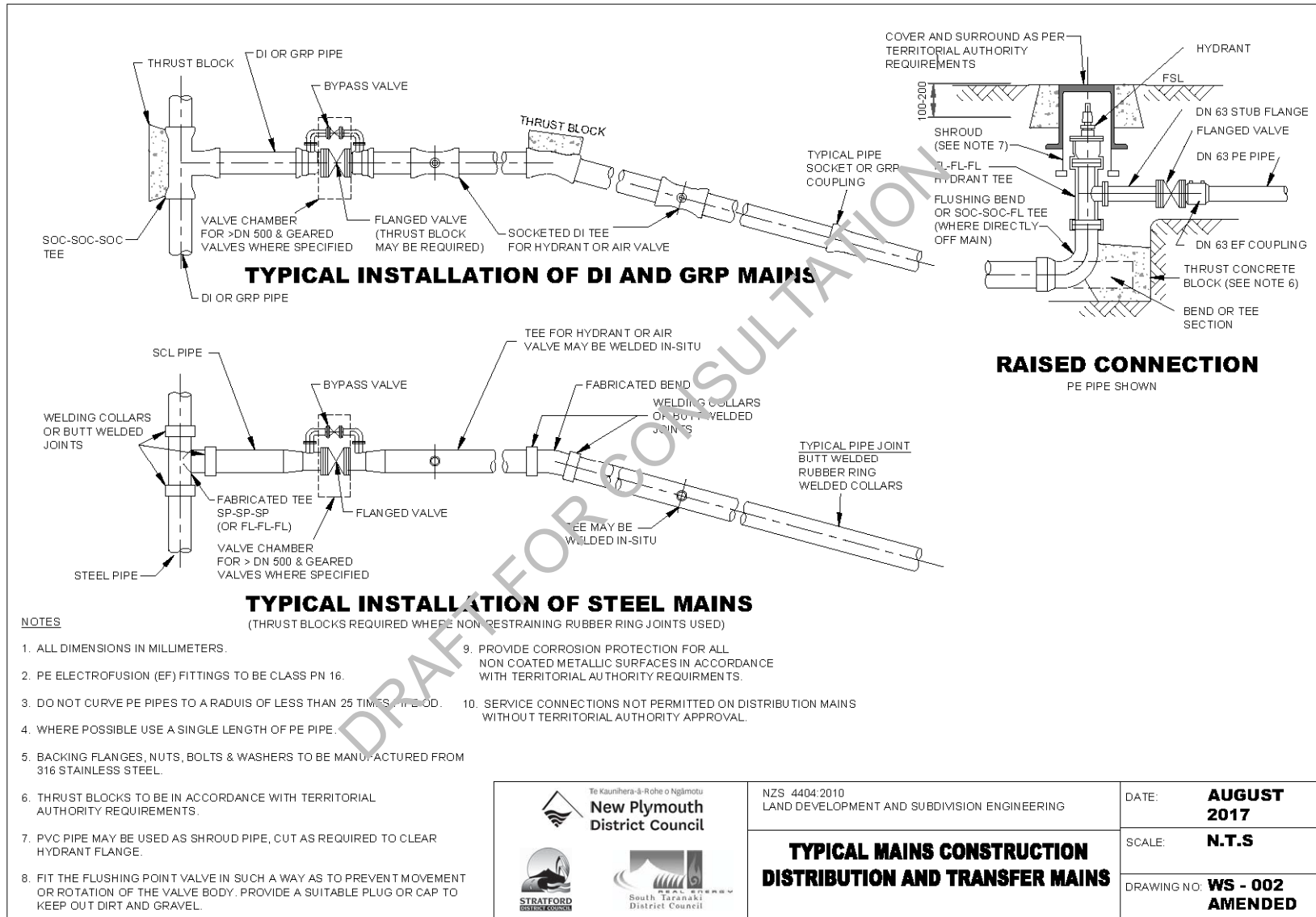

	NZS 4404:2010 LAND DEVELOPMENT AND SUBDIVISION ENGINEERING	DATE: <b>AUGUST 2017</b>
		SCALE: <b>N.T.S</b>
		DRAWING NO: <b>WS - 002 AMENDED</b>

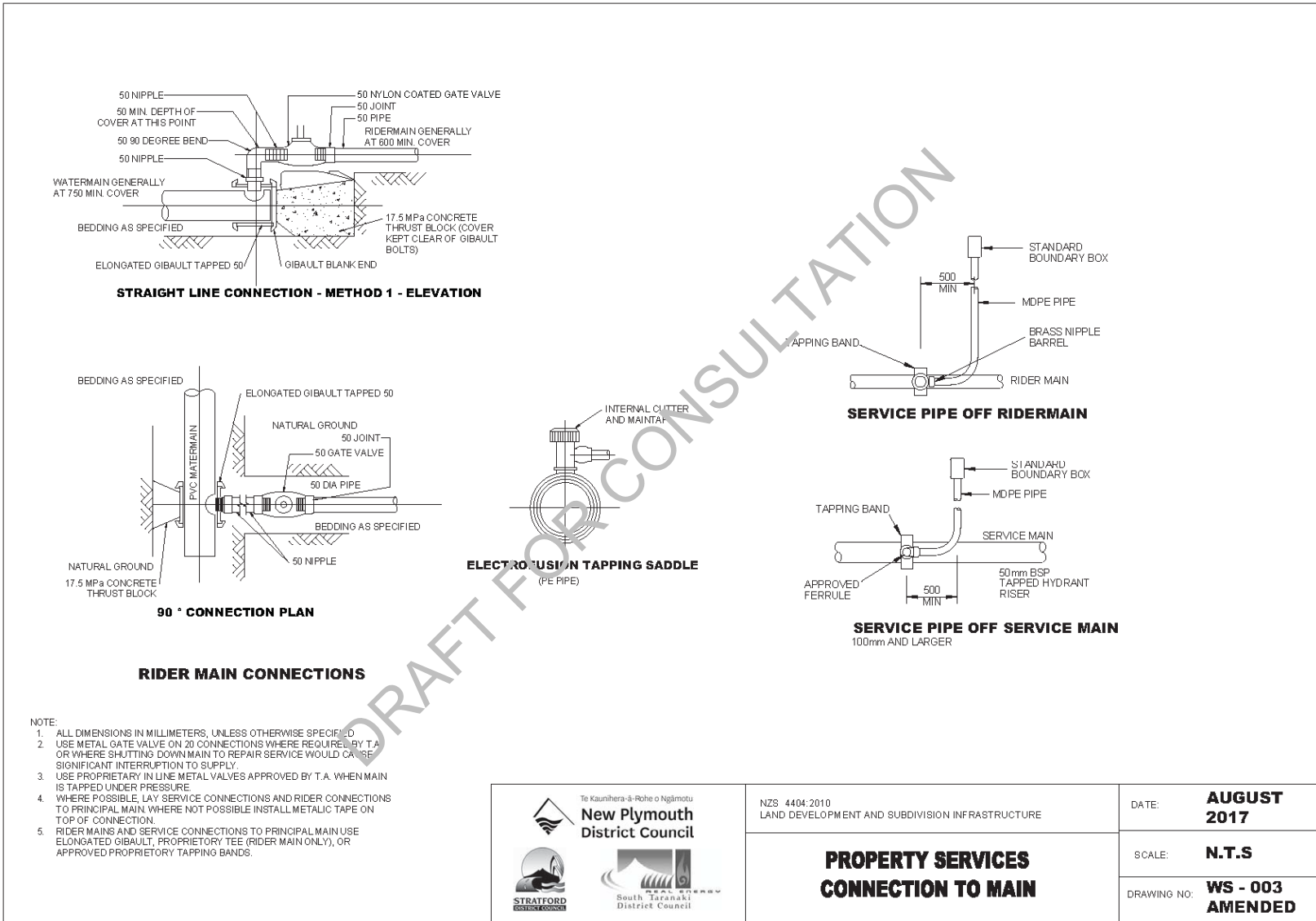

Te Kaitiaki-a-Rohe o Ngāmotu  
**New Plymouth District Council**

STRATFORD DISTRICT COUNCIL  
 South Taranaki District Council

NZS 4404:2010  
 LAND DEVELOPMENT AND SUBDIVISION INFRASTRUCTURE

**PROPERTY SERVICES CONNECTION TO MAIN**

DATE:	<b>AUGUST 2017</b>
SCALE:	<b>N.T.S</b>
DRAWING NO.:	<b>WS - 003 AMENDED</b>

### THRUST BLOCKS DESIGN

BASED ON SAFE BEARING LOAD OF 50kPA

DIA NOM. (DN)	BEARING AREA (m <sup>2</sup> ) FOR HORIZONTAL ANCHORS					CONCRETE VOLUMES & BEARING AREAS FOR VERTICAL ANCHORS							
	BEND ANGLES					BEND ANGLES							
	90	60	45	22.5	11.25	60		45		22.5		11.25	
	T. End, Hyd					cu.m	sq.m	cu.m	sq.m	cu.m	sq.m	cu.m	sq.m
100	0.34	0.24	0.18	0.09	0.05	0.43	0.12	0.35	0.07	0.19	0.02	0.10	0.00
150	0.70	0.50	0.38	0.19	0.10	0.89	0.25	0.73	0.15	0.39	0.04	0.20	0.01
200	1.20	0.85	0.65	0.33	0.17	1.53	0.43	1.25	0.25	0.68	0.06	0.35	0.02
225	1.51	1.07	0.82	0.42	0.21	1.93	0.53	1.57	0.31	0.85	0.08	0.43	0.02
250	1.81	1.28	0.98	0.50	0.25	2.31	0.64	1.88	0.37	1.02	0.10	0.52	0.02
300	2.67	1.89	1.44	0.74	0.37	3.40	0.94	2.78	0.55	1.50	0.14	0.77	0.04
375	4.04	2.85	2.18	1.11	0.56	5.15	1.43	4.20	0.84	2.27	0.22	1.16	0.05
400	5.71	4.04	3.09	1.58	0.79	7.29	2.02	5.95	1.18	3.22	0.31	1.64	0.08
450	6.99	4.94	3.78	1.93	0.97	8.92	2.47	7.28	1.45	3.94	0.38	2.01	0.09
525	9.90	7.00	5.36	2.73	1.37	12.63	3.50	10.31	2.05	5.58	0.53	2.84	0.13
675	15.18	10.74	8.22	4.19	2.10	19.37	5.37	15.81	3.14	8.56	0.82	4.36	0.21

**NOTES:**

- ALL DIMENSIONS IN MILLIMETRES UNLESS OTHERWISE SPECIFIED.
- CAST THE THRUST AREA OF ALL THRUST BLOCKS AGAINST A CLEAN FACE OF UNDISTURBED NATURAL SOIL. THRUST BLOCKS NOT TO INTERFERE WITH OTHER SERVICES.
- DO NOT USE STANDARD THRUST BLOCKS AS SPECIFIED IN THIS DRAWING IN:
  - VERY SOFT, SOFT OR FIRM CLAY.
  - LOOSE CLEAN SAND.
  - UNCOMPACTED FILL OR REFUSE.
 A GEOTECHNICAL ASSESSMENT AND INDIVIDUAL DESIGN IS REQUIRED FOR THESE SOILS.
- THE NOMINAL THRUST AREA TO BE ACHIEVED BY POURING CONCRETE THE FULL LENGTH OF THE FITTING AND EXTENDING FROM THE FLOOR OF THE TRENCH TO ABOVE THE FITTING (SEE ALSO NOTE 7).
- DESIGN PRESSURES OTHER THAN 1000 KPA REDUCE OR INCREASE THE MINIMUM THRUST AREA BY THE RATIO OF THE DESIGN PRESSURES EXCEPT WHERE:
  - MIN THRUST AREA IS <0.1 m<sup>2</sup>
- FINISH THRUST BLOCKS APPROXIMATELY 100 ABOVE THE TOP OF THE FITTING OR BEARING PAD AND EXTEND TO THE FLOOR OF THE TRENCH OR DEEPER IF NECESSARY TO ACHIEVE THE REQUIRED THRUST AREA, MAXIMUM ENCASEMENT TO BE 180.
- THE MINIMUM THRUST AREA FOR TAPER THRUST BLOCKS TO BE EQUAL TO THE DIFFERENCE BETWEEN THE THRUST AREAS FOR DEAD ENDS OF EQUIVALENT DIAMETER TO THOSE EACH SIDE OF TAPER.
- FOR DOWNWARD VERTICAL THRUST, THE ALLOWABLE BEARING PRESSURES FOR VARIOUS SOILS MAY BE TAKEN AS TWICE THAT FOR HORIZONTAL THRUST SHOWN.
- WHEN POURING CONCRETE AGAINST FITTINGS PLACE A MEMBRANE OF POLYETHYLENE, PVC OR FELT BETWEEN THE FITTING AND CONCRETE TO PREVENT DAMAGE TO THE FITTING. JOINTS TO BE CLEAR OF CONCRETE.
- CONCRETE TO BE KEPT CLEAR OF BOLTS & FLANGES OR GIBALT JOINTS TO ALLOW FITTINGS TO BE REMOVED WITHOUT INTERFERING WITH ANCHOR BLOCK.

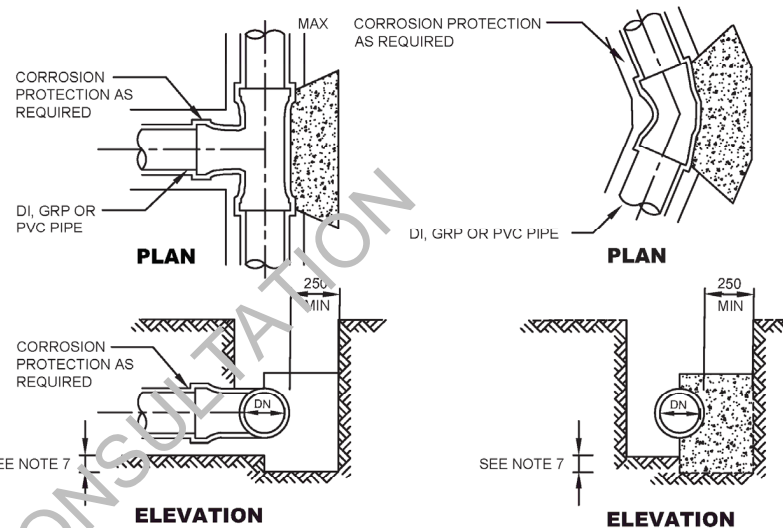

**THRUST BLOCK FOR TEES THRUST BLOCK FOR BENDS**  
(FOR HORIZONTAL THRUST)

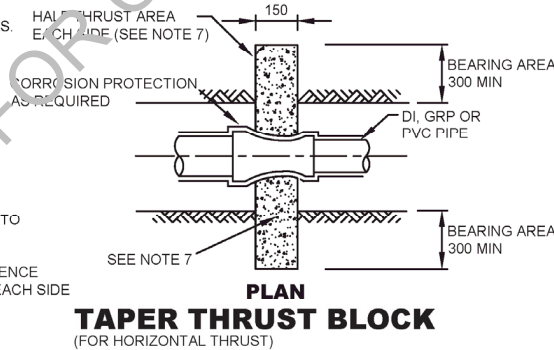

**TAPER THRUST BLOCK**  
(FOR HORIZONTAL THRUST)

	NZS 4404:2010 LAND DEVELOPMENT AND SUBDIVISION ENGINEERING	DATE: <b>MAY 2009</b>
	<p align="center"><b>THRUST BLOCKS CONCRETE BLOCK DETAILS</b></p>	SCALE: <b>NTS</b>
		DRAWING NO: <b>WS - 004 AMENDED</b>

**FLANGED VALVES**

**VERTICAL BENDS**

**SOCKETED VALVES**

**TYPICAL SS STRAP**

**NOTES**

1. ALL DIMENSIONS IN MILLIMETRES UNLESS OTHERWISE SHOWN.
2. ANCHOR BLOCKS IN THE TABLE ARE DESIGN FOR A TEST PRESSURE OF 1000 kPa (100 m HEAD). ADJUST CONCRETE VOLUME TO SUIT ACTUAL TEST PRESSURE.
3. WHERE DI PIPES AND FITTINGS WITH RESTRAINED JOINTS ARE USED THRUST BLOCKS ARE NOT PERMITTED..
4. THRUST BLOCK REINFORCEMENT AS SPECIFIED IN DESIGN DRAWINGS.
5. WHERE SPECIFIED PROVIDE CONCRETE THRUST BLOCKS FOR S0C-S0C VALVES. THRUST AREA TO BE AS FOR DEAD ENDS AS SHOWN IN WS - 004 AMENDED.
6. INSTALL PUDDLE FLANGES ON CLASS K12 DI CL PIPE.

**ANCHOR BLOCK CONSTRUCTION NOTES:**

- LOCATE ANCHOR BLOCK CENTRALLY AROUND BEND.
- KEY ANCHOR BLOCK INTO BASE OF TRENCH A MINIMUM DEPTH OF 250.
- POUR CONCRETE AGAINST A SOLID EXCAVATION FACE.
- USE GRADE 17.5 Mpa CONCRETE.
- KEEP CONCRETE CLEAR OF ALL BOLTS, NUTS AND PIPE JOINTS.

	<p>Ti Kaurihera-i-Rohie o Ngāmotu <b>New Plymouth District Council</b></p> <p>South Taranaki District Council</p>	<p>NZS 4404:2010 LAND DEVELOPMENT AND SUBDIVISION ENGINEERING</p>	<p>DATE: <b>MAY 2009</b></p>
<p><b>THRUST AND ANCHOR BLOCKS GATE VALVES AND VERTICAL BENDS</b></p>			<p>SCALE: <b>N.T.S</b></p>
			<p>DRAWING NO: <b>WS - 005 AMENDED</b></p>



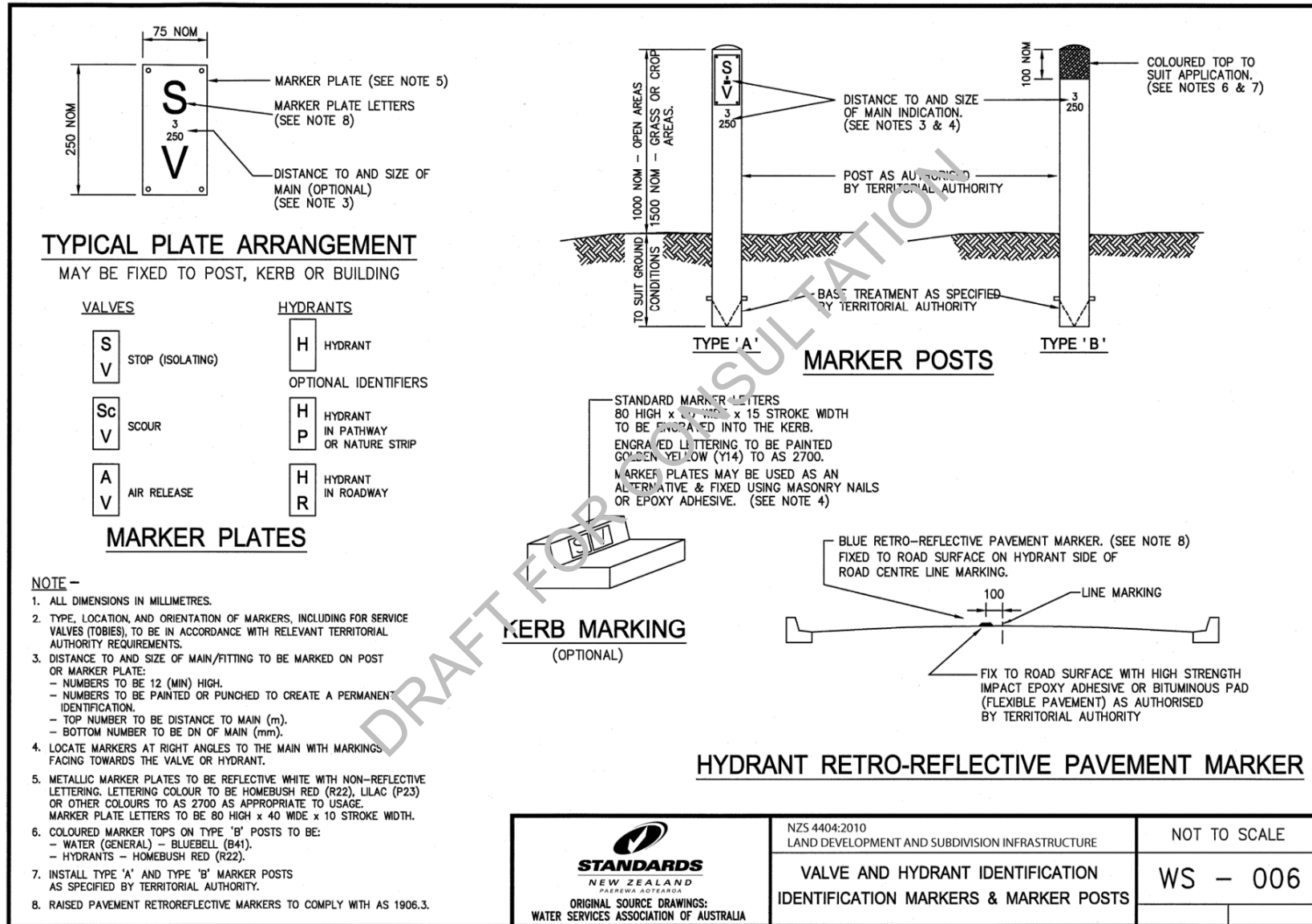

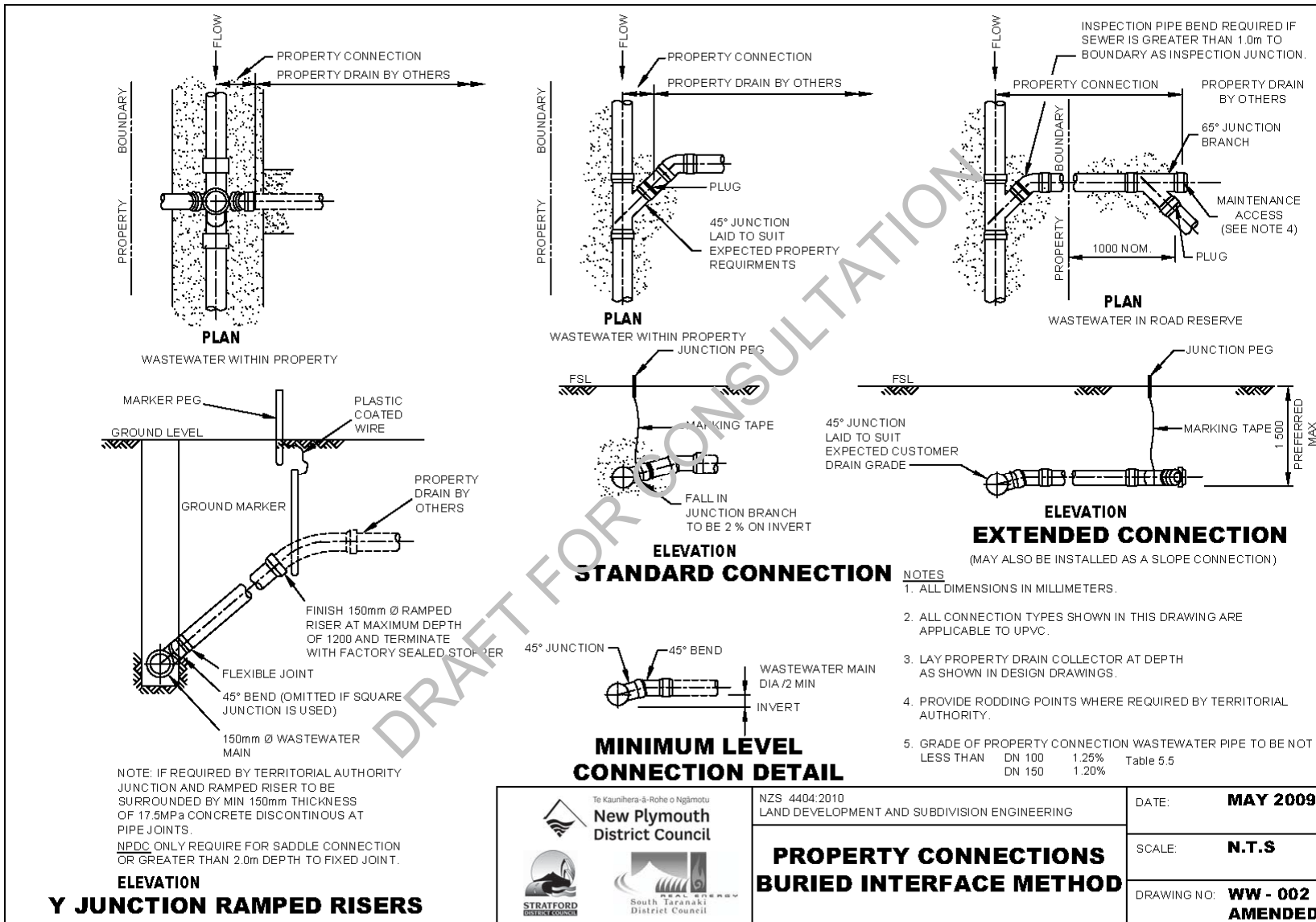

Property connections generally 1200 deep at boundary (900min-1500max) and in accordance with clause 5.3.10 unless approved by the TA

**NOTES**

DRAFT FOR CONSULTATION

DRAFT FOR CONSULTATION

## **APPENDIX C – FIELD TESTING OF PIPELINES**

(Normative)

### **C1 Scope**

Appendix C is based on some of the test methods in AS/NZS 2566.2, section 6, and associated appendices. This appendix specifies suggested methods of test and their application to field testing of pipelines for the purpose of determining pipeline acceptability. Field testing includes leak or hydrostatic pressure testing, as appropriate, for pressure and non-pressure pipelines. Testing may also be carried out in accordance with the material-specific and application-specific test methods of AS/NZS 2032, AS/NZS 2033, and AS/NZS 2566.2.

#### **C1.1 Purpose of field testing**

The purpose of field testing is to:

- (a) Reveal the occurrence of faults in the laying procedure, for example, joints incorrectly installed or pipes damaged;
- (b) Reveal the occurrence of faults in the assembly procedure of pipeline components, for example, tapping bands, maintenance structures, frames, and covers;
- (c) In the case of pressure pipelines, determine that the pipeline will sustain a pressure greater than its design pressure without leakage;
- (d) In the case of non-pressure pipelines, determine that the pipeline satisfies the requirements for infiltration and exfiltration; and
- (e) Test the installed structural integrity of the pipeline.

Field testing is not intended to supplement or replace the test requirements of product standards.

### **C2 Non-pressure pipelines – Field leakage testing**

Leakage testing is used to reveal locations of potential infiltration and exfiltration due to the inclusion of damaged pipes, seals, or incorrectly made joints in the pipeline at the completion of installation.

Leakage testing for acceptance of non-pressure pipelines shall be carried out by at least one of the following methods:

- (a) Low pressure air testing;
- (b) Hydrostatic testing

NOTE – Air tests provide qualitative data only, as air pressure losses cannot be related directly to water leakage rates.

For pipeline test sections installed below the water table, and for submarine pipelines, the test pressure used for the hydrostatic test, and for the air test, shall be increased to maintain the required differential between internal and external pressure.

A pipeline failing to meet the requirements of the air tests may be retested using the hydrostatic test method.

NOTE – Failure is still probable.

**C2.1 Low pressure air test**

The test length shall be acceptable where the gauged pressure exceeds 18 kPa (or not more than 7 kPa less than the pressure at the start of the test) for the time interval shown in Table C1 after the shut-off of the air supply.

Table C1 is based on an air test pressure of 25 kPa (in excess of any external hydrostatic pressure due to groundwater) and, on this basis, air volume losses shall not exceed the greater of:

- (a) A rate of 0.0009 m<sup>3</sup>/(min x m<sup>2</sup>) of pipe wall area; and
- (b) A rate of 0.056 m<sup>3</sup>/min, which is regarded as the lowest detectable individual air leak.

Column 2 and column 3 of Table C1 give the times and lengths up to which (b) prevails over (a).

NOTE – For safety reasons air test pressures in excess of 50 kPa should not be applied.

DRAFT FOR CONSULTATION

**Table C1 – Low pressure air and vacuum tests – Minimum time intervals for 7 kPa pressure change in pipeline**

DN	Minimum time (minutes)	Maximum length for minimum time to apply (metres)	Test length (metres)				
			50	100	150	200	250
			Minimum test duration (minutes)				
80	1.5	231	1.5	1.5	1.5	1.5	1.6
100	2	185	2	2	2	2	3
150	3	123	3	3	3	5	6
225	4	82	4	5	8	10	13
300	6	62	6	9	14	18	23
375	7	49	7	14	22	29	36
450	9	41	10	21	31	41	52
525	10	35	14	28	42	56	70
600	11	31	18	37	55	73	92
675	13	27	23	46	70	93	116
750	14	25	29	57	86	115	143
900	17	21	41	83	124	165	207
1000	19	19	51	102	153	204	255
1050	20	18.8	56	112	169	225	281
1200	23	15	73	147	220	294	367
1500	28	12	115	230	344	459	574

**NOTES –**  
 The time interval may be reduced for a proportionate reduction in the allowable pressure drop. Where there is no detectable change in pressure after 1 hour of testing, the section under test shall be deemed acceptable.  
 This table is based on the following equation:  

$$T = 1.02D_1kLq$$
 where  
 $T$  = time for a 7 kPa pressure drop, in seconds  
 $D_1$  = pipeline internal diameter, in metres  
 $q$  = allowable volume loss in cubic metre/minute/square metre taken as 0.0009 m<sup>3</sup>/min.m<sup>2</sup>  
 $k = 0.054DL$  but not less than 1  
 $L$  = length of test section, in metres.  
 Columns 2 and 3 have been calculated with  $k = 1.0$ .  
 The appropriate air or vacuum test/pressure method for pipes larger than DN 750 should be established by reference to the specifier.

**C2.1.1 Low pressure air test procedure**

The procedure shall be as follows:

- (a) Pump in air slowly until a pressure of 25 +5, -0 kPa is reached. Where the pipeline is below the water table this pressure shall be increased to achieve a differential pressure of 25 kPa. In no circumstances should the actual pressure exceed 50 kPa;

NOTE – Rapid pressurisation may cause significant air temperature changes, which will affect the testing accuracy.

- (b) Maintain the pressure for at least 3.0 minutes;
- (c) Where no leaks are detected, shut off the air supply;
- (d) Where the pipeline fails the test, repressurise to 25 +5,-0 kPa and check for leaks by pouring a concentrated solution of soft soap and water over accessible joints and fittings;
- (e) Repair any defects, then repeat steps (a) to (c);
- (f) With the air supply shut off, monitor the pressure for the time intervals given in Table C1.

The test length shall be acceptable where the pressure drops by 7 kPa, or less, over the required (tabulated) test period.

NOTES –

- (1) The test length of pipeline should be restricted to pipeline sections between maintenance holes (the most convenient places for inserting test plugs or fixing temporary bulkheads). The method should not be used for test lengths in excess of 250 m and for pipe diameters larger than 1500 mm.
- (2) The procedure for low pressure air testing of large diameter pipelines is potentially hazardous because of the very large forces to be resisted by temporary plugs or bulkheads and the serious consequences of accidental bulkhead blow-out. A relief valve, with a 50 kPa maximum setting, should be installed on all pressurising equipment.

## **C2.2 Hydrostatic test**

The test length shall be acceptable where the specified allowable make up water is not exceeded. Where not specified, the allowable make up water shall be 0.5 L/hour per metre length per metre diameter.

### **C2.2.1 Hydrostatic test procedure**

The procedure shall be as follows:

- (a) The test pressure shall be not less than 20 kPa, or 20 kPa above the groundwater pressure at the pipe soffit at its highest point, whichever is the greater, and not exceed 60 kPa at the lowest point of the section;
- (b) Steeply graded pipelines shall be tested in stages where the maximum pressure, as stated above, will be exceeded if the whole section is tested in one length;
- (c) The pressure shall be maintained for at least 2 hours by adding measured volumes of water where necessary;
- (d) Any visible leaks detected shall be repaired and the pipeline shall be retested.

## **C3 Pressure pipelines**

### **C3a Pressure Pipe Test Method 1**

#### **General**

*All pipelines shall be subject to initial testing by the Contractor prior to backfilling around or over the pipe. Tests shall be carried out in the presence of the Engineer who shall be given 24 hours notice of any test.*

*The tests shall be carried out at the Contractor's expense. All testing equipment and labour shall be supplied by the Contractor, who shall be satisfied that the pipes will sustain a test before calling on the Engineer to observe it.*



**Timing**

Testing of each section of the reticulation shall take place in the presence of the Engineer and the Engineer Manager prior to the covering of the pipe joints and backfilling. All anchor and thrust blocks must be in place. Joints are to be dry prior to the test. Testing shall not be carried out during wet weather.

**Equipment**

All necessary equipment and apparatus including pressure gauges shall be provided by and set up by the Contractor prior to the commencement of the test. All pressure gauges shall have been calibrated and certified by a Telarc registered laboratory not more than six months before the test.

**Test Pressure**

Unless otherwise stated in the job specification, the section under test shall withstand a pressure of 1.5 times the pressure rating of the pipe at the lowest point on that section of pipeline, or 1400 kPa whichever is the lesser.

**Procedure (Service Mains)**

The test procedure shall be according to Section 9.3 of NZS 7643: 1979 Code of Practice for the Installation of Unplasticised PVC Pipe Systems. Procedure B only shall apply.

**Procedure (MDPE Rider Mains)**

The following procedure shall be followed for the testing of MDPE rider mains:

1. Apply the test pressure for a duration of 30 minutes.
2. Check for any obvious leaks.
3. After 30 minutes reduce the test pressure rapidly by bleeding water from the system to a pressure of 20 kPa at the test gauge.
4. Close the valve to isolate the system being tested.
5. Record pressure readings at 5 minute intervals for a further 30 minutes.

If the pressure does not rise, or falls after an initial rise, then the test has **failed**. If the pressure rises and maintains pressure or continues to rise, then the test will be deemed to have **passed**.

**Final Testing**

After backfilling and before the final connection to the existing reticulation is made, a similar test may be required.

**C3b Pressure Pipe Test Method 2 - Field Hydrostatic Pressure Testing**

The hydrostatic pressure test method shall be as specified.

Hydrostatic pressure testing requires selecting an appropriate configuration of method, pressure, and length of test section.

Test parameters and details shall be determined with due consideration to the following:

- (a) Pipe material;
- (b) Pipe diameter;
- (c) Length of test section;
- (d) Duration of the test;
- (e) Magnitude of test pressure and rate of pressurisation;
- (f) Presence of air in the pipeline;
- (g) Time required for saturation of porous liners;
- (h) Potential movement of pipeline thrust restraints;
- (i) Design pressure for thrust and anchor supports;

- (j) Accuracy of test equipment;
- (k) Ambient temperature changes during testing;
- (l) Presence of leaks in equipment used for testing or equipment attachment points (such as sealing plugs);
- (m) Potential for leaks in the pipeline.

NOTE – It is advisable to begin testing early in the pipeline installation to confirm adequacy of laying procedures and, where appropriate, to increase the length tested progressively as experience is gained.

### **C3.1 Selection of test pressure**

The hydrostatic test pressure at any point in the pipeline shall be:

- (a) Not less than the design pressure; and
- (b) Not more than 25% above the rated pressure of any pipeline component.

NOTE – The design pressure is the maximum system pressure at a point in the pipeline, considering future developments, static pressure, dynamic pressure, and an allowance for short-term surge pressure (water hammer), as determined by analysis.

Compressed air testing shall not be permitted for pressure pipe.

### **C3.2 Selecting test lengths**

The pipeline length tested shall be either the whole, or a section (capable of being isolated), of the pipeline depending on the length and diameter, the availability of water, and the spacing between sectioning valves or blank ends.

The pipeline shall be divided into test sections such that:

- (a) The hydrostatic test pressure at any point in the pipeline is:
  - (i) Not less than the design pressure; and
  - (ii) Not more than 25% above the rated pressure of any pipeline component; and
- (b) Water is available for the test together with facilities for its disposal, in accordance with regulatory requirements, after the test.

NOTE –

- (1) Pipelines longer than 1000 m may need to be tested in several sections. Where long lengths are to be tested, radio or other electronic means of communication between test operatives, to coordinate test procedures and thus minimise the test duration, is desirable.
- (2) Long test sections may incorporate a large number of mechanical (that is, flanged) joints, which should be checked for leakage. The longer the test section the harder it is to locate a leak, or discriminate between a leak and the other effects, such as the absorption of air into solution under pressure.

### **C3.3 Pre-test procedures**

The pre-test procedures are as follows:

- (a) All required temporary and permanent thrust blocks, or other pipeline thrust-resisting methods, including integral joint-restraint systems, shall be in place, and all concrete shall be adequately cured (normally a minimum of 7 days);
- (b) Blank flanges or caps shall be installed at the beginning and end of the test section. Testing shall not take place against closed valves unless they are fully restrained and it is possible to check for leakage past the valve seat. Mechanical ends that are not end load resistant shall be temporarily strutted or anchored, to withstand the test pressures without movement;

NOTE – Temporary supports should not be removed until the pipeline has been depressurised. All test personnel should be informed of the loading limits on temporary fittings and supports.

- (c) Where practicable, all bolted joints shall be left exposed to allow for re-tensioning during or after testing;
- (d) Compacted embedment and fill material shall be placed to leave all joints, service connections and ball valves exposed wherever possible;
- (e) For PE pipelines, the pressurising time shall not exceed 45 minutes;

NOTE – The pressurising time affects the duration of the PE pipeline test.

- (f) The test equipment shall be placed in position and checked for satisfactory operation;
- (g) The pump shall be of adequate size to raise and maintain the test pressure;

NOTE – A pump that is too small may increase the test duration or where too large it may be difficult to control the pressure.

- (h) Two calibrated test gauges shall be used to cross check gauge accuracy;
- (i) Slowly fill the test length of pipeline with water, preferably from the lowest point, ensuring air is vented at the high point valves. Allow a period, in the range of 3 hours to 24 hours, for the temperature of the test length and the test water to stabilise and for dissolved air to exit the system. The recommended rate of filling shall be based on a flow velocity of 0.05 m/s, calculated from the following equation:

$$Q_f \leq 12.5\pi D^2$$

where

$Q_f$  = filling rate, in litres per second

$D$  = pipe diameter, in metres

NOTE – The slow rate of 0.05 m/s avoids air entrainment when the filling water is cascading through downward gradients along the pipeline.

The period of stabilisation will depend on pipe dimensions, length, material, longitudinal profile, and air exit points. For cement-mortar lined pipe, the pipeline shall be filled at least 24 hours before the commencement of the test, to allow the lining to become saturated.

NOTE – A firm foam swab may be used ahead of the fill water to assist air removal especially where the pipeline undulates. Extract the swab at a high-point wash-out.

Typical pressure test equipment and location are shown in Figures C1 and C2.

#### **C3.4 Post-test procedures**

After testing, pipelines shall be depressurised slowly. All air venting facilities shall be open when emptying pipelines. The test water shall be drained to an approved waterway and all connection points shall be reinstated.

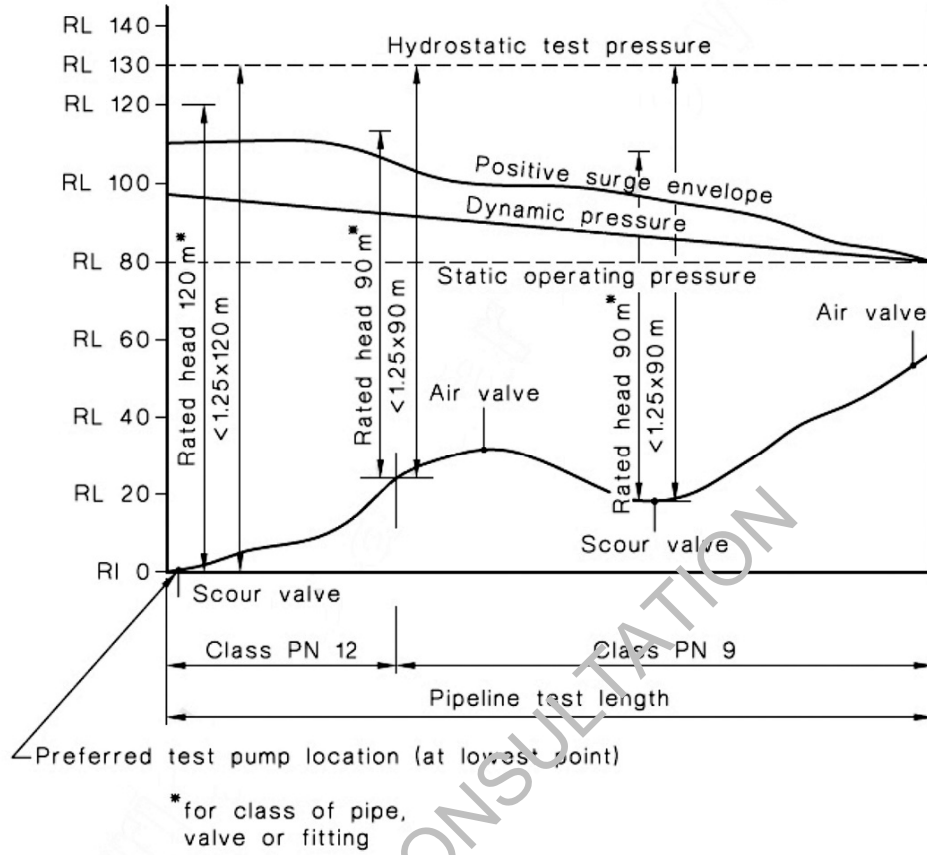

NOT TO SCALE

Figure C1 – Typical pressure profile under field hydrostatic test

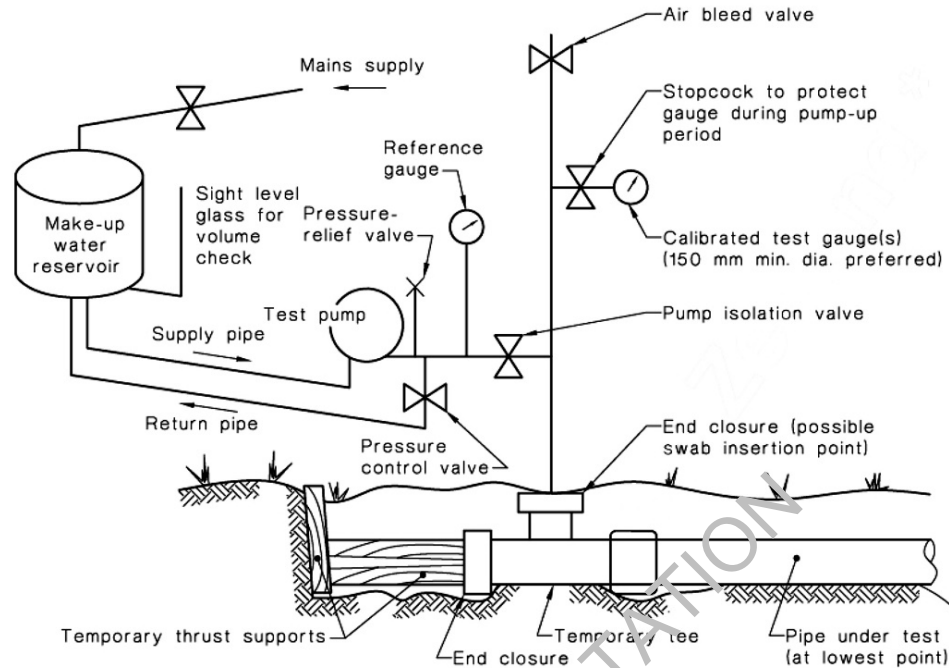

Figure C2 – Typical field pressure test equipment layout

**C3.5 Constant pressure test (water loss method) – PVC, DI, GRP, and steel pipelines**

This test is applicable for PVC, DI, GRP, and steel pipelines. The test length may be several kilometres in length (see C3.2).

**C3.5.1 Procedure**

The procedure shall be as follows:

- (a) Close all valves apart from the test pump input and pressurise the test length to the specified test pressure (STP) (see C3.1);
- (b) Apply and then maintain the test pressure by the addition of measured and recorded quantities of make-up water at regular intervals over a period, in the range of 1 hour to 12 hours;
- (c) Where pressure measurements are not made at the lowest part of the test length, make an allowance for the static head, between the lowest point of the pipeline and the point of measurement, to ensure that the test pressure is not exceeded at the lowest point.

The quantity of make-up water necessary to maintain the test pressure shall comply with the following equation:

$$Q \leq 0.14LDH$$

where

Q = allowable make-up water, in litres per hour

L = length of the test length, in kilometres

D = nominal diameter of the test length, in metres

H = average test head over length of pipeline under test, in metres

NOTE – The make-up water is not a leakage allowance, but is an allowance to cover the effects of the test head forcing small quantities of entrapped air into solution. Normally the test should last for a minimum of 2 hours and be concluded within 5 to 8 hours. The make-up water requirement should reduce with time as air goes into solution. Where, after 12 hours the make-up water still exceeds the allowable limit, testing should cease and the cause of loss investigated.

**C3.5.2 Acceptance**

- (a) The test length shall be acceptable where there is no failure of any thrust block, pipe, fitting, joint, or any other pipeline component;
- (b) There is no physical leakage;
- (c) The quantity of make-up water necessary to maintain the test pressure complies with C3.5.1.

**C3.6 Constant pressure test (water loss method) for viscoelastic pressure pipelines**

This test is applicable to PE, PP, and ABS pressure pipelines. The test lengths may be several kilometres in length.

NOTE – This method is based on VAV P78, as outlined in AS/NZS 2566.2, Appendix A.

**C3.6.1 Procedure**

The procedure shall be as follows:

- (a) Purge the air from pipeline;
- (b) Apply the specified test pressure (STP) (see C3.1) to the test length;
- (c) Shut off main and allow pressure to settle for 12 hours (pressure will drop significantly);
- (d) Re-apply and maintain test pressure for 5 hours by successively pumping a sufficient amount of water;
- (e) Measure and record water volume (V1 in litres) required to maintain this pressure between Hour 2 and Hour 3;
- (f) Measure and record water volume (V2 in litres) required to maintain this pressure between Hour 4 and Hour 5;
- (g) Calculate:  

$$0.55V1 + Q$$

where Q is the allowable make-up volume obtained from C3.5.1.

**C3.6.2 Acceptance**

The test length shall be acceptable where:

- (a) The test length shall be acceptable where there is no failure of any thrust block, pipe, fitting, joint, or any other pipeline component;
- (b) There is no physical leakage; and
- (c)  $V2 \leq 0.55 V1 + Q$ .

**C3.7 Pressure rebound method for viscoelastic pressure pipelines**

This test is applicable to PE, PP, and ABS pressure pipelines up to and including DN 315, where a short test time is required.

NOTE – This test is based on BS EN 805:2000, Appendix A (refer to AS/NZS 2566.2).

**C3.7.1 Pressure measurement rig**

The test rig shall be a recently calibrated pressure transducer, data logger, and check pressure gauge that has a dial of at least 100 mm diameter and a pressure range that places the specified test pressure (STP) (see C3.1) in the range 35% to 70% of the gauge's full scale. The transducer and the check gauge shall read within  $\pm 5\%$  of each other. If they do not agree within this tolerance, the equipment shall be recalibrated or replaced.

**C3.7.2 Procedure**

The test procedure has the following three phases:

- (a) A preliminary phase in which the pipeline is —
  - (i) Depressurised and allowed to relax after the C3.3 pre-test procedure
  - (ii) Pressurised quickly to the test pressure and maintained at this pressure for a period of time without further water being added
  - (iii) The pressure is allowed to decay by viscoelastic creep, and
  - (iv) Provided the pressure drop does not exceed a specified maximum, the pressure test can proceed to the second phase;
- (b) A phase in which the volume of air remaining in the pipeline is assessed against an allowable maximum;
- (c) The main test phase in which the pipeline is maintained at the test pressure for a period of time and decay due to viscoelastic creep commenced. The creep is interrupted by a rapid reduction of the pressure in the pipeline to a specified level. This rapid reduction in pressure results in contraction of the pipeline with an increase (rebound) in pressure. If, during the rebound period, the pressure versus time record shows a fall in pressure, the pipeline fails the test.

**C3.7.3 Preliminary phase**

The procedure shall be as follows:

- (a) Reduce pressure to just above atmospheric at the highest point of the test length, and let stand for 60 minutes. Ensure no air enters the line;
- (b) Raise the pressure smoothly to STP in less than 10 minutes. Hold the pressure at STP for 30 minutes by pumping continuously, or at short intervals as needed. Do not exceed STP;
- (c) Inspect for leaks during the 30 minute period, then shut off pressure;
- (d) Allow the pressure to decay for 60 minutes;
- (e) Measure the pressure remaining at 60 minutes (P60);
- (f) If  $P60 \leq 70\%$  of STP the test is failed. The cause shall be located and rectified. Steps (a) to (e) shall be repeated. If  $P60 > 70\%$  of STP, proceed to the air volume assessment.

**C3.7.4 Air volume assessment**

The procedure shall be as follows:

- (a) Quickly (<5 min) reduce pressure by  $\Delta P$  (10%–15% of STP);
- (b) Measure water volume bled out ( $\Delta V$ );
- (c) Calculate  $\Delta V_{\max}$  allowable as follows:

$$\Delta V_{\max} \text{ allowable} = 1.2 \times V \times \Delta P / (EW + D/ER)$$

where

1.2	=	air allowance
V	=	pipe volume, in litres
$\Delta P$	=	measured pressure drop, in kilopascals
D	=	pipe internal diameter, in metres

ER = pipe material modulus, in kilopascals (see Table C2)

EW = bulk modulus of water, in kilopascals (see Table C3);

- (d) If  $\Delta V > \Delta V_{\text{max}}$  allowable the test has failed. The cause shall be located and rectified. The preliminary phase shall be repeated. If  $\Delta V \leq \Delta V_{\text{max}}$  allowable, proceed to the main test phase.

NOTE –  $\Delta V$  and  $\Delta P$  should be measured as accurately as possible, especially where the test length volume is small.

### C3.7.5 Main test phase

Observe and record the pressure rise for 30 minutes.

In the event of failure, locate and repair leaks. If failure is marginal or doubtful, or if it is necessary to determine leakage rate, use a reference test (see C3.6).

NOTE – Figure C3 gives an example of a full pressure test with the main test phase extended to 90 minutes.

**Table C2 - Pipe E material modulus for PE 80B and PE 100**

Temp (°C)	PE 80B – E Modulus (kPa×10 <sup>3</sup> )			PE 100 – E Modulus (kPa×10 <sup>3</sup> )		
	1 h	2 h	3 h	1 h	2 h	3 h
5	740	700	680	990	930	900
10	670	630	610	900	850	820
15	600	570	550	820	780	750
20	550	520	510	750	710	680
25	510	490	470	690	650	630
30	470	450	430	640	610	600

**Table C3 - Bulk modulus, E<sub>w</sub> - Water**

Temperature (°C)	Bulk Modulus (kPa×10 <sup>3</sup> )
5	2080
10	2110
15	2140
20	2170
25	2210
30	2230



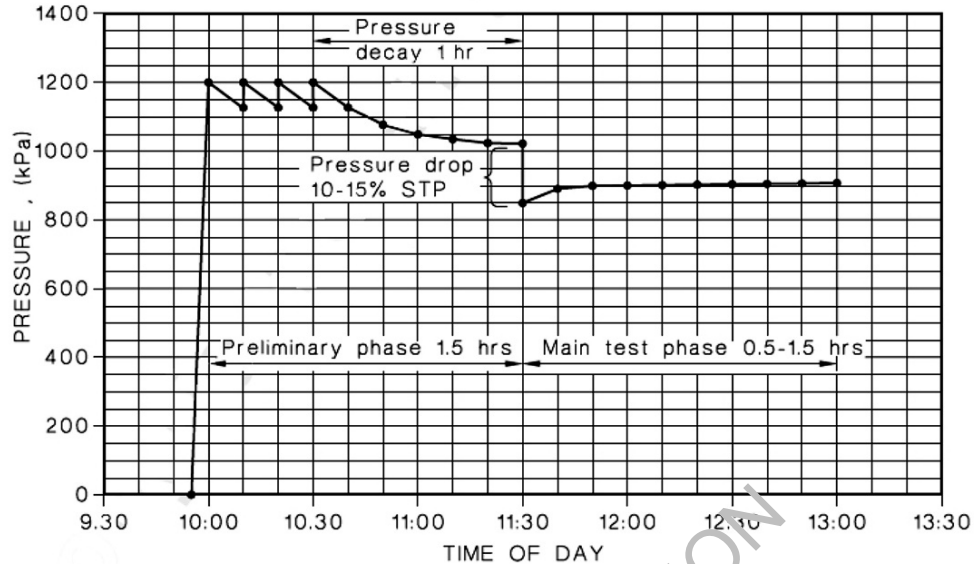

Figure C3 - Typical successful modified rebound test for a PE pipeline

### C3.7.6 Acceptance

The test length shall be acceptable if:

- There is no failure of any thrust block, pipe, fitting, joint, or any other pipeline component;
- There is no physical leakage;
- The pressure rises or remains static in the 30-minute period.

If doubt exists about the pressure recovery, the monitoring period may be increased to 90 minutes, and any pressure drop that does occur shall not exceed 20 kPa over the 90-minute period.

If the pressure drops by more than 20 kPa during the 90-minute extended period, the test fails.

Repetition of the main test phase shall only be done by carrying out the whole test procedure, including the relaxation period of 60 minutes described in C3.7.3.

### C3.8 Visual test for small pressure pipelines

This test is applicable for small pipelines of all materials (less than 200 m in length), and pipelines where pipeline joints have been left exposed for the test operation (such as coiled pipe).

#### C3.8.1 Procedure

The procedure shall be as follows:

- The test pressure (see C3.1) shall be applied and the test section isolated by closing the high point air release valves and the pump feed valve;
- The test section shall be visually inspected for leakage at all joints, especially bolted joints, all fittings, service connections, and ball valves;
- Pressure gauges shall be checked to ensure that pressure has not fallen significantly indicating an undetected leak;
- Any detected leak shall be repaired and the section shall be retested;
- Where no leak is detected, high point air release valves shall be opened, the pipeline shall be depressurised to slowly drain the line into an approved waterway and all connection points shall be reinstated.

**C3.8.2 Acceptance**

The test length shall be acceptable where:

- (a) There is no failure of any thrust block, pipe, fitting, joint, or any other pipeline component;
- (b) There is no physical leakage; and
- (c) There is no pressure loss indicative of a leak.

**C4 Manhole Test**

Manholes shall be tested by filling manhole and measuring water drop over 30 minutes. The water drop after 30 minutes shall be less than or equal to the allowable water level drop in Table C4.

**Table C4 Allowable water level drop (mm)**

Measurement Diameter (mm)	Manhole Depth (m)							
	1	2	3	4	5	6	7	8
300	14.9	29.7	44.6	59.4	74.3	89.1	104.0	118.8
350	10.9	21.8	32.7	43.7	54.6	65.5	76.4	87.3
400	8.4	16.7	25.1	33.4	41.8	50.1	58.5	66.8
450	6.6	13.2	19.8	26.4	33.0	39.6	46.2	52.8
500	5.3	10.7	16.0	21.4	26.7	32.1	37.4	42.8
550	4.4	8.8	13.3	17.7	22.1	26.5	30.9	35.4
600	3.7	7.4	11.1	14.9	18.6	22.3	26.0	29.7
650	3.2	6.3	9.5	12.7	15.8	19.0	22.1	25.3
700	2.7	5.5	8.2	10.9	13.6	16.4	19.1	21.8
750	2.4	4.8	7.1	9.5	11.9	14.3	16.6	19.0
800	2.1	4.2	6.3	8.4	10.4	12.5	14.6	16.7
850	1.9	3.7	5.6	7.4	9.3	11.1	13.0	14.8
900	1.7	3.3	5.0	6.6	8.3	9.9	11.6	13.2
950	1.5	3.0	4.4	5.9	7.4	8.9	10.4	11.9
1000	1.3	2.7	4.0	5.3	6.7	8.0	9.4	10.7
1050	1.2	2.4	3.6	4.9	6.1	7.3	8.5	9.7
1100	1.1	2.2	3.3	4.4	5.5	6.6	7.7	8.8
1150	1.0	2.0	3.0	4.0	5.1	6.1	7.1	8.1
1200	0.9	1.9	2.8	3.7	4.6	5.6	6.5	7.4
1250	0.9	1.7	2.6	3.4	4.3	5.1	6.0	6.8
1300	0.8	1.6	2.4	3.2	4.0	4.7	5.5	6.3
1350	0.7	1.5	2.2	2.9	3.7	4.4	5.1	5.9
1400	0.7	1.4	2.0	2.7	3.4	4.1	4.8	5.5
1450	0.6	1.3	1.9	2.5	3.2	3.8	4.5	5.1
1500	0.6	1.2	1.8	2.4	3.0	3.6	4.2	4.8
1550	0.6	1.1	1.7	2.2	2.8	3.3	3.9	4.5
1600	0.5	1.0	1.6	2.1	2.6	3.1	3.7	4.2
1650	0.5	1.0	1.5	2.0	2.5	2.9	3.4	3.9
1700	0.5	0.9	1.4	1.9	2.3	2.8	3.2	3.7
1750	0.4	0.9	1.3	1.7	2.2	2.6	3.1	3.5
1800	0.4	0.8	1.2	1.7	2.1	2.5	2.9	3.3

## **APPENDIX D1 – WATER SUPPLY DISINFECTION SPECIFICATION FOR NEW PIPELINES**

(Normative)

### **D1 Disinfection of pipelines and fittings**

After flushing the main to remove all debris and air, the main shall be filled with water containing a free available chlorine concentration of  $15 \text{ g/m}^3 \pm 5 \text{ g/m}^3$  and allowed to stand for a minimum of 12 hours for all new mains. At the end of the disinfection period, the free available chlorine (FAC) concentration shall be at least  $5 \text{ g/m}^3$ . If the FAC is less than  $5 \text{ g/m}^3$  at the completion of the period, the disinfection shall be repeated until a satisfactory result is obtained. Note that the main should not be drained after flushing unless all high points are 'vented' to allow for complete removal of air.

Under no circumstances will the use of handfuls of hypochlorite powder or chlorine tablets dumped into the pipe and hydrant tees be an acceptable practice.

The sterilising solution should be fed by gravity or pumped into one end of the main and the 'flushing' water in the pipe displaced out of the opposite end of the main until tests carried out show that the water being displaced contains the full FAC concentration. The authorised officer will arrange for testing of the FAC concentration and, to this end, the contractor shall give 24-hours notice of intention to sterilise.

The contractor shall provide all temporary fittings necessary to allow for the introduction of the sterilising solution to and its removal from the main.

See also D3.

### **D2 Methods of introducing the sterilising solution**

Methods of introducing sterilising solution will depend on the volume of solution required for the particular main and the availability of appropriate equipment.

In general, wherever the pipe volume is less than  $10 \text{ m}^3$ , the most practical method is to add sufficient calcium or sodium hypochlorite (powder or solution) to a potable water tanker suitable for carrying potable water to achieve the desired  $15 \text{ g/m}^3$  FAC concentration. (This may require two tankers full.)

For greater quantities, the sterilising solution may be injected into the main using a portable gas chlorinator or a hypochlorinator. An approved backflow preventer shall be installed if either of these options is used.

### **D3 Disposal of sterilising solution**

After the satisfactory completion of the sterilising process, the chlorine solution shall be flushed into the sanitary wastewater pipe or, alternatively, retained in a temporary surface storage pond until the TA's authorised officer is satisfied that the FAC has reduced to a satisfactory concentration before being allowed to flow down the stormwater drainage system or into a natural watercourse.

### **D4 Acceptable method for sterilising mains**

- (a) Use sodium hypochlorite solution. This solution usually has 10% or 15% FAC;
- (b) Obtain a clean water tanker, as used for potable drinking water. The tanker should have a known water capacity;
- (c) Measure the required amount of sodium hypochlorite solution into a beaker and pour it into the empty tanker;

NOTE – The final strength of the chlorine to water is to be  $15 \text{ g/m}^3 \pm 5 \text{ g/m}^3$ .

- (d) Fill the tanker to the appropriate volume and ensure the solution is well mixed;

- (e) Charge the new main with the chlorinated water from the tanker at one end of the main or into a new hydrant through a standpipe. All service pipes and hydrants shall be left open and allowed to run for a couple of minutes. The services and hydrants shall then be closed to allow the highest end of the main to fill completely;

NOTE – The main should ideally be charged from the highest point. This will allow the water to be gravity fed into the main. If this is not possible the water tanker shall have a truck mounted pump to pump the chlorinated water in.

- (f) Seal off the main and leave it charged with the chlorinated water for 24 hours;
- (g) Take samples and test for residual chlorine;
- (h) After 24 hours flush the main well until the chlorine smell is gone. Once the main is connected into the reticulation system it should be flushed thoroughly before the services are connected up.

NOTE – For large mains, a water tanker may not have the required capacity so a dose pump system shall be used and approved by the authorised officer.

Example:

- A. Calculate the volume of the mains to be chlorinated, that is, 85 m of 100 mm dia. Main

$$\text{Vol.} = \frac{85 \times \pi \times 0.1^2}{4} = 0.67 \text{ m}^3$$

$$= 667.6 \text{ litres}$$

Plus 110 m of 150 mm dia. main

$$\text{Vol.} = \frac{110 \times \pi \times 0.15^2}{4} = 1.944 \text{ m}^3$$

$$= 1,944 \text{ litres}$$

$$\text{Total volume} = 1,944 + 667.6 = 2,611.6 \text{ litres}$$

- B. The total volume of 2,611.6 litres is less than the volume of the water tanker (say 5,000 litres) so calculate how many millilitres of sodium hypochlorite is required for the 5,000 litre tanker to give a final solution of 15 g/m<sup>3</sup>.

$$V = \frac{V \times c}{s \times 10}$$

v = volume of sodium hypochlorite in ml

V = volume of water tanker

c = concentration of final solution in g/m<sup>3</sup>

s = strength of concentrated hypochlorite in % FAC

$$v = \frac{5000 \times 15}{15 \times 10} = 500 \text{ ml}$$

## **APPENDIX D2 - WATER SUPPLY DISINFECTION PROCEDURE FOR CUT-IN TO EXISTING PIPELINES**

### **1.0 PURPOSE OF THIS PROCEDURE**

Disinfection is a key element in preventing contamination of the water supply. In order to minimise the risk of contamination to the consumers, proper care must be exercised in the shut-down, flushing, repair, and scour of the main.

### **2.0 PRIMARY OBJECTIVE**

To restore water service and prevent contamination of the water supply.

### **3.0 PROCEDURE**

*The use of a disinfectant alone cannot compensate for improper shutdown procedures, inadequate flushing, or the failure of the operator to use good judgment in restoring water service. The proper procedures for main disinfection relate to the overall repair operation, during which the following steps shall be taken:*

1. *Minimise the entry of contaminants into the pipe.*
2. *Remove any contaminants that may have entered the pipe.*
3. *Disinfect any contamination that remains.*
4. *Scour the disinfectant from the pipe.*
5. *Determine the bacterial quality after disinfection.*

#### **3.1 Minimise Entry of Contaminants**

*If the main is shut down and depressurised during repair, contamination is likely, and the main should be thoroughly flushed and disinfected before it is returned to service. The following precautions will minimise contamination of the pipe:*

- (a) *Excavate to provide at least 0.5m of clearance all around the pipe.*
- (b) *Carefully observe the excavation site and look for signs of broken sewer lines.*
- (c) *Keep water pumped out of the trench to prevent dirty water from contacting the pipe.*
- (d) *When the pipe is cut, carefully observe the water that flows out of the pipe. If the water is dirty, the main may have been shut down too soon. Backflush until the water flows clear.*
- (e) *Always examine the inside of the pipe for dirt, pieces of pipe and rocks.*

#### **3.2 Remove Contaminants**

Physically remove contaminants before attempting disinfection. Particulate matter is generally removed by flushing. Always backflush in both directions. The minimum flushing velocity should be 0.75m/s.

If the pipe is cut and a section is removed, always backflush into the trench to remove the pieces of pipe, scale, or anything that may have broken loose or entered the pipe. Provide adequate pumping to keep the water level below the open pipe (it may be necessary to dig a sump). For large diameter mains consider the use of a temporary blank flange on the end with smaller tapping for flushing. Always flush until the water runs clear.

**3.3 Disinfect the Pipe (by the most appropriate of the following methods)****3.3.1 Swabbing (for cut-ins, fittings and valves) — use hypochlorite solution 20 — 50 ppm**

All new pieces of pipe, couplings, clamps, or sleeves are swabbed with a concentrated solution of hypochlorite to disinfect the interior surfaces. Following swabbing, the repair is completed and the main flushed without allowing further contamination of the pipe and fittings. The procedure is:

- (a) Backflush the existing pipe in both directions.
- (b) In a bucket, prepare a concentrated hypochlorite solution (1% available chlorine). Add approximately (152g) of dry calcium hypochlorite (65% available chlorine) to 10.0 l of water to produce a concentrated hypochlorite solution (5% available chlorine).
- (c) Using clean rags dipped in the hypochlorite solution, swab the inside of both ends of the open pipe as far as can be reached. Swab the interior of all new pieces of pipe, couplings, clamps and sleeves that will be used in the repair. Disinfect longer pieces of pipe using a mop.
- (d) Do not place disinfected materials directly on the ground. Use bricks or blocks to support them.
- (e) Wear proper eye and respiratory protection when working with hypochlorite. Wear rubber gloves and protective clothing.
- (f) Following completion of the repair, flush the main to remove high concentrations of hypochlorite and any materials dislodged from the pipe wall during the repair.

**3.3.2 Spraying (for cut-ins, fittings, valves once installed) — use hypochlorite solution 50 ppm**

Apply the hypochlorite solution (using a sprayer instead of cloth rags e.g. a 10 l pressurised water fire extinguisher).

Large mains should be disinfected more thoroughly, by filling the main with heavily chlorinated water.

*Hypochlorite Injection (for laid pipe sections) — target dosage 20 — 50 ppm (to be agreed prior)*

Using a gasoline or electrically powered chemical-feed pump designed for feeding chlorine solutions (hypochlorinator). After sufficient contact time, the main is scoured to remove the heavily chlorinated water.

The following steps are necessary:

- (a) Shut off all service connections prior to attempting disinfection. This will prevent the entry of highly chlorinated water to the consumer's premises.
- (b) In cases where flushing through the consumer's service line is not possible, remove the meter and install a standpipe at the meter connection. Extend the standpipe at least 0.3m above ground to prevent the backflow of dirty water from the meter box during flushing.
- (c) The hypochlorinator may be adapted to pump through a hydrant or meter connection. If there is no such connection close to the supply valve, it may be necessary to tap the main in order to introduce hypochlorite.
- (d) Always flush the main to remove dirty water and air before attempting disinfection.
- (e) Following the flush, adjust the flow to a constant, measured rate. The flow rate and the pipe size (diameter and length) will determine the time required to dispense the hypochlorite solution throughout the pipe.
- (f) The quantity of liquid hypochlorite and the pumping rate depend on the solution concentration, the chlorine dosage desired, the flow (flushing) rate, and the total volume of the pipe to be chlorinated. A sample calculation is provided.
- (g) Hypochlorite is pumped continuously until the desired chlorine residual is distributed throughout the pipe.
- (h) To determine when the hypochlorite solution has reached the end of the repaired main, measure the chlorine residual at the terminal hydrant or scour point.

- (i) Once the residual is detected at all take-offs, shut down the main and allow the heavily chlorinated water to stand in the pipe. For a chlorine dose of 10 ppm, the recommended minimum contact time is 3 hours.
- (j) The chlorine contact time can be reduced by injecting a more concentrated hypochlorite solution but in no case should the contact time be less than 30 minutes. Sample Calculation

To calculate the amount of hypochlorite solution  $a$ , which is required to disinfect one pipe volume  $V$ ;

$$a = \frac{D}{C} \times V$$

Where

$D$  = chlorine dose = 0.01%w/v(100mg/L = 0.01%)

$C$  = hypochlorite solution concentrated = 12.5% (= 125,000 mg/L)

$V$  = pipe volume = diameter  $\frac{d^2}{4} \times \pi \times$  length of pipe  $L$

For a 150mm diameter pipe and isolated length of 200m:

$$V = \frac{(0.150\text{m})^2}{4} \times \pi \times 200\text{m} = 3.534\text{m}^3 \times 1000\text{L} = 3,534\text{L}$$

now amount of hypochlorite solution  $a$

$$a = \frac{100\text{mg/L}}{120,000\text{mg/L}} \times V = \frac{0.01\%}{12.5\%} \times 3,534\text{L} = 2.827\text{L}$$

$\therefore$  Required amount of 12.5% hypochlorite solution for this line = 2.83L of hypochlorite solution

Note : The chlorine residual can be measured at the site by use of a colorimeter (digital read-out of % available chlorine) or a comparator for approximation by colour comparison with pre-calibrated charts.

### 3.4 Scour Disinfectant from Pipe

At the end of the hypochlorite contact period, scour the main until the chlorine residual has been reduced to the level normally present in water supplied to the area. As a general rule, flush until the pipe volume has been replaced at least once. Prior to restoring service, flush each service line to eliminate air and high concentrations of chlorine.

Note : A Resource Consent may be required prior for discharge of the disinfectant solution from the scour point(s) to a receiving water.

### 3.5 Determine Bacteriological Quality

After the residual disinfectant has been removed from the repaired main, collect a sample from at least one point located immediately downstream of the repair. The sample is to be neutralised and sent to an approved laboratory for Faecal Coliform (FC) determination by E.Coli analysis. The requirement is that no FC's are to be present in any sample (and the water supply).

## **APPENDIX E – WATER MAINS IN PRIVATE LAND**

*(NPDC only)*

*Water mains and associated assets shall be located in the road reserve where possible. Where this is not possible (all other options have been exhausted) alternative solutions will be approved at the TA's discretion.*

*In the specific case of water mains located in right of ways within the New Plymouth District:*

- *Separate connections must be provided for each lot with manifolds and meters at the road boundary.*
- *Lots bordering onto the road boundary must be provided with separate connections from the water main in the road with manifolds and meters outside the boundaries of these lots.*
- *Easements must be registered over the water connections in the right of way in favour of the properties they serve.*
- *Jumbo manifold boxes must be used if two or more connections are provided at the road boundary.*
- *Each manifold must be tagged with the relevant lot numbers (and street numbers if known, this must be added later once street numbers have been allocated).*
- *If the developer is concerned about the distance from the proposed dwelling to the manifold in the road then it is recommended that a separate isolation valve be installed for the water supply pipes to that lot closer to the proposed dwelling site. This will enable the householders to shut off their water supply without having to go to the manifold box at the road boundary to do so.*

*If, for site specific reasons (e.g. ensuring adequate pressure at a dwelling), the above can't be achieved then the TA will consider at its sole discretion the installation of a 63 OD main in a right of way and vestment of this in the Council. In this case an Easement in Gross must be provided.*

*If a fire hydrant is required to comply with the NZ Fire Service Firefighting Water Supplies Code of Practice then the Council will own the hydrant and the main up to the hydrant. In this case manifolds may be located in the right of way up to location of the fire hydrant.*



## Infill Development

### Cross Boundary Water Connections

The water connection of a property shall not be provided through another property. Any exception to this prohibition is solely at the Council's discretion.

Where an exception is granted by the Council, easements must be registered over the water connections in favour of the property it serves.

### INFILL DEVELOPMENT

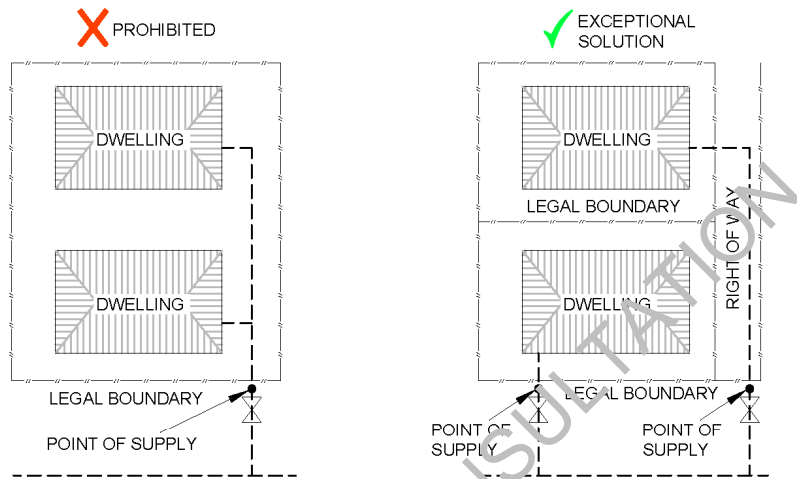

**FUTURE SUBDIVISION**  
 In specific infill circumstances when the preferred solution is not possible. Will only be approved by the T.A. in exceptional cases. Will not be approved in new greenfield subdivision.

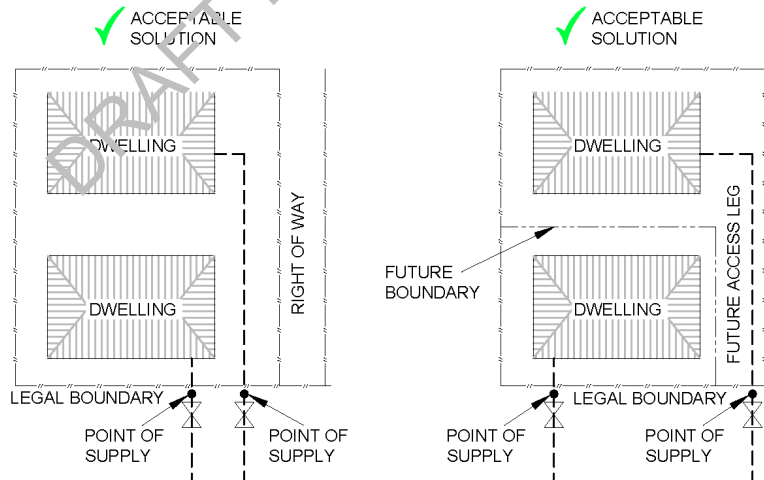

**FUTURE SUBDIVISION**  
 For cross lease units, each unit shall be supplied from a separate service pipe from the council main where additional units are being built.  
 Additional points of supply will be required in such locations as to facilitate later subdivision eg. water supply pipes in future subdivision access